

A Quorum of the Administration Committee, Board of Public Works, Personnel Committee, Plan Commission, Redevelopment Authority, and other City bodies may attend this meeting, though no official action of these bodies will be taken.



COMMON COUNCIL MEETING AGENDA

Monday, January 5, 2026 at 6:00 PM

**First Floor Conference Rooms
100 Main Street, Menasha, WI**

- A. Call to Order**
- B. Pledge of Allegiance**
- C. Moment of Silence - Ana Acosta, Elisha D. Smith Librarian**
- D. Roll Call**
- E. Public Hearing**
- F. Public Comments on Any Matter of Concern to the City**
(5 minute time limit for each person)
- G. Report of Department Officers/Department Heads/Staff/Consultants**
Clerk Snyder - the following minutes and communications have been received and placed on file:
 - 1. Presentations:
 - a. Lenz–Gazecki American Legion Post 152 Donation for the Jefferson Park Pool
 - 2. Minutes to Receive:
 - a. Neenah-Menasha Sewerage Commission, 11/18/25
 - b. Board of Health, 11/5/25
 - c. Administration Committee, 12/15/25
 - d. Board of Public Works, 12/15/25
 - e. Parks & Recreation Board, 12/18/25
 - f. Water and Light Commission, 12/17/25
 - 3. Communications:
 - a. Water Supply Service Area Plan — Menasha Utilities
 - b. Downtown Menasha Parking Time Limit Temporary Suspension Memorandum (12/24/25–01/31/26)
 - c. Urban Forestry Survey
- H. Consent Agenda**
(Prior to voting on the Consent Agenda, items on the Consent Agenda may be

removed at the request of any Alderman and place immediately following action on the Consent Agenda. The procedures to follow for the Consent Agenda are: (a) removal of items from Consent Agenda; and (b) motion to approve the items from Consent Agenda.)

1. Common Council Minutes, 12/15/25
2. Administration Committee, 12/15/25, Recommends Approval of:
 - a. Professional Services Agreement By and Between the City of Menasha and RG Inspections, LLC for 2026 Commercial Electrical Permit Inspection Services, Subject to Autorenewal
 - b. Professional Services Agreement By and Between the City of Menasha and Toole Design Group for Comprehensive Planning Services (Menasha Bike Feasibility Study Project), Not to Exceed \$15,000
3. Parks & Recreation Board, 12/18/25, Recommends Approval of:
 - a. Contract for Services with East Central Wisconsin Regional Planning Commission (ECWPRC) for the Comprehensive Outdoor Recreation Plan Update

I. Items Removed from the Consent Agenda

J. Action Items

1. Transfer Alcohol License Application from El Jaripeo Menasha LLC, DBA El Jaripeo to El Palenque Mexican Gastropub LLC, DBA El Palenque (890 Lake Park Road, Menasha) - "Class B" (Intoxicating Liquor) and Class "B" (Fermented Malt Beverages); Ana Griselda Rivera, Agent
2. Professional Services Agreement(s) between the City of Menasha and MSA Professional Services, Inc. for Design and Construction Management Services - Jefferson Park Aquatic Facility
3. Accounts payable and Payroll for the term of 12/12/25 - 12/31/25 in the amount of \$1,604,970.48

K. Held Over Business

L. Ordinances and Resolutions

1. R-32-25 — A Resolution Increasing Commercial Electrical Permit Inspection Fees, Effective January 6, 2026 (Introduced by Mayor Hammond)
2. O-14-25 — An Ordinance Amending Title 10, Chapter 1, Article C, Sections 10-1-26(7) and 10-1-27(4) of the Code of Ordinances, to Impose a "No Parking" Regulation on Broad Street (Introduced by Ald. Eisenach)
3. O-16-25 — An Ordinance Amending Title 10, Chapter 1, Article C, Sections 10-1-26(49) through 10-1-26(59) of the Code of Ordinances, to Impose a "No Parking" Regulation on Second Street (Introduced by Ald. Ropella)

4. R-2-26 — A Resolution for Participation in the Statewide Public Safety Interoperable Communications System for Winnebago County and the City of Menasha (Introduced by Mayor Hammond)
5. R-1-26 — A Resolution for the Reauthorization of State Funding for the Knowles-Nelson Stewardship Program (Introduced by Ald. Grade and Mayor Hammond)

M. Appointments

1. Mayor's appointment of Tommy Webster to the Parks and Recreation Board for the term of 1/6/26 - 10/1/28

N. Claims Against the City

O. Public Comments on Any Matter Listed on the Agenda
(5 minute time limit for each person)

P. Adjournment

MEETING NOTICE
January 19, 2026
Common Council Meeting – 6:00 PM
Committee Meetings to Follow

"Menasha is committed to its diverse population. Our Non-English speaking population and those with disabilities are invited to contact the Menasha City Clerk at 967-3603 24-hours in advance of the meeting for the City to arrange special accommodations."

NEENAH-MENASHA SEWERAGE COMMISSION

Regular Meeting

Tuesday November 18, 2025

Meeting was called to order by Commission President Mach at 8:00 a.m.

Present: Commissioners Brandon Barlow, Steve Coburn, Corey Gordon, Anthony Mach, Greg Weyenberg, Dale Youngquist; Manager Paul Much; Accounting Clerk Melissa Starr.

Also Present: Scott Becher (Neenah), Troy Beyer (Galloway), Brian Dandoy (McClone), Rob Franck (MCO), Gerry Kaiser (Neenah), Tony Kappell (McMahon), Heath Kummerow (Neenah), Dawn Merlin (McMahon), Chad Olsen (McMahon), Chad Pelishek (Harrison), Vicky Rasmussen (Neenah), Jeremy Searl (Fox Crossing), Alissa Van Eperen (Harrison)

Excused: Commissioner Raymond Zielinski

Minutes

Meeting minutes. A motion was made/seconded by Commissioners Youngquist/Weyenberg to approve the minutes from the October 28, 2025, Regular Meeting. Motion carried unanimously.

NMSC 2026 Property & Liability Insurance Renewal

Brian Dandoy of McClone presented the insurance renewal quote from the League of Wisconsin Municipalities. He reported the overall premium increased \$3,313, and he explained that next year's property premium will have a larger increase due to the appraisal that was recently completed. Total building value went up roughly 12%. After discussion, a motion was made/seconded by Commissioners Weyenberg/Coburn to approve the insurance renewal with the League of Wisconsin Municipalities. Motion carried unanimously.

Correspondence

The following correspondence was discussed:

- November 13, 2025, email from Troy Beyer, Galloway Company to Paul Much, Plant Manager
RE: Galloway Update

Old Business

There was no old business to be discussed.

New Business

Operations, Engineering, Planning

Update on Galloway's efforts to achieve compliance with pretreatment limits: Troy Beyer gave an update on Galloway Company's progress and shared that they have partnered with a chemical provider and equipment manufacturer and expanded their sampling plan to get more data. He shared that more time is needed to get the data to determine future loadings. Commissioners were willing to give more time to collect data and Troy said he should have an update by the end of December.

Financing Options for Plant Upgrade: Brad Viegut of Baird presented eight financing scenarios based on discussions with Commissioners. Scenarios 1-4 include UV disinfection, while scenarios 5-8 do not. Each table gives a comparison of the use of revenue bonds pledged by the Commission, versus Clean Water Fund Loans that each community must apply to borrow. Discussion followed regarding the pros and cons of each option as well as the possibility of water trading. Engineer Olsen stated that the commissioners will need to know which direction their community wants to go in by the next meeting.

Commissioners agreed to discuss the options with their municipal leadership and email Manager Much the direction their community wants to go.

McMahon Associates Report: Engineer Olsen shared the opinion of probable cost for the two NMSC project options; (1) Cloth Disk Filters, UV Disinfection, & Flow Meter (\$35,000,000), or Cloth Disk Filters & Flow Meter (\$24,000,000). He also provided schematics and layouts of the two options for commissioners to review.

McMahon Invoices: A motion was made/seconded by Commissioners Coburn/Weyenberg to approve payment of invoice #941071, Facilities Plan Amendment, in the amount of \$11,550.00. Motion carried unanimously.

Operating Report: Manager Much reported no issues with operations this month. He followed up by letting commissioners know that plant staff are still working to determine the source of the elevated mercury and metals.

Equipment & Grounds Report: Rob Franck reviewed his report and provided further details on: Screw pump #4 upper and lower bearing assemblies were replaced by Crane Engineering and is back in service. The RAS room painting will begin the last week of November. The hot water loop replacement between the Plant Drain and Digester buildings had temporary lines removed, and the larger piping was televised to ensure they could be used for routing the permanent piping. The concrete pad for this work will be completed in the spring of next year. Winterizing of equipment is currently in process.

Budget, Finance, Personnel

Financial Statements: Accounting Clerk Starr reported an operating income for the month of October and MCO generated about \$7,161.13 in additional revenue for the Commission. She reported that operations continue to project lower than last year, so the O&M rates for the December billings were also reduced by 50%.

TruGreen Lawn Service Renewal: Rob Franck reported that TruGreen had sent the corrected service renewal form for 2026, and it includes the four "TruYou Lawn Services" only, as discussed at the last meeting. After discussion, a motion was made/seconded by Commissioners Weyenberg/Coburn to approve the TruGreen Lawn Service renewal for \$3,862.84. Motion carried unanimously.

Update on Sonoco Contract Renewal: Manager Much shared the contract extension that was prepared for Sonoco/U.S. Paper to extend the agreement term until August 31, 2026, at which time a new contract will be negotiated utilizing current data. After discussion, a motion was made/seconded by Commissioners Coburn/Weyenberg to approve the contract extension. Motion carried unanimously.

MCO Invoices: A motion was made/seconded by Commissioners Coburn/Weyenberg to approve for payment MCO invoices #32282 in the amount of \$151,757.34, and #32335 in the amount of \$506.80, with payment to be made after December 1, 2025. Motion carried unanimously.

Vouchers: A motion was made/seconded by Commissioners Coburn/Gordon to approve Operating and Payroll Vouchers #141306 through #141363 in the amount of \$401,537.49 for the month of October 2025. Motion carried unanimously.

Adjournment

A motion was made/seconded by Commissioners Coburn/Weyenberg to adjourn the meeting. Motion carried unanimously. Meeting adjourned at 8:53 a.m.

President

Secretary

CITY OF MENASHA BOARD OF HEALTH
Minutes
November 5, 2025

A. CALL TO ORDER

Meeting called to order by Candyce Rusin at 8:41 AM

B. ROLL CALL/EXCUSED ABSENCES

PRESENT: Gary Daughtery, Kristine Hutter, Candyce Rusin, Kristene Stacker

ABSENT: Dr. Andrew Dunn

ALSO PRESENT: EHS Todd Drew, PHE Claire Holzschuh, OC Larissa Keller, PHN Meghan Pauly

GUEST: WI DHS DPH Office of Policy and Practice Alignment Northeast Region Director Chris Culotta

C. MINUTES TO APPROVE

1. Board of Health, October 1, 2025

Moved by Kristene Stacker and seconded by Candyce Rusin to approve the October 1, 2025 minutes. The motion carried.

2. Special Board of Health, October 22, 2025

Moved by Candyce Rusin and seconded by Gary Daughtery to approve the October 22, 2025 minutes. The motion carried.

D. PRESENTATION

1. WI DHS DPH Office of Policy and Practice Alignment Northeast Region Director Chris Culotta – Presentation of DHS 140 Certificate for Menasha Health Department

Director Culotta presented the DHS 140 Certificate for Menasha Health Department. The DHS 140 review is performed every five years as an audit for minimum compliance with WI state statute. Public health departments are granted a designation of Level 1, Level 2, or Level 3. Following the audit of Menasha Health Department on April 9, 2025, the review concluded that a designation of Level 3 (highest level) was appropriate. Director Culotta shared some positives from the review, as well as some considerations and opportunities for improvement including increased advocacy of public health prevention strategies in conjunction with departmental and City-wide comprehensive planning.

E. REPORT OF DEPT HEADS/STAFF/CONSULTANTS

1. Administrative

a. 2026 Annual Budget

PHD Hutter stated that the proposed budget for 2026 is posted on the Finance page of the city website and has been delivered to Common Council for consideration. All of the health department budgets are viewable within the proposed budget document and are similar to past years. The main health department budget covers staff wages and benefits, operations and supplies, and language services. PHD Hutter will present the health department budgets to the Common Council on November 12th.

2. Employee Safety

EHS Drew reported that a representative from CVMIC conducted training for bloodborne pathogen, hearing conservation and fire extinguishers at Public Works in October. He has revised the emergency plan for City Hall, Public Works, Senior Center, and the library. All employees in the Menasha City Center building, including MJSD and City, will use a messaging app to notify

building staff of any emergency situations. EHS Drew trained one new City employee and the new commercial building inspector. He conducted safety oversight and hazard assessment for the Project Front Porch event on October 9th.

3. Sealer of Weights and Measures

EHS Drew reported that he picked up the gas pump testing equipment from De Pere and will begin testing gas pumps, weather permitting.

4. Environmental Health

EHS Drew reported that he is conducting routine inspections, and three pre-inspections for change of operator were completed. All public and parochial school inspections are complete. He has investigated 5 human health hazard complaints, completed 4 DNR inspections, and issued 3 enforcement actions. EHS Drew has followed up on 6 animal bites, 1 of which resulted in a rabies prophylaxis recommendation. DHS and DNR are working on vapor intrusion testing of three homes. Waste at the former Whiting Paper site has been classified and readied for removal. EHS Drew attended the WALHDAB EH meeting on October 16th. There is a new motel/hotel/tourist rooming house code and updated fee schedule change coming in the near future.

5. Public Health Department

a. Communicable Disease Reports: October 2025

The Communicable Disease report for October 2025 was shared by PHD Hutter.

b. UWO Students

PHD Hutter reported that the UW-Oshkosh nursing students assisted at the community flu clinic and continue to shadow our staff. They are currently working on their aggregate project.

6. Immunization

a. 2025-2026 Contract Objective/Activities

PHD Hutter reported that the current immunization contract has been aligned to match the state fiscal year, July 1, 2025, to June 30, 2026, and new contract objectives, activities, and budget have been submitted for this period. PHN Pauly stated that the contract objective has been changed to focus on increasing rates of MMR and Varicella vaccination in children in Menasha. PHN Pauly will be conducting activities to target children entering kindergarten and new enrollments as these populations typically have lower rates of these two vaccines. Monthly VFC clinics continue to be held. A change in VFA program funding will leave us with approximately one third of the amount of vaccine we can offer to uninsured and underinsured adults.

7. Health Screening 60+

PHN Pauly reported that the massage therapist will be back to the Senior Center for chair massages in December. Memory Café will feature a speaker series for 2026.

8. Dental Program

PHD Hutter reported on behalf of RDH Opsteen. RDH Opsteen is currently doing dental presentations at the schools and has started the first fluoride applications.

9. Prevention

PHD Hutter reported that end of year reporting has been completed for the 2025 contract year and a new contract has been negotiated and signed for 2026. 2026 funds will be used for

performance management development and supporting activities for youth mental health promotion (MCH).

10. Maternal and Child Health

a. 2026 Contract Objective/Activities

PHD Hutter reported that we will be working on the same objective, adolescent mental health, for contract year 2026. PHE Holzschuh is working with Library Director Brian Kopetsky to put develop social emotional learning opportunities that can be completed at, or checked out from, the library. The Salvation Army Childcare Center has completed their breastfeeding friendly designation. Although we will no longer actively recruit area businesses for the breastfeeding friendly designation, we will continue to assist with redesignation efforts if needed.

F. DISCUSSION/ACTION ITEMS

1. December Board of Health Meeting

The Board discussed possible cancelation or rescheduling of the December meeting due to PHD Hutter's upcoming vacation. The decision was made to reschedule from December 3rd at 8:30 AM to December 10th at 9:00 AM.

G. ADJOURNMENT

Moved by Kristene Stacker and seconded by Gary Daughtery to adjourn the meeting at 9:44 AM. The motion carried.

Next Meeting: December 10, 2025 9:00 AM – Microsoft Teams

Menasha City Center
100 Main Street, Suite 100
Menasha, WI



ADMINISTRATION COMMITTEE MINUTES

Monday, December 15, 2025 at 6:30 PM

First Floor Conference Rooms
100 Main Street, Menasha, WI

A. CALL TO ORDER

Meeting called to order by Chair Eisenach at 6:50pm.

B. ROLL CALL

Present: Aids. Rand, Eisenach, Hale, Lewis, Marshall, Grade, Ropella

Absent: Ald. Perkins

Also Present: FD Sassman, DPW Merten, CDD Dane, PRD Sackett, PC Thorn, CA Struve, Mayor Hammond, Clerk Snyder

C. MINUTES TO APPROVE

1. Administration Committee, 12/1/25

Motion by District 3 Alderperson Hale seconded by District 7 Alderperson Grade to approve. Motion carried on voice vote.

D. DISCUSSION / ACTION ITEMS

1. Professional Services Agreement By and Between the City of Menasha and RG Inspections, LLC for 2026 Commercial Electrical Permit Inspection Services, Subject to Autorenewal

Motion by District 3 Alderperson Hale, seconded by District 6 Alderperson Marshall to approve.

Motion carried 7-0 on roll call.

Staff advised on RG Inspections, LLC and the firm's required minimum fee for related electrical inspections.

2. R-32-25 – A Resolution Increasing Commercial Electrical Permit Inspection Fees, Effective January 6, 2026 (Introduced by Mayor Hammond)

Motion by District 3 Alderperson Hale, seconded by District 5 Alderperson Lewis to approve.

Motion carried 7-0 on roll call.

3. Professional Services Agreement By and Between the City of Menasha and Toole Design Group for Comprehensive Planning Services (Menasha Bike Feasibility Study Project), Not to Exceed \$15,000

Motion by District 3 Alderperson Hale, seconded by District 6 Alderperson Marshall to approve.

Motion carried 7-0 on roll call.

Staff advised that the purpose of the proposed PSA with Toole Design Group is to assist with the transportation chapter update in Menasha's Comprehensive Plan.

E. ADJOURNMENT

Motion by District 3 Alderperson Hale seconded by District 7 Alderperson Grade to adjourn the Administration Committee meeting at 6:57pm. Motion carried on voice vote.

Minutes submitted by City Clerk Kaija Snyder.



BOARD OF PUBLIC WORKS MINUTES
Monday, December 15, 2025 at 6:45 PM
First Floor Conference Rooms
100 Main Street, Menasha, WI

A. CALL TO ORDER

Meeting called to order by Chair Ropella at 7:03pm.

B. ROLL CALL

Present: Aids. Rand, Eisenach, Hale, Perkins, Marshall, Grade, Ropella

Absent: Ald. Perkins

Also Present: FD Sassman, DPW Merten, CDD Dane, PRD Sackett, PC Thorn, CA Struve, Mayor Hammond, Clerk Snyder

C. PUBLIC COMMENTS ON ANY MATTER LISTED ON THE AGENDA

Kirsti Ritschki (511 Broad Street, Menasha) commented on the proposed ordinance imposing a "no parking" regulation on Broad Street. Ritschki specifically described that her home's driveway apron orientation is blocked by vehicles parked on the street, and that the proposed ordinance would enhance safety for herself and other residents living in the 511 Broad Street units. Ritschki also expressed concerns for pedestrians in these blindspots. Ritschki thanked the Common Council for considering the initiative.

Mike Quinn (937 Fourth Street, Menasha) commented on the proposed ordinance imposing a "no parking" regulation on Fourth Street. Quinn described that because the ordinance imposes parking regulations on only one side of the street, the opposite side will be disproportionately affected by residents who park on the street out of preference, and without conferring with neighbors. Quinn further described that Fourth Street experiences overflow parking during Jefferson Park events. Quinn advocated that the Common Council vote against this initiative.

Patricia Griesbach (928 Fourth Street, Menasha) commented on the proposed ordinance imposing a "no parking" regulation on Fourth Street. Griesbach described that many homes on Fourth Street have narrow driveways, resulting in many residents leaving a vehicle in the street to allow a second vehicle access; the proposed ordinance limits this parking. Griesbach additionally commented on speeding on Fourth Street, and suggested this began when Fourth Street became a thru street.

Jamie Vandenberg (913 Fourth Street, Menasha) commented on the proposed ordinance imposing a "no parking" regulation on Fourth Street. Vandenberg specifically commented on concerns around garbage and refuse collection efficacy due to increased parking on one side of Fourth Street, speeding, and the nearby Public Works Facility.

George Davis (511 Broad Street, Menasha) commented on the proposed ordinance imposing a "no parking" regulation on Broad Street. Davis described himself as in favor of safe parking, but suggested that removal of the extant 15-minute parking is arbitrary. Davis additionally commented on different vehicle sizes, different volumes of traffic, and traffic signals.

KristL Laux (388 Naussau Street, Menasha) commented on the proposed ordinance imposing a "no parking" regulation on Second Street. Laux questioned how often the affected Clinton Center Park is used, and where park visitors can park if not on Second Street.

Jeff Harvey (514 Broad Street, Menasha) commented on the proposed ordinance imposing a "no parking" regulation on Broad Street. Harvey described a lack of traffic incidents requiring Municipal Code updates. Harvey suggested that limited parking in this area will result in street parking near his property. Instead, Harvey suggested improved snow plowing to heighten visibility for the units located at 511 Broad Street, or limited parking restrictions in front of this property. Harvey also discussed installing speed bumps to prevent speeding on residential streets.

D. MINUTES TO APPROVE

1. Board of Public Works, 12/1/25
Motion by District 8 Alderperson Ropella seconded by District 6 Alderperson Marshall to approve. Motion carried on voice vote.

E. DISCUSSION / ACTION ITEMS

1. O-14-25 — An Ordinance Amending Title 10, Chapter 1, Article C, Sections 10-1-26(7) and 10-1-27(4) of the Code of Ordinances, to Impose a "No Parking" Regulation on Broad Street (Introduced by Ald. Eisenach)
Motion by District 2 Alderperson Eisenach, seconded by District 1 Alderperson Rand to approve the main motion as amended.

Motion carried 7-0 on roll call.

Motion by District 2 Alderperson Eisenach, seconded by District 6 Alderperson Marshall to amend the main motion by adding removal of the 15-minute parking on North Broad Street.

Motion carried 7-0 on roll call.

Discussion considered how near to an intersection parking is permitted and specific segments of Broad Street affected by the proposed ordinance.

Staff advised that the purpose of this ordinance is to control traffic volume due to visibility constraints and unique residential-commercial zoning immediately.

Staff additionally advised on one submission from a resident at 511 Broad Street who expressed opposition to the proposed "no parking" ordinance on Broad Street.

2. O-15-25 — An Ordinance Amending Title 10, Chapter 1, Article C, Section 10-1-26(16) of the Code of Ordinances, to Impose a “No Parking” Regulation on Fourth Street (Introduced by Ald. Marshall)
Motion by District 6 Alderperson Marshall, seconded by District 5 Alderperson Lewis to approve.

Motion failed 0-7 on roll call.

Discussion considered the width of Fourth Street, neighborhood relations, and the origins of this ordinance proposal.

Staff advised on submissions from residents at 912 Fourth Street and 900 Fourth Street who opposed the proposed "no parking" ordinance. Staff additionally described that national standards typically do not lend themselves to parking restrictions on residential streets of similar densities. Staff has recommended denial of the presented ordinance.

3. O-16-25 — An Ordinance Amending Title 10, Chapter 1, Article C, Sections 10-1-26(49) through 10-1-26(59) of the Code of Ordinances, to Impose a “No Parking” Regulation on Second Street (Introduced by Ald. Ropella)
Motion by District 8 Alderperson Ropella, seconded by District 6 Alderperson Marshall to approve.

Motion carried 7-0 on roll call.

Staff advised that this ordinance proposal originated from a request by Essity Professional Hygiene North America LLC, and is balanced against a need to maintain adequate parking for Clinton Center Park users.

F. ADJOURNMENT

Motion by District 6 Alderperson Marshall seconded by District 5 Alderperson Lewis to adjourn the Board of Public Works meeting at 8:04pm. Motion carried on voice vote.

Minutes submitted by City Clerk Kaija Snyder.

CITY OF MENASHA
Parks and Recreation Board
City Center (100 Main St., Menasha)
December 18, 2025
MINUTES

A. CALL TO ORDER

The meeting was called to order by Chr. Dick Sturm at 5:32pm.

B. ROLL CALL/EXCUSED ABSENCES

MEMBERS PRESENT: Chr. Dick Sturm, Vice Chr. Brian Adesso, Ald. Ted Grade, Melissa Grade, and Danielle Rand

OTHERS PRESENT: PRD Megan Sackett, City Arborist Dylan Wenker, Tim Murphy and Colton Dunke from MurphComp

EXCUSED ABSENCE: Eli Wickman

C. PUBLIC COMMENT/CORRESPONDENCE

T. Murphy and C. Dumke expressed the continued excitement regarding the possible reconstruction of the Hart Park Skatepark and requested an update from the Board regarding the proposal for the updated Hart Park Skatepark. Director Sackett noted she emailed another representative from the MurphComp group with an update and noted that the City has placed funding in the 5-year CIP plan to assist with design and construction. Sturm noted that this topic could be placed on a future agenda to review the proposal. Sackett noted she will contact the MurphComp group to let them know when it will be placed on the agenda.

D. MINUTES TO APPROVE

1. **Minutes of the November 11, 2025 Regular Park Board Meeting:** Motion by T. Grade, seconded by B. Adesso to approve the minutes of the November 11, 2025 Regular Park Board meeting. Motion carried.

E. DISCUSSION / ACTION ITEMS

1. **Jefferson Park Tree Planting Plan:** City Arborist Dylan Wenker gave an overview of the proposed tree planting plan for Jefferson Park noting 63 trees are scheduled to be planted in 2026. Wenker emphasized the plan focuses on diversity in tree species and planting in locations where trees were removed for construction, replacement of dying ash trees and gaps in canopy while still recognizing the need to maintain open play spaces and community gathering spaces.

Discussion from the Board focused on the removal of the large Willow Tree on Peanut Island and maintaining an open view from the social space.

Sackett noted that it is atypical to bring a planting plan to the Board; however, staff felt that, given the scope, visibility and significance of the Jefferson Park project, Board review was appropriate.

Motion made by T. Grade, seconded by M. Grade to approve the Jefferson Park Planting plan as presented. Motion carried.

2. **Jefferson Park Landing Pavilion Sign:** Dir. Sackett reviewed the proposed Jefferson Landing Pavilion sign noting that it follows the same design as the Menasha Corp Pavilion sign. Sackett noted the City logo was added since the Menasha Corp Pavilion sign has their business logo and helped to balance the design of the sign. Sackett also noted there are two price estimates due to varying sizes.

Motion made by M. Grade, seconded by D. Rand for the approval of the sign for the Jefferson Landing Pavilion as presented with Megan deciding on size. Motion carried.

3. **Contract for Services with East Central Wisconsin Regional Planning Commission (ECWEPC) for the Comprehensive Outdoor Recreation Plan (CORP) Update:** Dir. Sackett noted the current CORP was adopted in 2020 and it is vital to ensure it reflects current goals and priorities and community needs and is also required for grant eligibility. Sackett noted this update will allow the City to reassess priorities, update data and mapping and ensure alignment with other planning efforts within the City. Sackett also noted the Park Board and community will have an opportunity for involvement and feedback during the process.

Motion made by T. Grade, seconded by M. Grade to recommend approval to the Common Council for the Contract for Services with East Central Wisconsin Regional Planning Commission (ECWRPC) for the Comprehensive Outdoor Recreation Plan (CORP) Update. Motion carried.

4. **R-1-26 Reauthorization of State Funding for the Knowles-Nelson Stewardship Program:** Sackett indicated the Knowles-Nelson Stewardship program began in 1989. Menasha has received over \$2M in funding since that time. Sackett noted this funding is critical for many municipal Park and Recreation Departments to leverage local dollars and complete park improvements, trail development, land conservation and public access projects. Sackett also noted funding was removed from the recent Governor's budget and is set to expire in June 2026. Sackett noted resolutions will also be sent to our State Legislators by other municipalities and government agencies around the state to encourage continued investment into this program.

Motion made by T. Grade, seconded by M. Grade to recommend to Common Council the approval of R-1-26 for the Reauthorization of State Funding for the Knowles-Nelson Stewardship Program. Motion carried.

F. REPORT OF DEPARTMENT HEAD / STAFF

1. **Department Report:** See attached written report.

G. PUBLIC COMMENT ON ANY MATTER LISTED ON THE AGENDA

None

H. ADJOURNMENT

Motion by B. Adesso, seconded by M. Grade to adjourn at 7:10 pm. Motion carried.

PARK BOARD REGULAR MEETING NOTICE
Thursday, January 13, 2025
City Hall (100 Main St., Rm 133) – 5:30 pm

REGULAR MEETING OF THE WATER AND LIGHT COMMISSION

December 17, 2025

Draft

Commission President Allwardt called the Regular Meeting of the Water and Light Commission to order at 8:00 a.m., with Commissioners Roy Kordus (telephonically), and Austin Hammond, present on roll call. Also present were Melanie Krause, General Manager; Kristin Hubertus, Finance Manager; Kurt Melchert, Electric Manager; Adam Smith, Water Plant Manager; Paula Maurer, Customer Service Manager; Justin Hoffmann, Project Engineer; and Tammy Phillips, Accounting and Administrative Assistant. Also present was Colten Sprenger, WPPI Energy Services Manager.

Those excused were: Antoine Tines, Gary Turchan, and Steve Grenell

Item II. No one from the Gallery requested to be heard on any topic of public concern to the Utility.

Item III. Motion made by Comm. Allwardt, seconded by Comm. Kordus, was unanimous on roll call to approve the following:

- A. Minutes of the Regular Meeting of November 19, 2025.
- B. Approve and warrant the following payments dated November 20 – December 17, 2025 in the amount of \$3,801,991.23.
- C. Correspondence as listed:
 - Copy of Letter from Habitat for Humanity RE: Menasha Homes Donation
 - Copy of News Release RE: Agreement Between NextEra Resources and WPPI to Serve the Upper Midwest with Nuclear Energy
 - Copy of PSC Utility Customer Bill of Rights
 - Copy of December MU Customer Promos
 - Copy of 2025 Business Customer Satisfaction Study Results
 - Copy of MU November Newsletter

Item IV. Claims Against the Utility – There were no claims discussed at this meeting.

Item V. Purchase Orders over \$25,000.00 issued since the last Commission meeting were presented for informational purposes.

Item VI. Unfinished Business. There was no unfinished business discussed at this meeting.

Item VII. New Business, Electric Distribution Presentation. MU Linemen presented a powerpoint highlighting major jobs completed for 2025.

2025 Customer Service Program Recap. Paula Maurer presented a summary of 120 ways the Utility gave back to the community in 2025.

2026 Chemical Consortium Pricing. A breakdown of 2026 chemical costs was discussed.

Water Service Area Plan. Adam Smith presented a powerpoint of the Utility Water Service Area Plan according to DNR requirements. The Plan has been added to the website and is open for public comment.

A Resolution of Appreciation for Rob Ujazdowski and his 23 years of service to MU was presented.

The motion by Comm. Allwardt, seconded by Comm. Hammond, was unanimously approved on roll call to accept the Resolution of Appreciation for Rob Ujazdowski.

Employee Handbook and Base Pay Rate changes and updates for 2026 were discussed.

The motion by Comm. Allwardt, seconded by Comm. Hammond, was unanimously approved on roll call to accept the Employee Handbook and Base Pay Rate changes and updates.

Item VIII. Strategic Reports, Monthly Strategic Initiative Update – The November report was discussed.

November Financial and Project Status Reports – Electric consumption was under budget by 11.3% for the month, cost of power was 3.9% lower, and Net Operating Income was lower by \$360,405, due to lower consumption and revenues.

Water usage was lower than budget by 15.5%, there is a negative system loss ratio due to a recalibration of the High Lift Pump Station meter and a large hole and break by an apartment complex, and Net Operating Income was higher by \$470 for the month.

After discussion, the Commission accepted the November Financial and Project Status Reports as presented.

Project Reports, Electric Projects – Crews worked on the underground project off Midway Rd, new services, building maintenance, and assisted the operations crew with cable testing at the substations.

Water Projects – Staff worked on the catwalk in the basin, AMI meter exchanges, a new main switch at the Water Plant, LSL replacements, and work continues on the Water Plant Network Segregation Project.

Item IX. No one from the Gallery requested to be heard on any topic of public concern to the Utility.

Item X. ADJOURN

By: MARK L. ALLWARDT
President

GARY TURCHAN
Secretary

NOTE: THESE MINUTES ARE NOT TO BE CONSIDERED OFFICIAL UNTIL ACTED UPON AT THE NEXT REGULAR MEETING, THEREFORE, ARE SUBJECT TO REVISION.



2025

WATER SUPPLY SERVICE AREA PLAN

TABLE OF CONTENTS FOR NR 854

1) NR 854.04

- 1.1 Requirements
- 1.2 Review period

2) NR 854.05

- 2.1 Planning period
- 2.2 Planning area
- 2.3 Description of public water supply
- 2.4 Existing sources and withdrawals
- 2.5 Existing water use
- 2.6 Projected water demand
- 2.7 Inventory and identification of sources and quantities
- 2.8 Plan recommendations
- 2.9 Analysis of consistency with other plans

3) NR 854.08

- 3.1 Public participation
- 3.2 Submission of plan to local governments
- 3.3 Public inspection

NR 854.04

1.1 Requirements

Menasha Utilities (MU) owns or operates a public water supply that serves a non-transient population of 15,144 people and withdraws water from the waters of the state. Menasha Utilities is required to prepare a Water Supply Service Area Plan (WSSAP) on or before December 31st, 2025.

1.2 Review period

This plan is a dynamic document and will be updated if demographics or water consumption changes more than projections forecasted. At a minimum the plan will be reviewed every 5 years and updated as needed. A new plan will be prepared on or before the expiration date of this plan. The Wisconsin Public Service Commission annual report data will be monitored for changes.

NR 854.05

2.1 Planning period

The established planning period starts January 1st, 2026, and expires at the conclusion of December 31st, 2045. A WSSAP is required to have a planning period of at least 10 years and no more than 20 years.

2.2 Planning area

Menasha Utilities does not serve the entire City of Menasha and is surrounded by neighboring public water suppliers. Menasha Utilities shares water district borders with the City of Neenah on the south side and the Village of Fox Crossing on the north and northeast side of the planning area. Little Lake Butte Des Morts spans the entire west border, and Lake Winnebago covers the southeast perimeter. The Fox River flows from east to west through the southern portion of Menasha Utilities' water district. The entire planning area is confined within Winnebago county. This plan does not include projected growth areas because all land surrounding Menasha Utilities' borders is appropriated.

MENASHA UTILITIES WATER SERVICE AREA

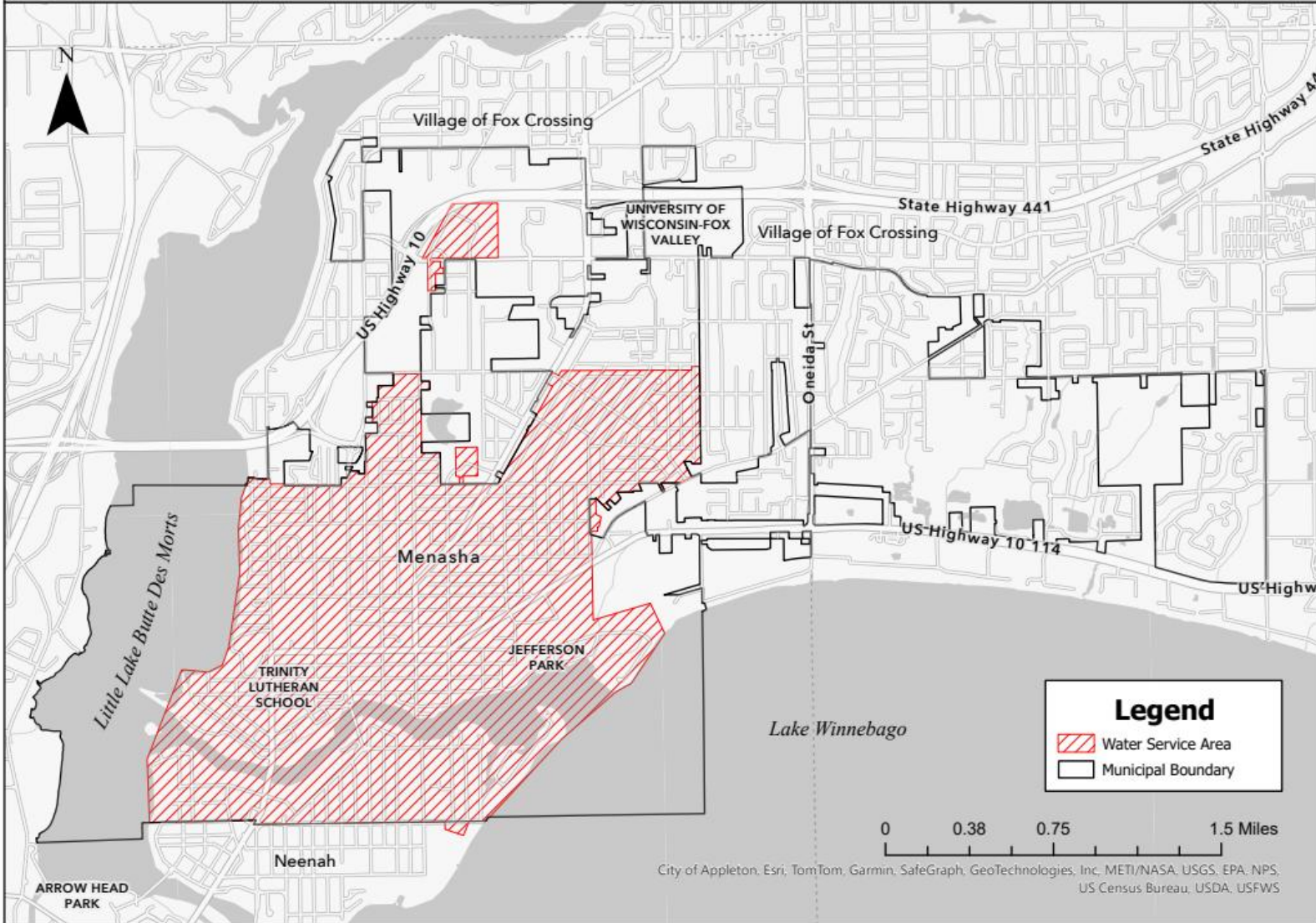

2.3 Description of public water supply

Surface water: Menasha Utilities utilizes Lake Winnebago as its source. Lake Winnebago has a surface area of nearly 138,000 acres. Lake Winnebago is the largest lake in the state of Wisconsin. Its maximum depth is only 21 feet with an average depth of 15.5 feet. The lake has a calculated volume of 696 billion gallons. It has a length of about 28 miles and a width of about 10 miles. Lake Winnebago normally experiences ice cover from late December to April. These physical characteristics coupled with resuspension of sediment by wind and high nutrient loading associated with land activities throughout the watershed combine to make Lake Winnebago a warm nutrient rich lake with poor water quality. Wind plays a major role in the water quality of Lake Winnebago. Wind frequently suspends sediment in the lake water. Locally, this churns and redistributes contaminants that would normally remain on the lake bottom. The extent of lake conditions and mixing caused by wind is not fully understood.

Water Quality: Existing monitoring data indicates Menasha's source water is highly turbid with poor water quality for microbial, organic, and inorganic parameters. Generally, water quality is highest during late winter. This is due to less runoff from the source water area and ice cover preventing resuspension of sediment. Water quality is lowest during late summer and early fall when windstorms of varying direction resuspend sediment, water temperatures rise, and more nutrient loading from the watershed. Daily fluctuations in water quality occur because of wind. Periods of southerly winds often coincide with poor source water quality. Spring runoff from snow melt strongly affects water quality in Lake Winnebago. Source water quality is determined from compliance and operational sampling that is required at drinking water intakes.

Source water monitoring for microbial containments has revealed high levels of total coliform and fecal coliform at the intake. Lake Winnebago is known for large algal blooms, especially blue-green algae.

Intake Channel: Source water flows from the north end of Lake Winnebago into an intake channel that branches off the mouth of the Fox River. The intake channel is equipped with a channel circulation pump that helps remove debris and floating algae that accumulates in the channel. The water from the channel pump is discharged back into Lake Winnebago. The pump capacity is 10 MGD and is designed to run from April through November. If debris plugs the pump suction, it will shut off to protect the pump motor. Logs are in place to prevent floating debris from reaching the pump suction. At the end of the intake channel, water flows over a weir and through a set of intake screens before it enters the pretreatment basin.

The screens are stationed at a building called the “Head House” that precedes the pretreatment basin.

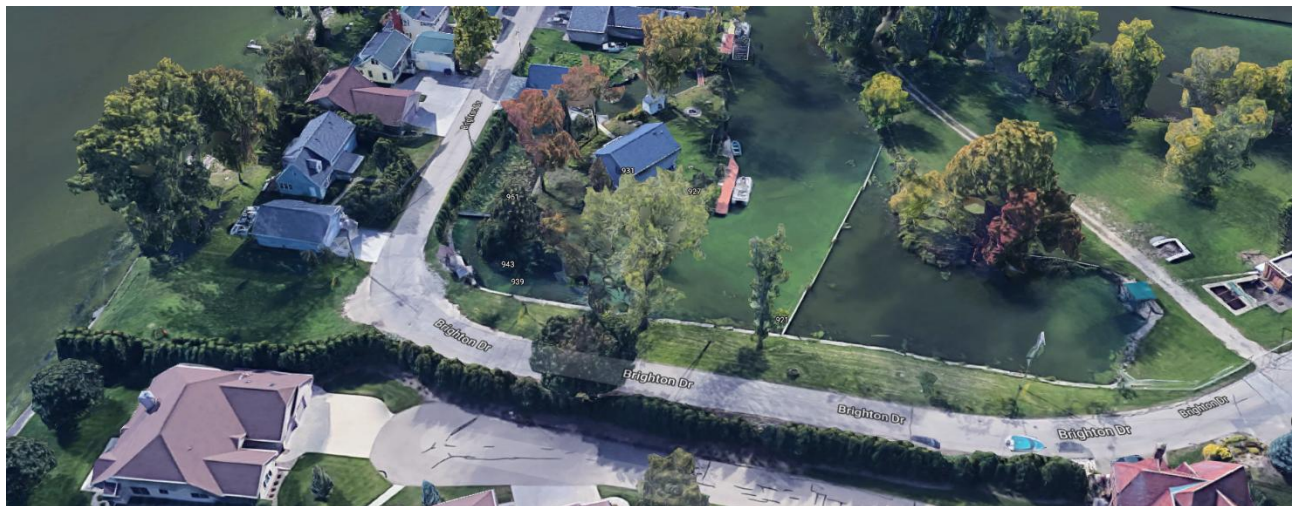
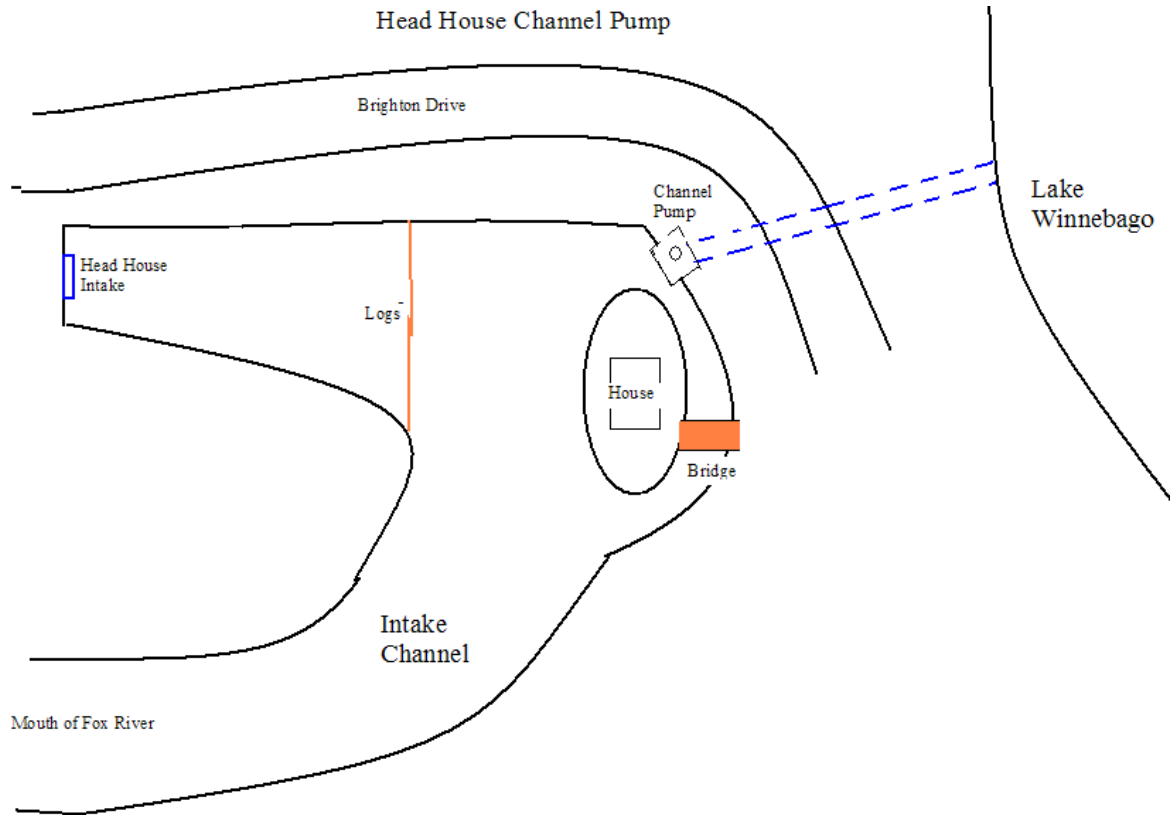

Head House Pretreatment Basin: The head house is located at the west end of Jefferson Park. It is a detention basin that holds 4 to 8 days of water. Screens remove large debris both before the water enters the basin and before water leaves the basin.

Potassium permanganate is fed prior to the intake of the basin. An adjustable weir controls the flow entering the head house basin. Dosage is dependent on water quality and temperature. Potassium permanganate is used for taste and odor control, algaecide, and zebra mussel control. Potassium permanganate is not fed during winter months because raw water quality is much better and zebra mussels are inactive in cold water. The basin has a series of baffles to direct flow and limit short circuiting. Water leaves the basin through a 42" concrete pipe that travels under the chemical feed building. Potassium permanganate is fed a second time at the chemical feed building to oxidize any potassium permanganate ($KMnO_4$) to manganese dioxide (MnO_2) which is an insoluble precipitate that can be removed during the sedimentation and filtration processes. The 42" concrete pipe takes water to the Water Plant's low lift wetwell. There is a third set of screens prior to the low lift wetwell.

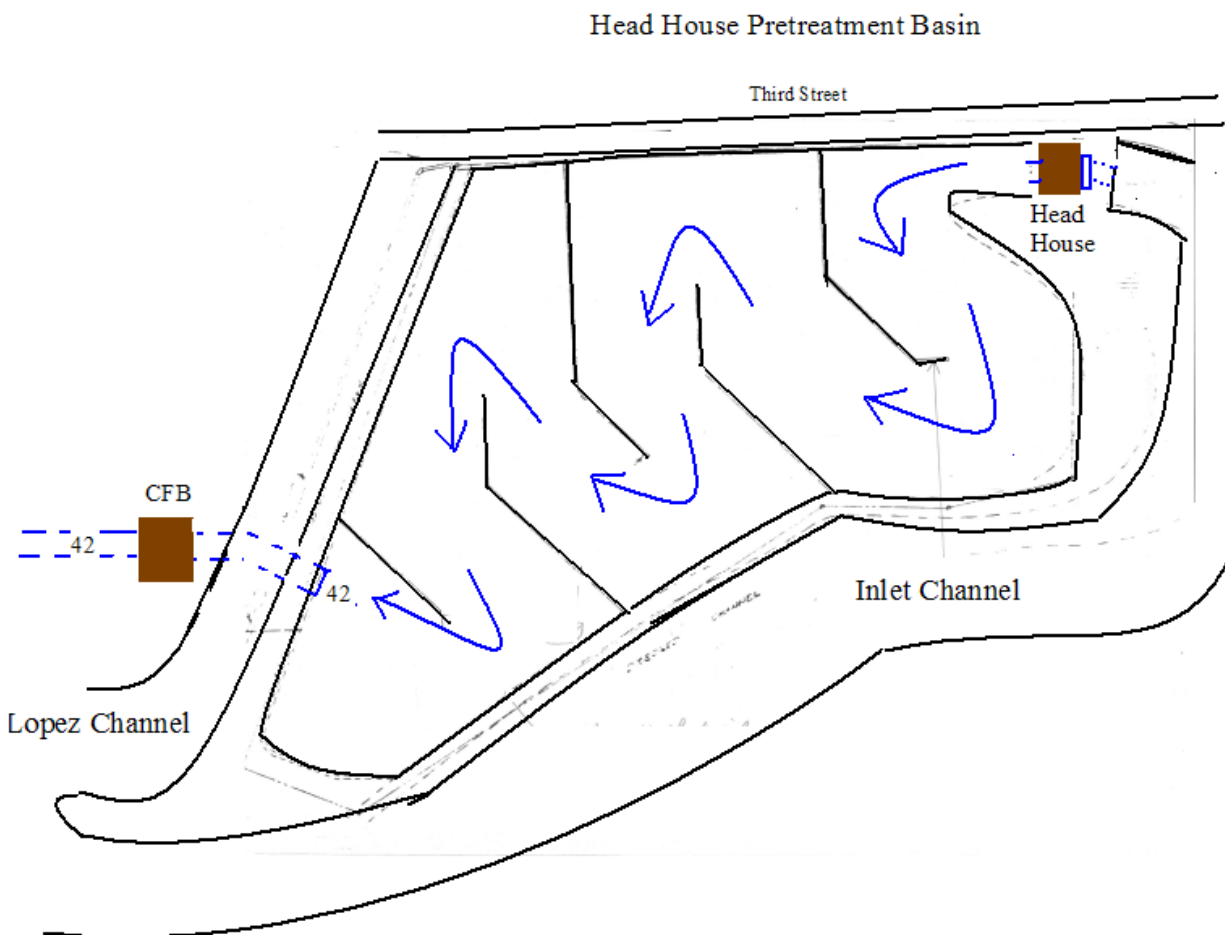



Emergency Intakes: Menasha Utilities has two additional emergency intakes located on the north bank of the Fox River adjacent to the water plant. One intake pipe is 24” in diameter, the second is a 16” diameter pipe. These intakes are to be used in emergency situations only.

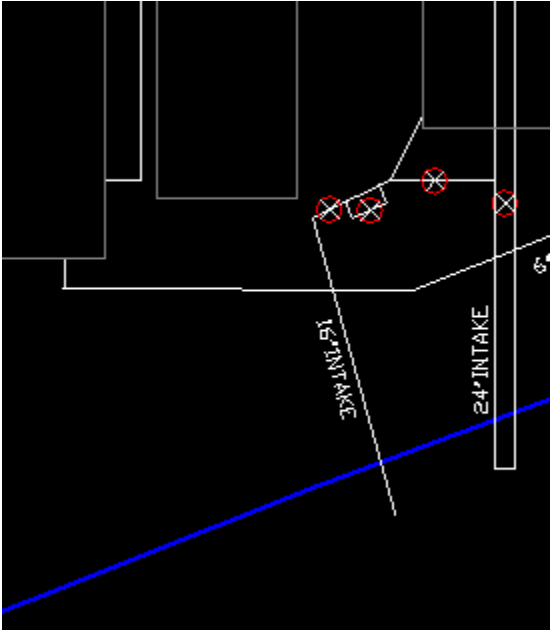

Our current intake has been identified as a “non-conforming feature” by the Wisconsin Department of Natural Resources during our most recent sanitary survey. Their comment states, “The existing intake is non-conventional and does not conform to the requirements of NR 811.22, Wis. Adm. Code”. This is not a deficiency but does not conform to current standards for community systems.

Menasha Water Plant Flow

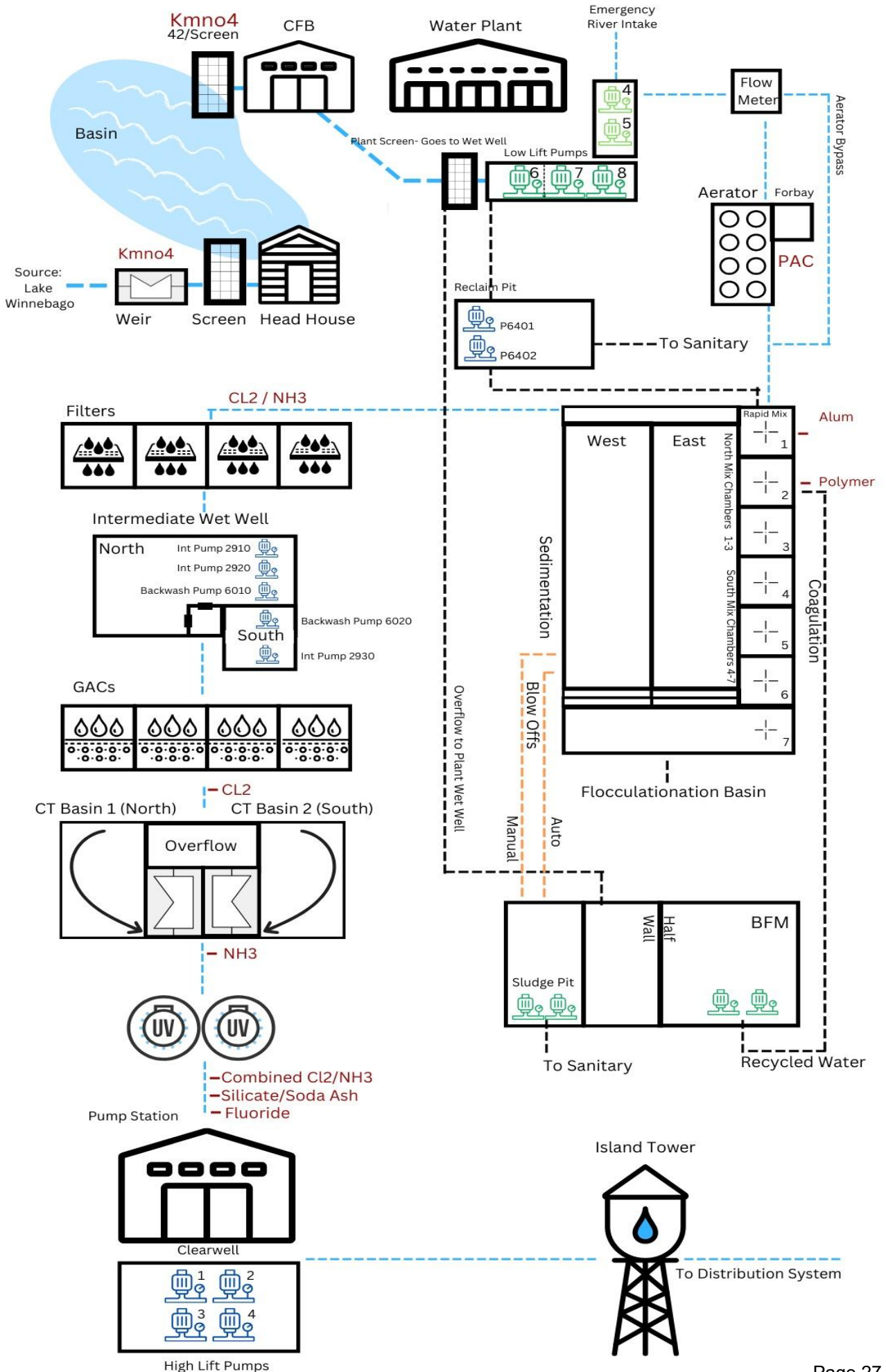

Aeration: Water flows from the Chemical Feed Building through a 42” concrete pipe to the Water Plant raw water wetwell. Up until this point gravity has been used to move water through the system. There are 5 Low Lift Pumps: LLP 4 – 2.5 MGD, LLP 5 – 2.5 MGD, LLP 6 – 5.0 MGD, LLP 7 – 5.0 MGD, and LLP 8 – 5.0 MGD. Water is pumped via a 20” pipe to the aeration basin located on top of the settling basins where a series of 4” nozzles spray the water into the air. Aeration allows volatile gases to dissipate into the atmosphere. As the water falls to the basin floor, it is collected in a drain called the “Forebay”. The forebay is a 4 x 4 cement box in the northeast corner of the west basin. At this point, Powdered Activated Carbon is injected for taste and odor absorption. Water is then diverted into a 24” pipe and flows to the mixing chambers. During winter months the aeration basin is bypassed to prevent ice accumulation.

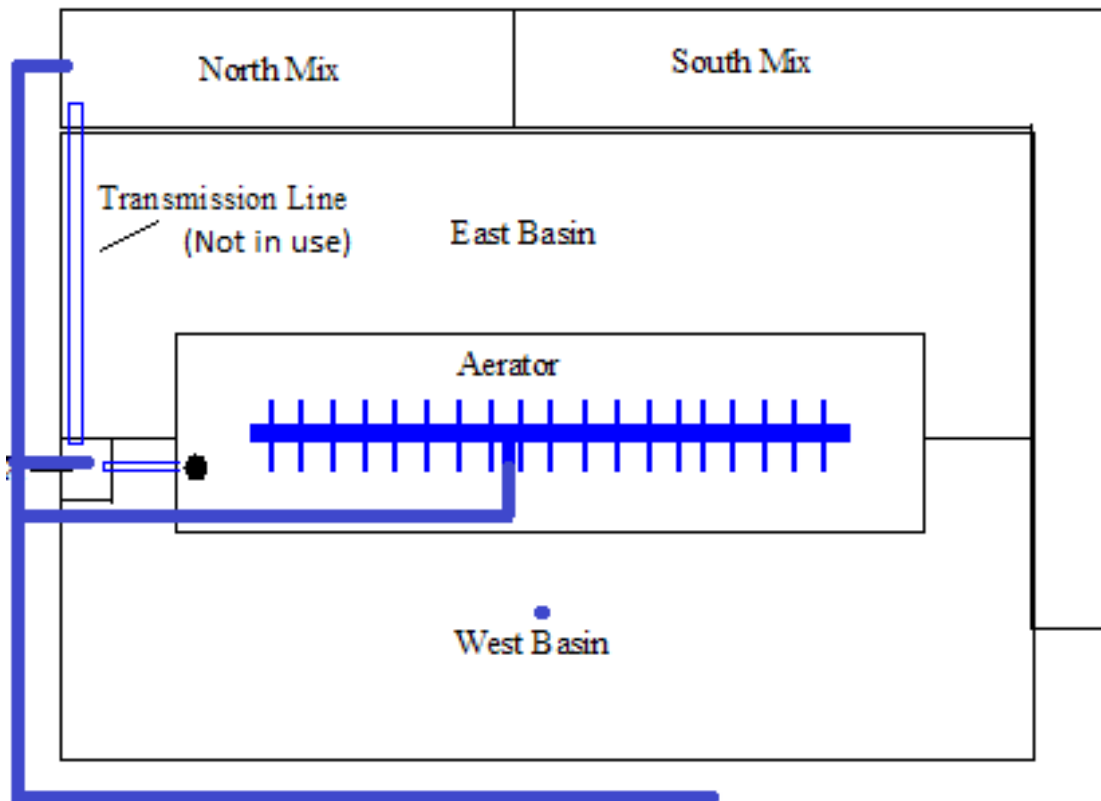

Coagulation, Flocculation, and Sedimentation. The Menasha Water Plant utilizes conventional surface water treatment. The coagulation and flocculation process takes place in the mixing chambers that consist of seven compartments separated by baffling walls. Each compartment has a Philadelphia mixer with adjustable speeds. Water flows into compartment 1 of the north mixing chamber and is dosed with our primary coagulant, Aluminum Sulfate (alum). The alum feed is combined with carrier water and pumped into a target plate. This high velocity injection helps disperse the alum and intensify mixing. In chamber 2, a cationic polymer is injected to aid in coagulation. The mixer speed is highest in compartment one and lowest in compartment 7. The mixers decrease speed as water flows through each subsequent compartment. This allows adequate mixing and floc formation as water flows through the mixing chambers.

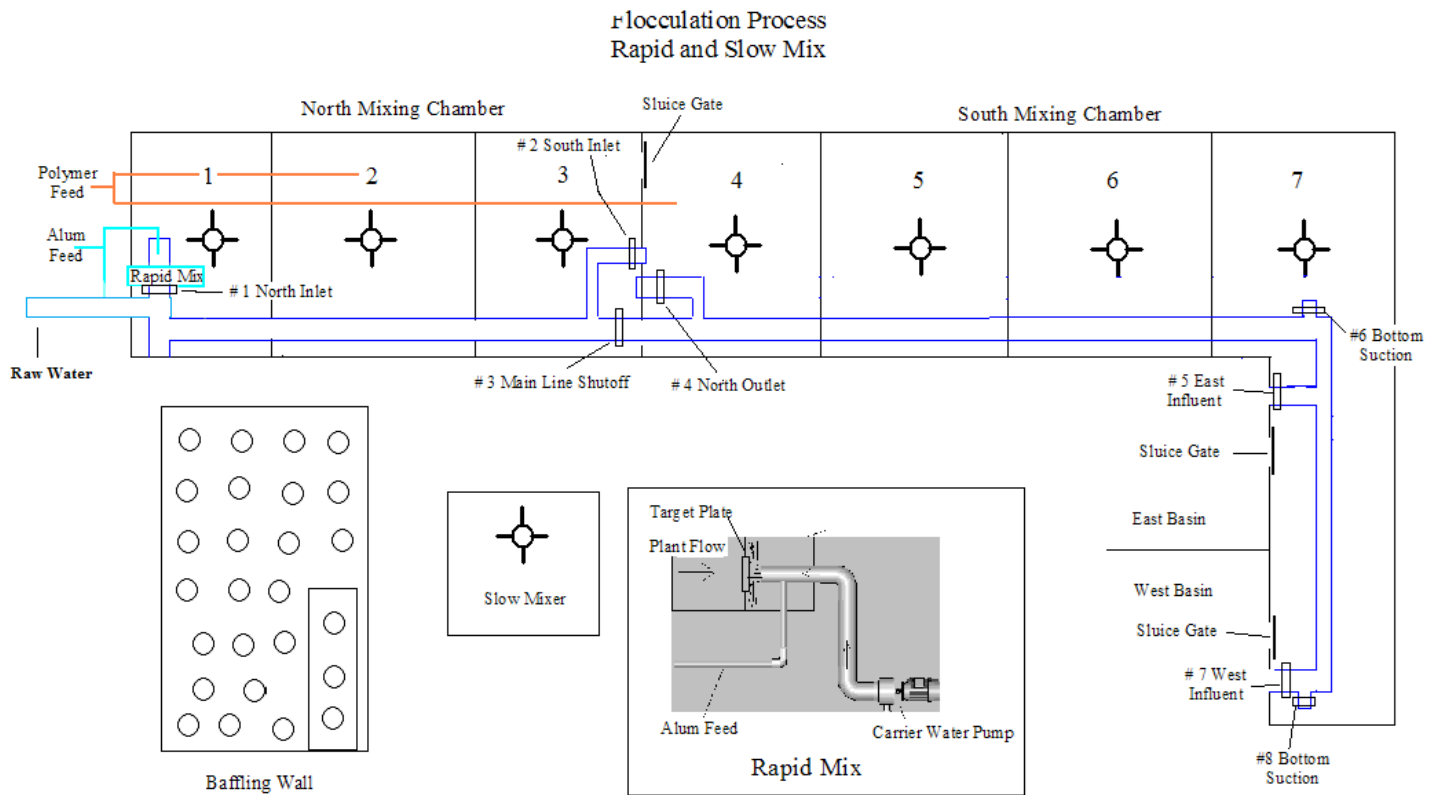

Following coagulation and flocculation in the Mixing Chambers, water enters the larger sedimentation basins. At this point, the velocity of the water slows down and allows the large, flocculated particles to settle out. The floc accumulates on the bottom of the sedimentation basin and is periodically discharged to the sanitary sewer collection system. The sanitary sewer collection system can sustain the flow of settled solids as well as the water discharged from customers in the MU service area.

Filtration: Settled water leaves the settling basins and enters the dual media filters through a filter inlet channel. A combination of sodium hypochlorite and aqua ammonia (chloramines) can be fed at this point. Menasha Water Plant has 4 filters with 4 feet of anthracite and 1 foot of sand. Each filter is 360 square feet and has a maximum filtering rate of 3 gpm/sq.ft.. The filters are backwashed using air and filtered water or a combination of both. The maximum air scour rate is 5 CFM/sq.ft. or 1800 CFM. The maximum washwater rate is 20 gpm/sq.ft. or 7200 gpm. All washwater is recycled to the raw water wetwell or the north mixing chamber.

Granular Activated Carbon Contactors: Filter effluent is pumped from the intermediate wetwell to the GAC inlet using any combination of 3 intermediate vertical turbine pumps. The filtered water is evenly distributed to 4 GAC contactors. Each contactor is 360 square feet with 4 feet of granular activated carbon media. Normal filtering rate is 2 gpm/sq.ft. with a maximum filtering rate of 6 gpm/sq.ft.. The GAC contactors are backwashed using air and filtered water or a combination of both. The maximum air scour rate is 5 CFM/sq.ft. or 1800 CFM. The maximum washwater rate is 20 gpm/sq.ft. or 7200 gpm. All washwater is recycled to the raw water wetwell or the first compartment of the mixing chamber.

Free Chlorine CT: GAC contactor effluent flows into CT basins where sodium hypochlorite is injected for virus inactivation. Menasha Water Plant has 2 CT basins that are 114,600 gallons in volume each. The CT basins can be run in parallel but most often only one basin is needed. Aqua ammonia can be injected to form chloramines as water leaves the CT basin but typically is not utilized.

UV Disinfection: Water leaving the CT basins is collected into a common header and flows through 2 Trojan UV Swift 24” reactors that run in parallel. Each reactor has 4 lamps and can treat 12 MGD. Normal operation is to operate one reactor at a time and switch reactors monthly. UV is used as a primary disinfectant, providing giardia and cryptosporidium inactivation. Immediately following UV disinfection soda ash is injected for pH adjustment, sodium silicate is added as a corrosion inhibitor, a combination of sodium hypochlorite and aqua ammonia are added for secondary disinfection, and sodium fluorosilicate is added for teeth protection.

High Lift Pumping Station (HLPS): After UV disinfection and chemical treatment, water flows from the water plant to the 3.0 MG clearwell. The clearwell has a baffle wall configuration to prevent short circuiting and can be isolated to the north or south half for maintenance and inspection. Normal operation is to run the clearwell in series to gain the most detention time. The HLPS is part of the clearwell storage facility. The HLPS can also be isolated to the east or west wetwells for maintenance and inspection. Each side of the wetwells have two vertical turbine pumps on variable frequency drives to pump water to the distribution system and elevated storage tower. Normal operation is to utilize both wetwells so any combination of pumps can be operated.

High Lift Pump Station

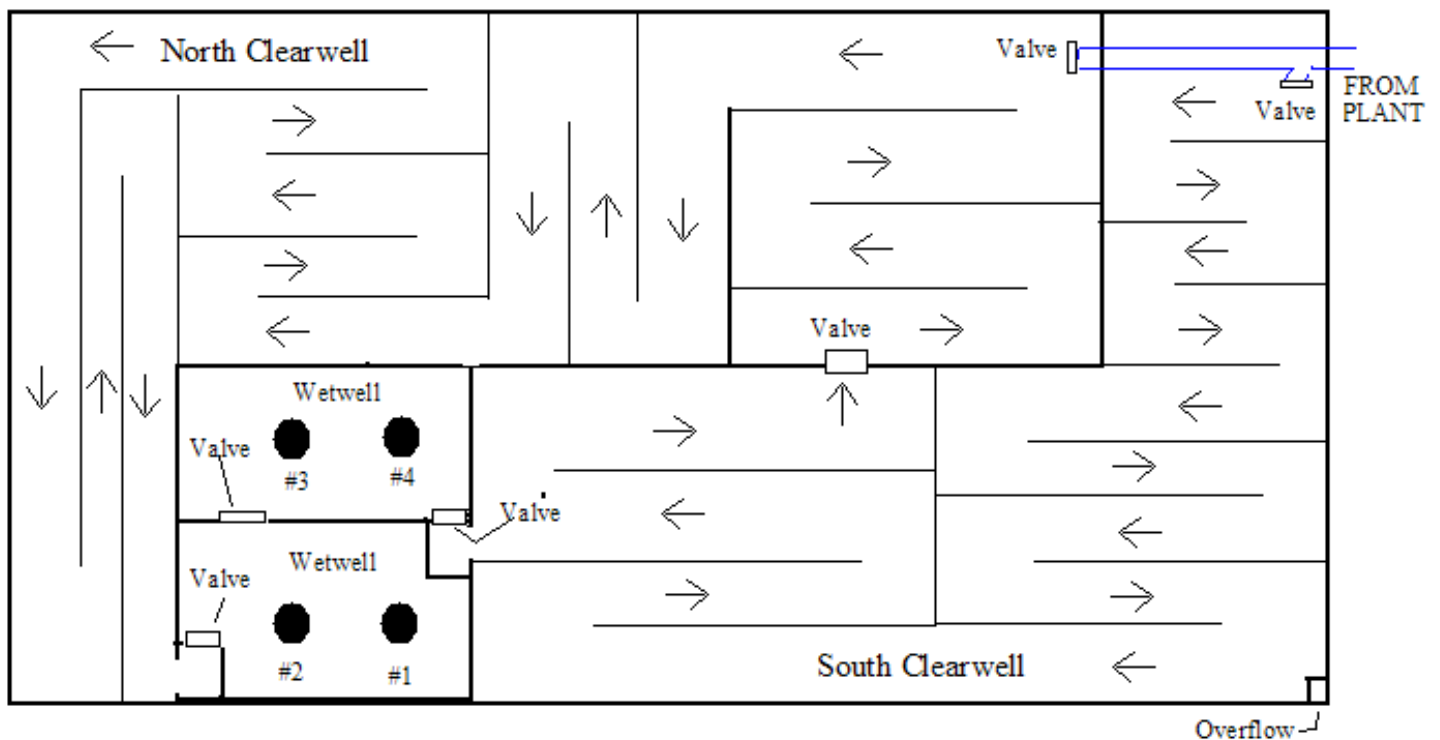

Elevated Storage: Menasha Utilities has 1 elevated storage tank with a storage volume of 750,000 gallons.

Auxiliary Power: The water plant has a 350 KW back-up diesel fuel generator with a 350-gallon fuel tank. The approximate fuel usage is 21 gallons per hour. This generator has the capability of running at least one pump for each treatment operation. The HLPS has a 350 KW back-up diesel fuel generator with a 600-gallon fuel tank. The approximate fuel usage is 36 gallons per hour. This generator can run at least 3 high lift pumps at once.

Consecutive Systems: Menasha Utilities serves 1 consecutive system; The Village of Fox Crossing. The Village of Fox Crossing blends MU's surface water with groundwater they pump from their wells on the East Side water system. Below is a map of The Village of Fox Crossing's East Side water district. This plan does not consider serving other consecutive systems.

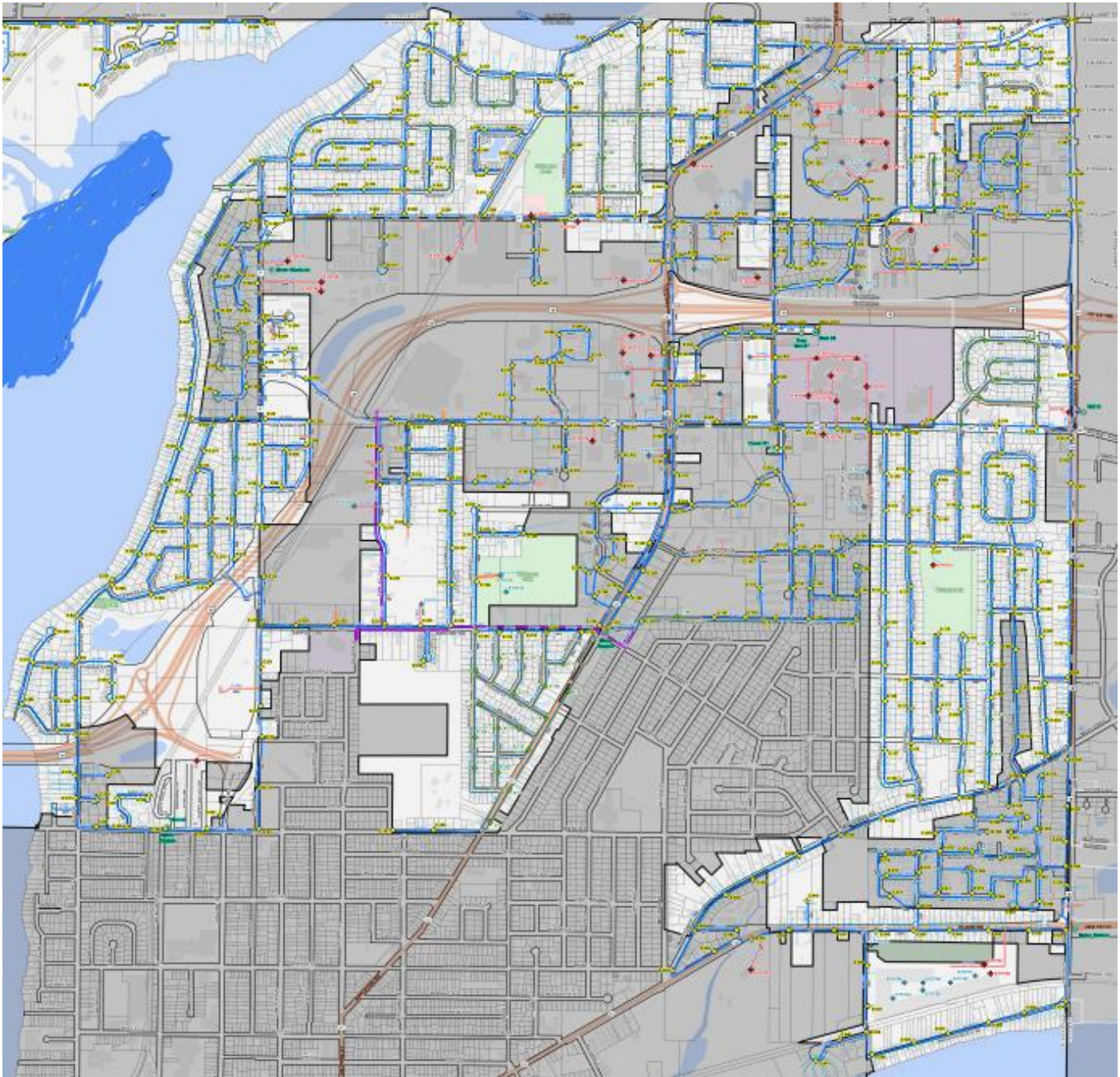

2.4 Existing sources and withdrawals

Withdrawals: The Water Use Individual Permit for Menasha Utilities (property #275) authorizes a total property withdrawal amount of 6,010,000 gallons per day. The volume can be a combined total from the 3 intake pipes that serve the Menasha Water Plant. The 3 intake pipe names are; Raw Water Intake, Emergency River Shore Intake, and Emergency River Intake. Primarily only the Raw Water Intake is used. The maximum withdrawal capacity cannot exceed 6,010,000 gallons per day without applying to the DNR for a modified permit.

Annual Withdrawal:

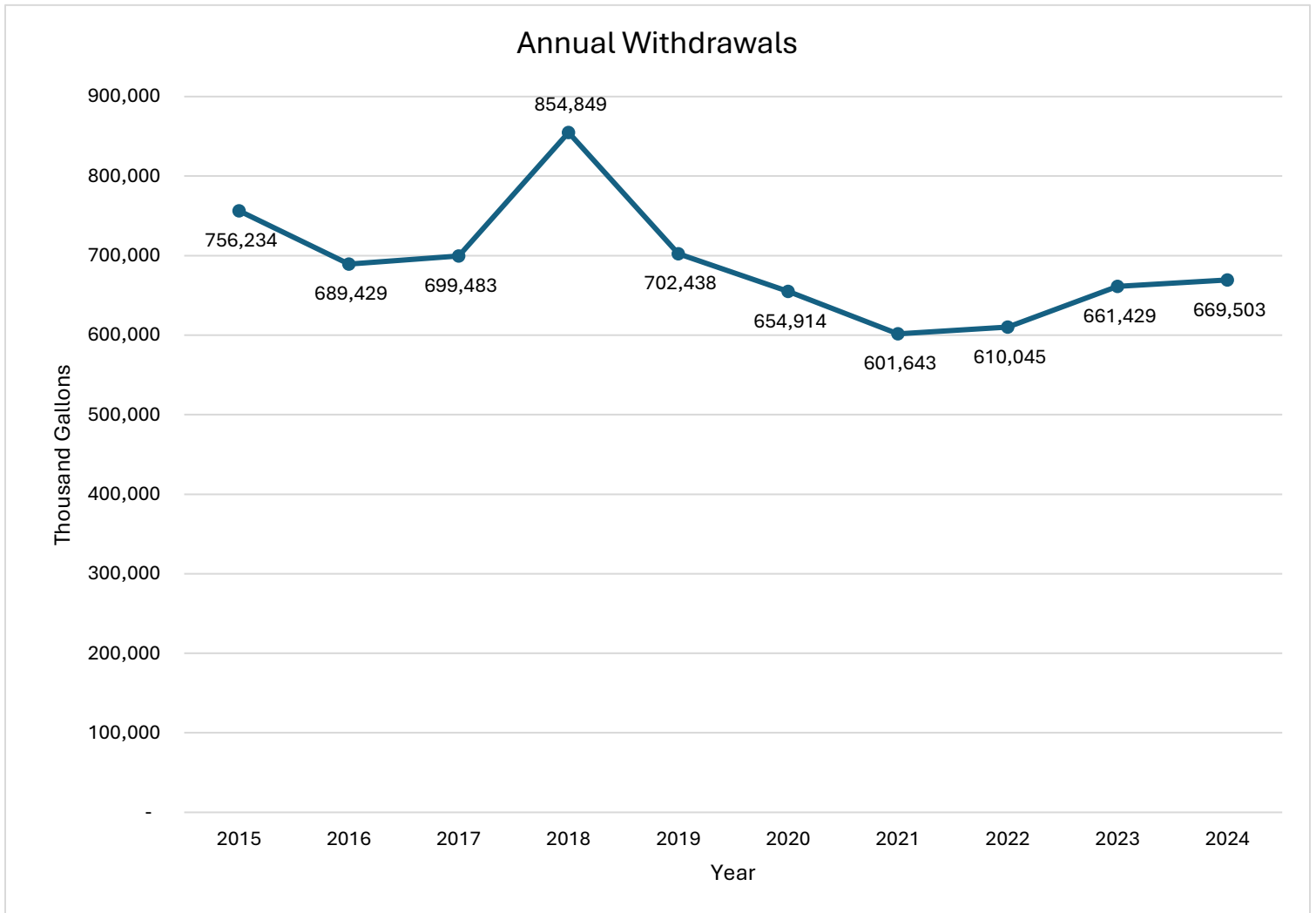

Average Daily Withdrawal:

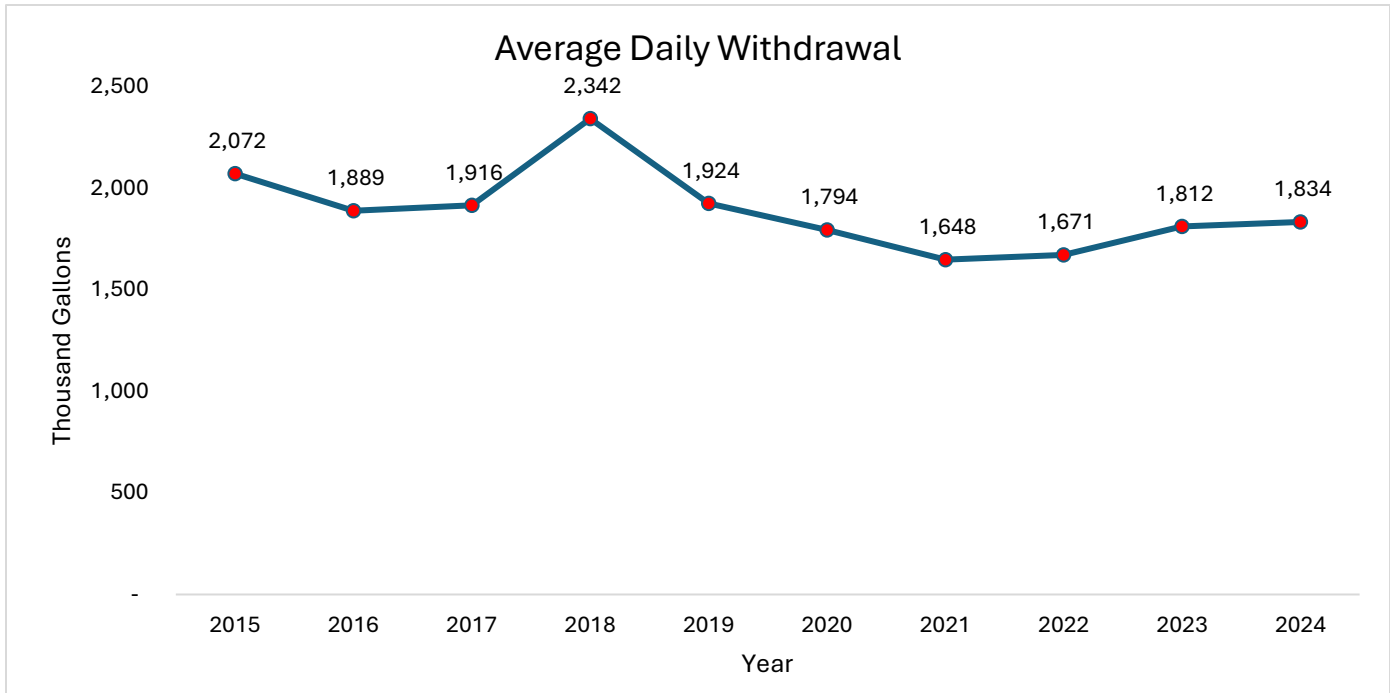

Annual Maximum Daily Pumpage:

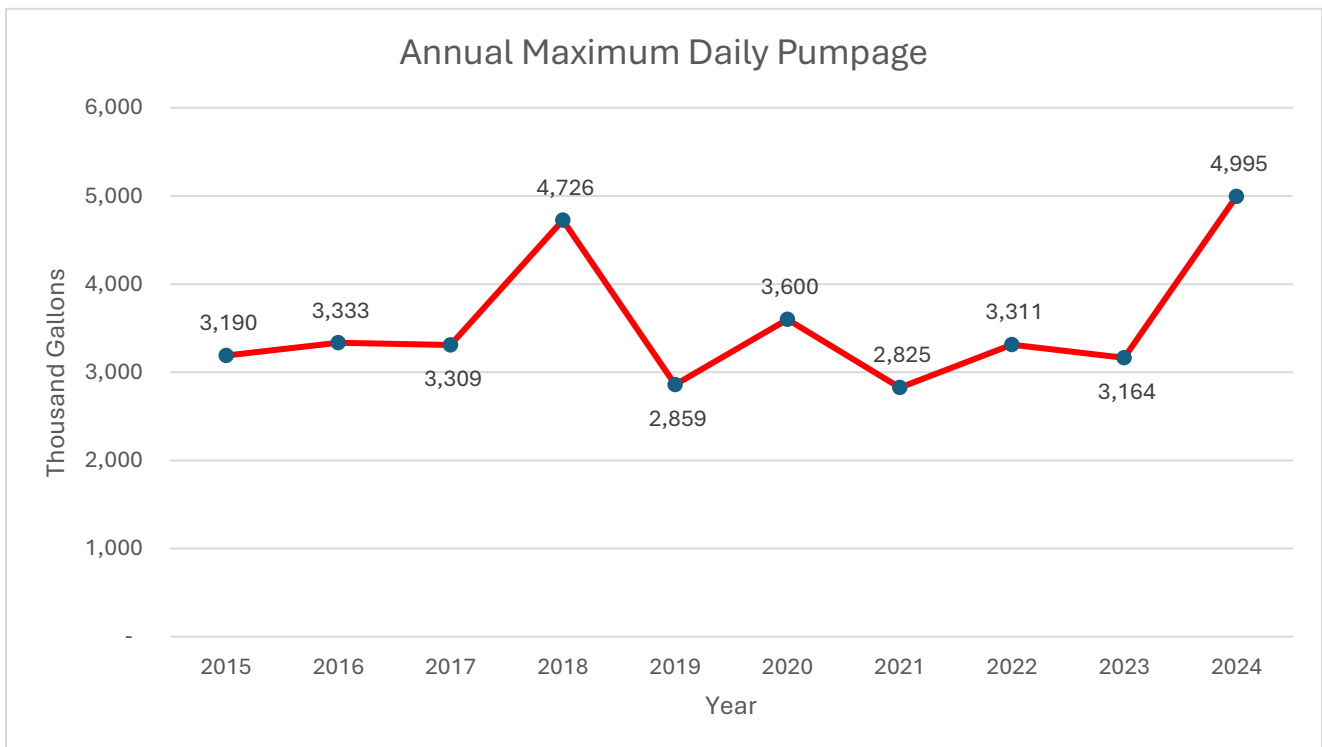

2.5 Existing Water Use

Population and Population Density: The population of Menasha Wisconsin is 18,268 according to the 2020 census. However, Menasha Utilities' service area only consists of 15,144 people.

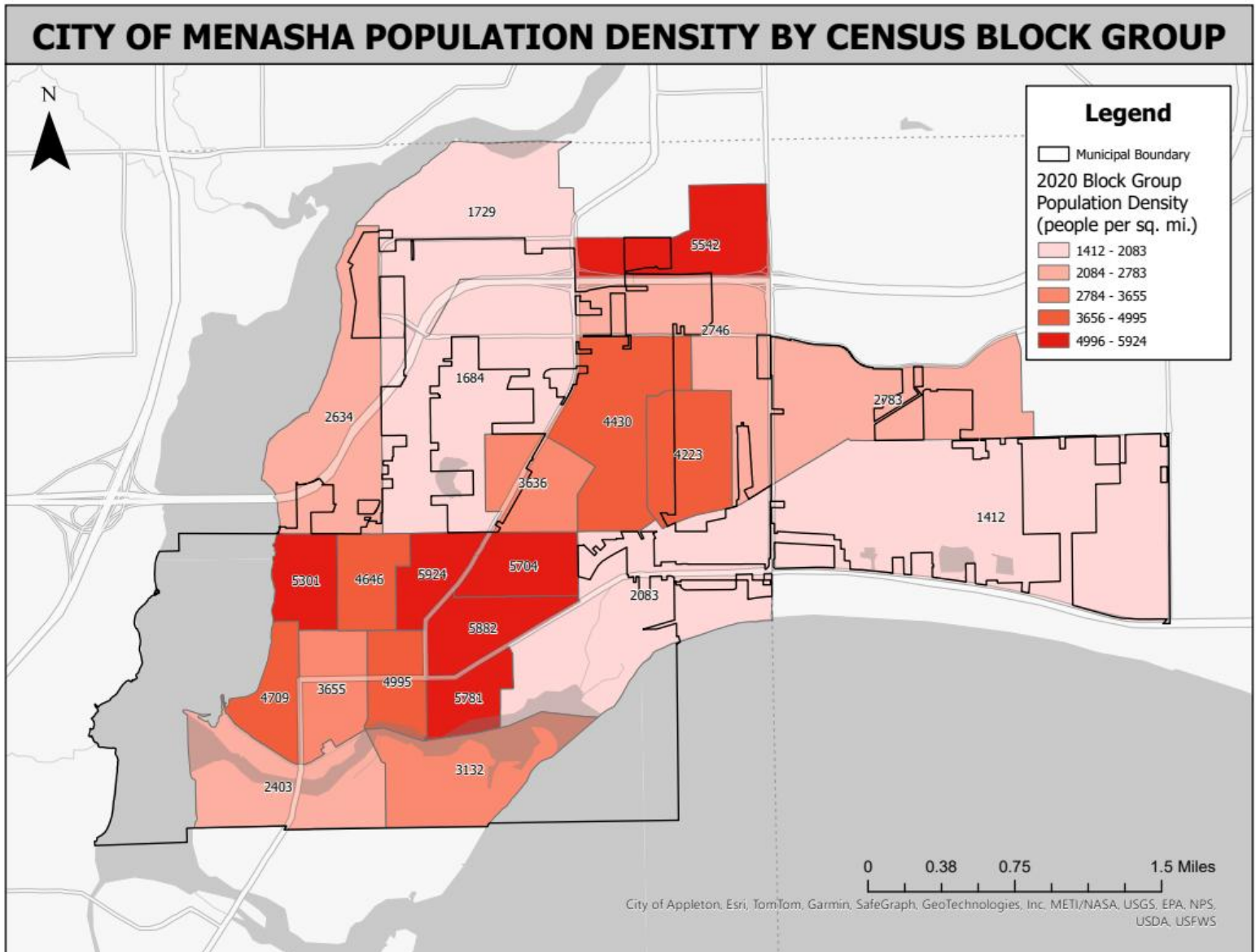

Retail Customers:

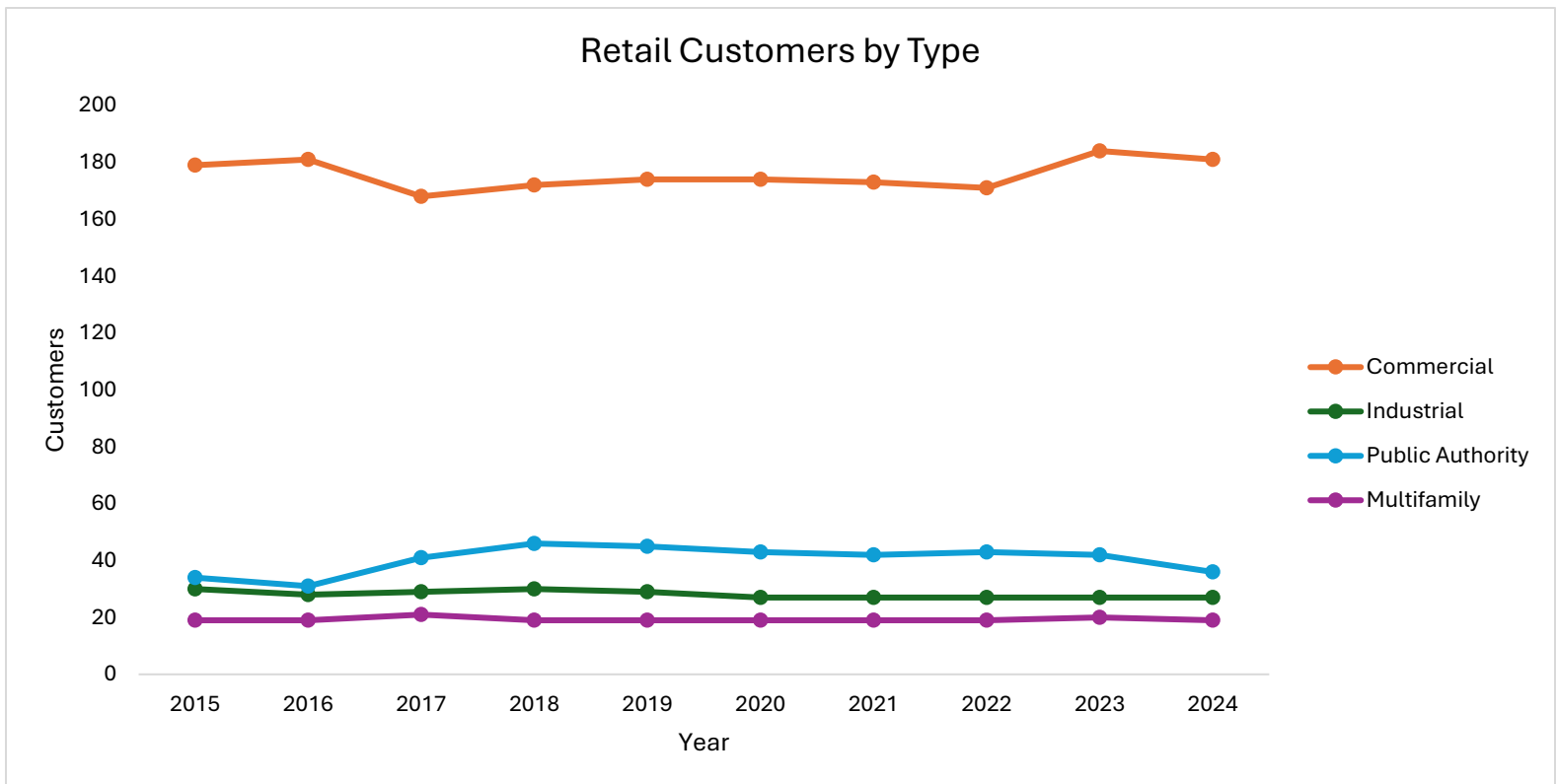
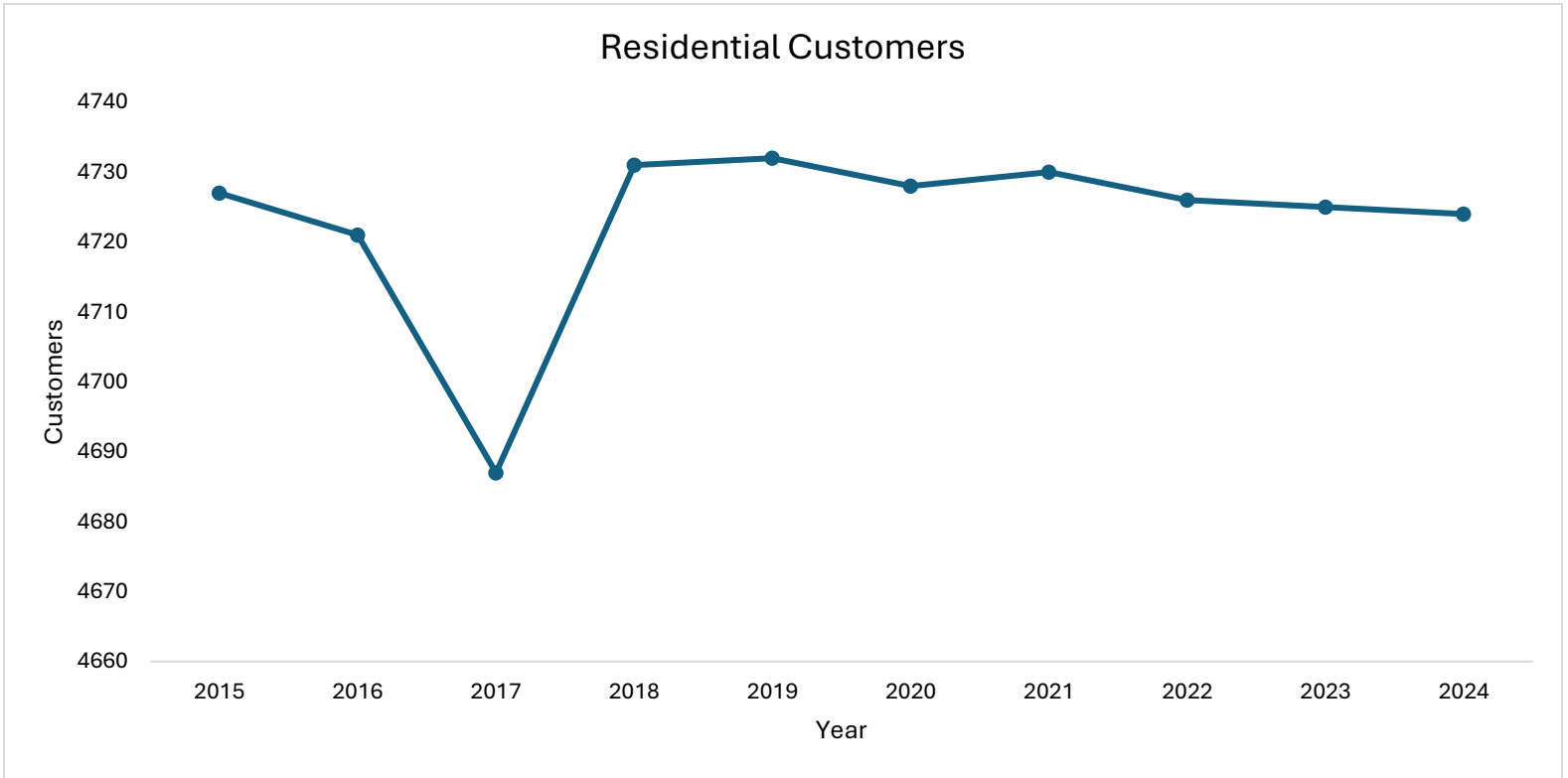

	2015	2016	2017	2018	2019	2020	2021	2022	2023	2024
Residential	4727	4721	4687	4731	4732	4728	4730	4726	4725	4724
Commercial	179	181	168	172	174	174	173	171	184	181
Industrial	30	28	29	30	29	27	27	27	27	27
Public Authority	34	31	41	46	45	43	42	43	42	36
Multifamily	19	19	21	19	19	19	19	19	20	19
Total	4989	4980	4946	4998	4999	4991	4991	4986	4998	4987

Sales of Water by Customer Type:

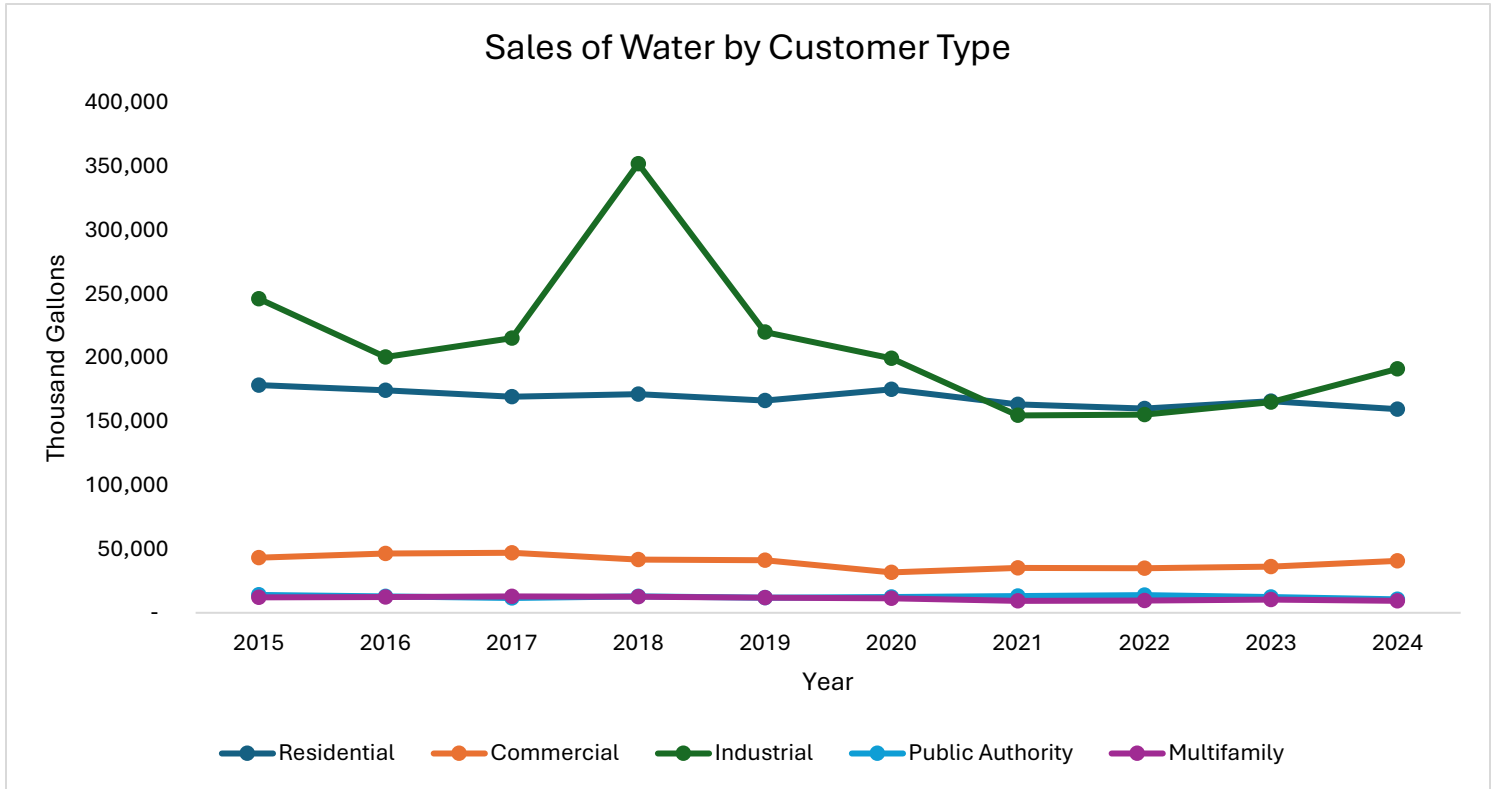

(000) Gallons	2015	2016	2017	2018	2019	2020	2021	2022	2023	2024
Residential	178,635	174,649	169,614	171,645	166,513	175,295	163,547	160,148	165,926	159,750
Commercial	43,159	46,528	47,084	41,781	41,255	31,706	35,155	35,039	36,232	40,801
Industrial	246,242	200,721	215,382	352,344	220,276	199,755	154,835	155,542	165,145	191,429
Public Authority	14,027	12,871	11,684	12,780	11,796	12,427	13,018	13,967	12,255	10,574
Multifamily	11,992	12,246	12,842	12,494	11,885	11,274	9,469	9,520	10,322	9,390
Total	494,055	447,015	456,606	591,044	451,725	430,457	376,024	374,216	389,880	411,944

Largest Retail Customers:

2015

CUSTOMER RANK	ACCOUNT NUMBER	THOUSAND GALLONS	WATER BILLING
1	3289410	85,616	\$455,013.60
2	3288710	12,915	\$83,428.90
3	3289350	11,345	\$67,484.50
4	1021058	8,085	\$53,427.00
5	3289740	5,410	\$36,842.00
6	3288800	3,302	\$25,644.20
7	3289553	2,791	\$19,258.20
8	3288525	2,428	\$20,061.50
9	3289670	2,164	\$0.00
10	1060100	2,038	\$15,894.00

2016

CUSTOMER RANK	ACCOUNT NUMBER	THOUSAND GALLONS	WATER BILLING
1	3289410	71,267	\$381,833.70
2	3289350	21,918	\$128,281.80
3	3288710	12,925	\$83,555.80
4	3288705	9,285	\$51,941.42
5	1021058	8,616	\$56,719.20
6	3288800	4,575	\$33,537.00
7	3289060	4,211	\$23,007.10
8	3289740	4,140	\$28,964.50
9	3289553	2,812	\$19,389.80
10	3288525	2,733	\$21,948.90

2017

CUSTOMER RANK	ACCOUNT NUMBER	THOUSAND GALLONS	WATER BILLING
1	3289410	76,581	\$408,935.10
2	3289060	60,393	\$326,376.30
3	3289350	22,857	\$133,070.70
4	3289390	21,018	\$125,563.80
5	3288710	14,948	\$94,426.40
6	1021058	8,996	\$59,075.20
7	3288800	5,306	\$38,069.20
8	3289740	3,377	\$24,237.40
9	3289553	3,136	\$21,399.10
10	3288525	2,740	\$21,915.90

2018

CUSTOMER RANK	ACCOUNT NUMBER	THOUSAND GALLONS	WATER BILLING
1	3289410	80,549	\$441,291.33
2	3289060	75,123	\$413,652.33
3	3289350	21,485	\$130,849.40
4	3289390	21,007	\$129,790.13
5	3288710	16,313	\$105,500.27
6	1021058	9,246	\$62,739.77
7	3289740	3,520	\$26,076.90
8	3288800	3,473	\$26,967.20
9	3289553	3,354	\$23,601.42
10	3288830	2,804	\$19,979.82

2019

CUSTOMER RANK	ACCOUNT NUMBER	THOUSAND GALLONS	WATER BILLING
1	3289410	85,321	\$472,685.30
2	3289060	75,974	\$423,146.20
3	3289390	22,034	\$137,264.20
4	3289350	19,127	\$119,817.10
5	3288710	11,107	\$77,567.35
6	1021058	10,924	\$74,894.95
7	3289075	5,485	\$57,982.60
8	3289553	3,477	\$24,754.35
9	3289740	3,199	\$24,387.95
10	2203535	2,794	\$18,741.46

2020

CUSTOMER RANK	ACCOUNT NUMBER	THOUSAND GALLONS	WATER BILLING
1	3289410	38,771,622	\$388,107.90
2	3289060	31,355,413	\$352,990.10
3	3289390	9,752,698	\$128,816.00
4	3289075	9,206,766	\$133,411.80
5	3289350	7,706,837	\$94,853.85
6	1021058	3,819,842	\$46,486.45
7	3288710	3,798,834	\$55,453.95
8	3288525	3,013,781	\$34,638.80
9	3289553	2,223,759	\$28,055.55
10	3289740	1,731,646	\$25,556.80

2021

CUSTOMER RANK	ACCOUNT NUMBER	THOUSAND GALLONS	WATER BILLING
1	3289410	60,292,000	\$340,031.60
2	3289060	44,332,000	\$255,443.60
3	3289390	20,929,000	\$131,407.70
4	3289350	16,127,000	\$103,875.85
5	1021058	8,132,000	\$56,708.60
6	3288710	7,067,000	\$51,772.85
7	3288525	3,909,000	\$30,417.80
8	3289740	3,279,000	\$24,921.45
9	3288830	2,819,000	\$20,444.00
10	3289550	2,602,000	\$22,526.40

2022

CUSTOMER RANK	ACCOUNT NUMBER	THOUSAND GALLONS	WATER BILLING
1	3289410	47,198,000	\$277,746.91
2	3289060	45,845,000	\$270,923.74
3	3289390	25,207,000	\$158,151.99
4	3289350	14,162,000	\$95,678.71
5	3289075	11,014,000	\$93,021.52
6	1021058	9,474,000	\$66,971.98
7	3288710	7,330,000	\$54,899.93
8	3288525	5,125,000	\$38,636.61
9	3289740	3,259,000	\$25,459.12
10	3288830	2,638,000	\$19,730.19

2023

CUSTOMER RANK	ACCOUNT NUMBER	THOUSAND GALLONS	WATER BILLING
1	3289060	49,427,000	\$295,174.54
2	3289410	40,482,405	\$245,621.47
3	3289390	24,785,000	\$158,657.86
4	3289075	24,331,000	\$168,903.82
5	1021058	12,286,105	\$86,599.68
6	3289350	10,086,000	\$72,605.40
7	3288710	5,514,000	\$43,464.72
8	3288525	3,795,000	\$30,549.25
9	3289550	3,187,000	\$27,547.92
10	3289740	3,102,049	\$24,874.22

2024

CUSTOMER RANK	ACCOUNT NUMBER	THOUSAND GALLONS	WATER BILLING
1	3289060	55,278,383	\$360,062.82
2	3289410	43,142,000	\$281,865.70
3	3289075	38,440,000	\$274,624.99
4	3289390	24,889,000	\$175,140.93
5	1021058	13,831,845	\$104,753.34
6	3289350	10,671,443	\$84,743.87
7	3288800	5,068,745	\$44,294.47
8	3289550	4,318,000	\$40,130.43
9	3289740	3,283,367	\$30,011.55
10	3288710	2,765,000	\$26,884.19

Sales of Water to Consecutive Water System: Water sales to the consecutive system have seen minor fluctuations over the past 10 years. The reduction in sales from 2019 through 2021 is most likely due to the Covid-19 pandemic where commercial and industrial demand was lower. 2022 through 2024 has seen a slight uptick in demand.

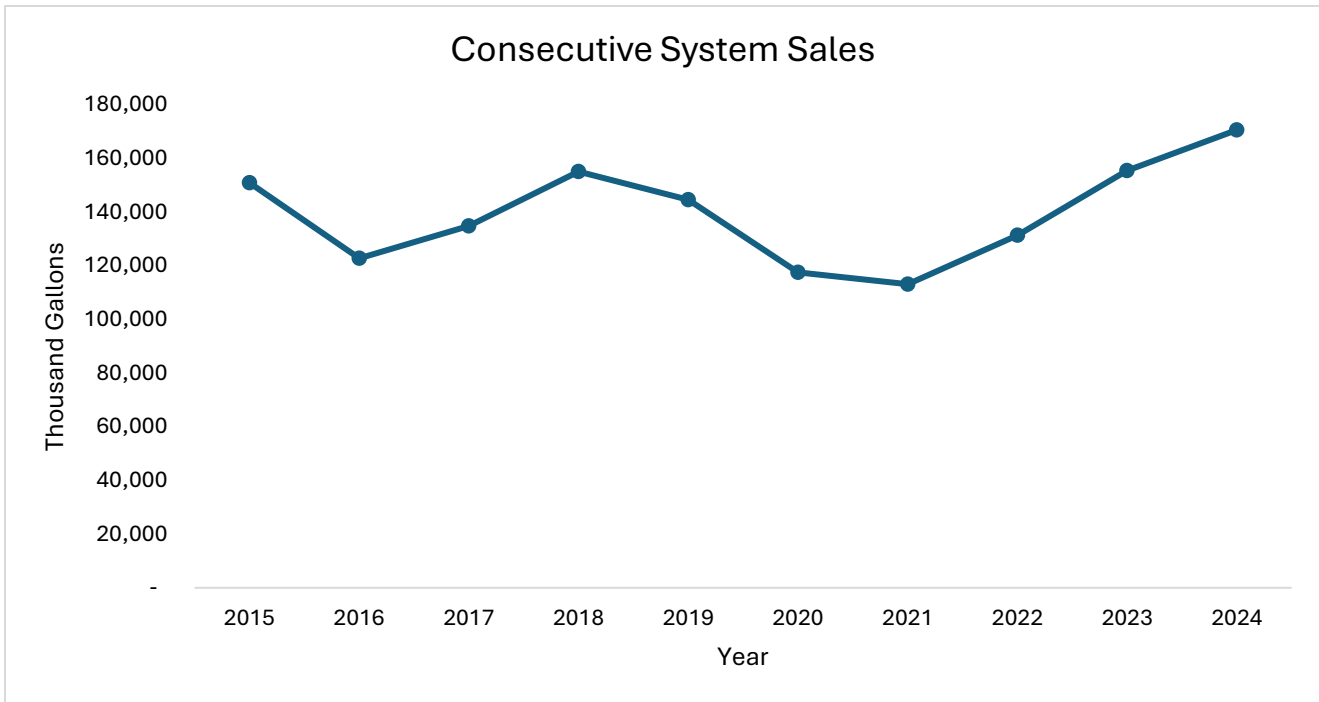

(000) Gallons	2015	2016	2017	2018	2019	2020	2021	2022	2023	2024
Consecutive System	150,991	122,837	134,893	155,106	144,585	117,511	113,170	131,402	155,463	170,649

2.6 Projected Water Demand

Projected Water Demand: The projected water demand for the planning period is expected to remain similar to the past 10 years. The Menasha Utilities service area has miniscule room to expand because it is surrounded by other public water suppliers. The City of Menasha population has grown over the past 30 years, but Menasha Utilities does not serve the entire city. The Area of Menasha that has expanded is east of Oneida Street to Lake Park Road and from STH 114 to Midway Road. Unfortunately, the areas described are not part of MU's service area. This plan does not consider projected growth areas.

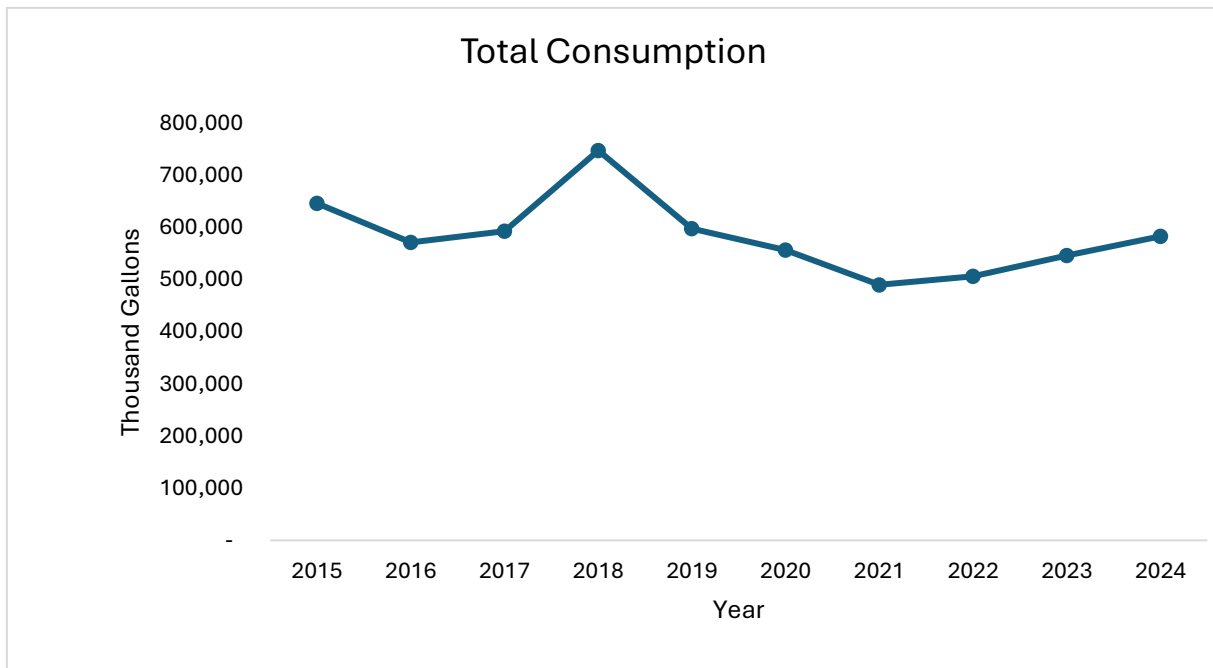
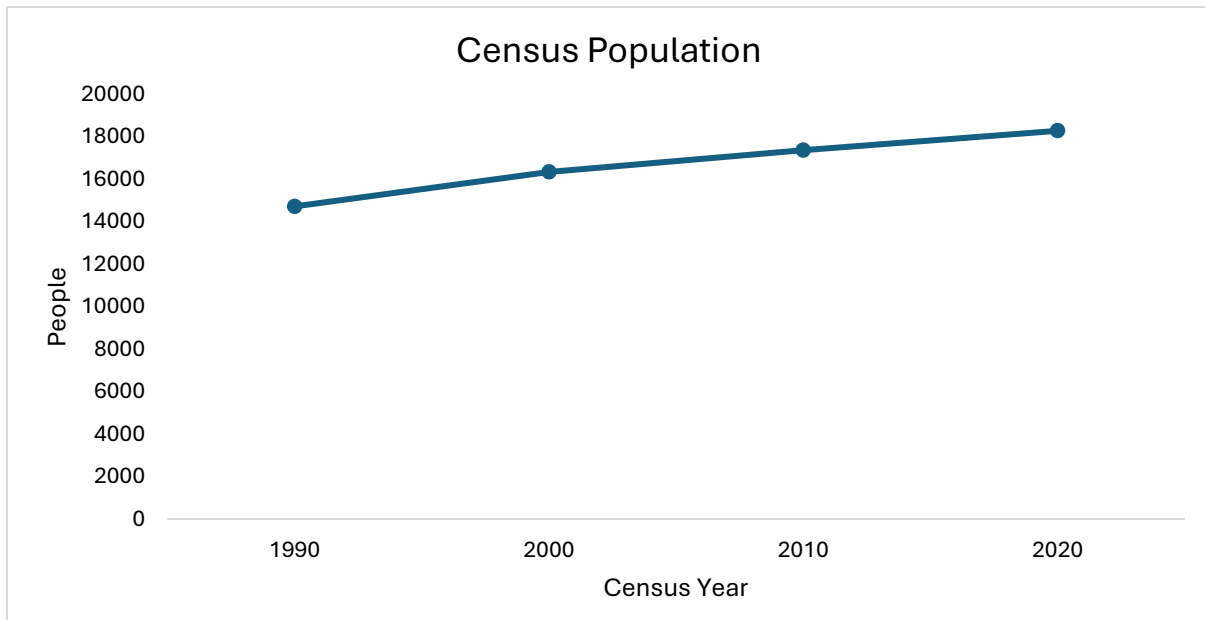

Methods Used for Projections: The methods used to derive water demand have been consumption history, sales of water to all customers, population growth, threats, and opportunities. The consumption history shows a large increase in 2018, but that was because one of our largest industrial customers had operational issues that required them to take more MU water. Consumption otherwise has been stable. Water sales for all customer types are consistent and similar to the consumption trend. The City of Menasha is showing population growth, but the growth areas are not in MU's service area, therefore population will not affect water demand. Menasha Utilities has minimal opportunities to increase water demand. A large industrial customer could relocate to Menasha, but that hasn't happened in many years. The largest threat to water demand would be losing large industrial customers or the consecutive system. Over the past 10 years our largest customers have been unvarying.

Projected Sales of Water to Consecutive Systems: MU has one consecutive system, The Village of Fox Crossing. The 10-year historical sales trend shows their water demand has fluctuated gradually over time. Most recently the trend shows a slight increase in sales. The Village of Fox Crossing's East water district has minimal room for projected growth. The projected sales of water to the consecutive system are expected to remain constant for the planning period.

2.7 Inventory and Identification

Identification: Menasha Utilities Water Plant has the capability of treating water to the highest standard that meets all local, state, and federal codes. Lake Winnebago has abundant surface water that is conveniently obtainable. The Fox River flows adjacent to the Menasha water plant from Lake Winnebago to Green Bay. Any withdrawal from the Fox River is essentially taking from Lake Winnebago. Groundwater could be explored but the amount of hardness, arsenic, and potential emerging contaminants (PFAS) in the water would make treatment impractical and extremely costly to perform. Purchasing water from a neighboring community was explored during MU's 2015 source water study. The cost to purchase raw water and provide infrastructure to connect raw water lines was deemed uneconomical.

2.8 Plan Recommendation

Recommendation: The most cost effective and feasible method to meet water demand of the public water system is to continue to withdraw water from the head house on Lake Winnebago, treat the water at the Menasha Water Plant, and distribute to the Menasha

service area. This method provides the most operational control and ability to adapt to water demands. The 6 MGD capacity is sufficient to satisfy demand according to the information provided in this plan.

2.9 Analysis of consistency with other plans

Consistency With Other Plans: This plan is consistent with other applicable local, regional, and organizational plans. The information provided in this plan aligns with existing goals, policies, and strategies and does not conflict with previously adopted plans.

The information contained in this plan was developed using data from the following sources:

- Wisconsin Public Service Commission annual reports
- Existing water utility system records and operational data
- Population and demographic data (e.g., U.S. Census Bureau)
- Applicable state statutes, administrative codes, and regulatory guidance
- WDNR Water Withdrawal reports
- MU's Emergency Response Plan
- Wholesale water contract

NR 854.08

3.1 Public Participation

Process Description: The WSSAP is required to be available for public participation and must contain all written public comments. Below is a list of actions taken to include the public in this plan.

- Public notice of the proposed plan on the Menasha Utilities Commission meeting agenda.
- A link to the plan for public inspection on the Menasha Utilities website www.menashautilities.com.
- Instructions to send all written public comments on the WSSAP to asmith@menashautilities.com.
- Review of the WSSAP at the Menasha Utilities Commission meeting on 12/17/25

- Adoption or denial of the plan at the 12/17/25 Menasha Utilities Commission meeting
- Updating the WSSAP to include written public comments when received

3.2 Submission of plan to local governments

Submission of the Plan: The Menasha Utilities WSSAP was delivered via email to the Village of Fox Crossing and the City of Neenah on 12/15/25. The plan was also emailed to all MU Commissioners on 12/15/25.

3.3 Public inspection

Written Comments: All written public comments will be included below and updated when received.



MEMORANDUM

DATE: December 23, 2025
TO: Nick Thorn, Chief of Police
FROM: Austin R. Hammond, Mayor
RE: SEC. 10-1-20(b) Mayoral Suspension of Restrictions on Parking; Posted Limitations - Downtown Menasha

Chief Thorn,

Menasha Municipal Code Section 10-1-20 (b), *Suspension Powers of the Mayor*, authorizes the Mayor to suspend parking time limitations for a limited and reasonable period upon notification to the Chief of Police. Please accept this as notification that parking time limitations will be temporarily suspended in several designated parking areas in downtown Menasha between the hours of 9:00am – 5:00pm.

This suspension will be in effect from December 24, 2025, through January 31, 2026. Notwithstanding this mayoral suspension, the Overnight Parking Ban of on-street parking shall continue from 2:00am to 6:00am between November 1st and March 31st in these designated parking areas.

The affected parking areas, as shown in blue on the map on the second page, include street parking on Milwaukee Street between Broad Street and Main Street; back-in angle parking on Broad Street between Milwaukee Street and Racine Street; the West Broad Street Parking Lot; and the East Broad Street Parking Lot.



I have chosen to temporarily suspend parking time limitations in these designated areas to ease parking time burdens during the holiday season, encouraging residents and visitors to support our wonderful local downtown businesses and to spend time in downtown Menasha. In addition, I intend to work with you and Director of Public Works, James Merten, on drafting parking ordinance changes for consideration by the Board of Public Works, and if approved and recommended to the City of Menasha Common Council for its consideration and possible approval sometime in the start of 2026. My goal is to ensure that downtown Menasha remains an accessible and welcoming destination where residents and visitors are encouraged to spend time, and where local small business owners can thrive and be successful. I appreciate your anticipated cooperation and support.

Respectfully,

Austin R. Hammond, Mayor

HELP SHAPE MENASHA'S URBAN FOREST

SCAN ME



<https://forms.office.com/r/m1hmQyREd4>

No login required

We'd love to hear from you -
let us know your opinion on
trees in Menasha. Scan the
code to take our survey.



Paper Surveys are Available at City Hall, 100 Main Street, Menasha WI 54952

Your feedback helps us grow.

**This project was funded in part by an urban forestry grant from
the State of Wisconsin Department of Natural Resources Forestry
Program as authorized under s. 23.097, Wis. Stat.**



COMMON COUNCIL MINUTES
Monday, December 15, 2025 at 6:00 PM
First Floor Conference Rooms
100 Main Street, Menasha, WI

- A. CALL TO ORDER
Meeting called to order by Mayor Hammond at 6:01pm.
- B. PLEDGE OF ALLEGIANCE
The Pledge of Allegiance was recited.
- C. ROLL CALL
Present: Aids. Rand, Eisenach, Hale, Lewis, Marshall, Grade, Ropella
Absent: Ald. Perkins
Also Present: FD Sassman, CDD Dane, DPW Merten, PHD Hutter, PRD Sackett,
PC Thorn, FC Teesch, LD Kopetsky, CA Struve, Mayor Hammond, Clerk Snyder
- D. PUBLIC HEARING
- E. PUBLIC COMMENTS ON ANY MATTER OF CONCERN TO THE CITY
- F. REPORT OF DEPARTMENT OFFICERS/DEPARTMENT HEADS/STAFF/CONSULTANTS
Motion by District 7 Alderperson Grade seconded by District 6 Alderperson Marshall to receive. Motion carried on voice vote.
 - 1. Presentations:
 - 2. Minutes to Receive:
 - a. Administration Committee, 12/1/25
 - b. Board of Public Works, 12/1/25
 - c. Personnel Committee, 12/1/25
 - d. Water and Light Commission, 11/19/25
 - e. Library Board of Trustees, 10/28/25
 - f. Joint Review Board, 10/20/25, 12/1/25
 - g. Plan Commission, 12/2/25
 - h. Board of Appeals, 10/6/25
 - i. Neenah-Menasha Joint Finance & Personnel Committee, 12/9/25
 - j. Landmarks Commission, 12/10/25
 - k. Housing Authority, 12/8/25
 - 3. Communications:
 - a. Community Development Department Memo - Commercial Building

Inspections Update

G. CONSENT AGENDA

1. Common Council Minutes, 12/1/25
Motion by District 7 Alderperson Grade seconded by District 5 Alderperson Lewis to approve. Motion carried on voice vote.
2. Administration Committee, 12/1/25, Recommends Approval of:
 - a. Appointment of Election Inspectors for the Election Cycle Term of 2026-2027
Motion by District 2 Alderperson Eisenach, seconded by District 3 Alderperson Hale to approve.

Motion carried 7-0 on roll call.
3. Board of Public Works, 12/1/25, Recommends Approval of:
 - a. Change Order — Sommers Construction Co, Inc; Contract No. 2025-02; Street Construction & Rehabilitation - Various Locations; Add \$32,113.47 (Change Order No. 1 & Final)
Motion by District 8 Alderperson Ropella, seconded by District 6 Alderperson Marshall to approve.

Motion carried 7-0 on roll call.
 - b. Payment — Sommers Construction Co, Inc; Contract No. 2025-02; Street Construction & Rehabilitation; \$40,017.96 (Payment No. 3 & Final)
Motion by District 7 Alderperson Grade, seconded by District 6 Alderperson Marshall to approve.

Motion carried 7-0 on roll call.
 - c. Payment — Northeast Asphalt, Inc; Contract No. 2025-03; Jefferson Park Boat Launch; \$374,868.28 (Payment No. 4)
Motion by District 8 Alderperson Ropella, seconded by District 6 Alderperson Marshall to approve.

Motion carried 7-0 on roll call.

Staff advised that the Jefferson Park Boat Launch project recently saw completion of the first asphalt layer. Completion is expected early May 2026.
 - d. Payment — Fahrner Asphalt Sealers, LLC; Contract No. 2025-04; Asphaltic Concrete Pavement Crack Sealing - Various Locations; \$31,734.00 (Payment No. 1 & Final)
Motion by District 8 Alderperson Ropella, seconded by District 6 Alderperson Marshall to approve.

Motion carried 7-0 on roll call.

4. Personnel Committee, 12/1/25, Recommends Approval of:

- a. Updates to City of Menasha Employee Handbook, Effective January 1, 2026

Motion by District 7 Alderperson Grade, seconded by District 5 Alderperson Lewis to approve.

Motion carried 7-0 on roll call.

5. Neenah-Menasha Joint Finance & Personnel Committee, 12/9/25, Recommends Approval of:

- a. Purchase of a stock 2025 Chevrolet 1500 Silverado from Bergstrom Automotive not to exceed \$50,000 and to purchase radio, lights, graphics and other miscellaneous equipment from various vendors for a total project cost not to exceed \$67,000

Motion by District 7 Alderperson Grade, seconded by District 3 Alderperson Hale to approve.

Motion carried 7-0 on roll call.

Staff advised that the \$67,000 figure represents total expenses shared between the Cities of Neenah and Menasha.

H. ITEMS REMOVED FROM THE CONSENT AGENDA

I. ACTION ITEMS

1. Accounts Payable and Payroll for the term of 11/27/25 - 12/11/25 in the amount of \$783,082.84

Motion by District 2 Alderperson Eisenach, seconded by District 3 Alderperson Hale to approve.

Motion carried 7-0 on roll call.

J. HELD OVER BUSINESS

K. ORDINANCES AND RESOLUTIONS

L. APPOINTMENTS

Motion by District 7 Alderperson Grade seconded by District 5 Alderperson Lewis to approve. Motion carried on voice vote.

Staff advised that appointees were selected from the Redevelopment Authority, Parks and Recreation Board, and Board of Public Works.

1. Mayor's appointment of Alicia Buechler to the Lawson Canal Ad Hoc Advisory Committee as an RDA representative for the term of 12/16/25 - 9/30/26
2. Mayor's appointment of Matt Vanderlinden to the Lawson Canal Ad Hoc Advisory Committee as an RDA representative for the term of 12/16/25 - 9/30/26
3. Mayor's appointment of Richard Sturm to the Lawson Canal Ad Hoc Advisory Committee as a Parks and Recreation Board representative for the term of 12/16/25 - 9/30/26
4. Mayor's appointment of Eli Wickman to the Lawson Canal Ad Hoc Advisory Committee as a Parks and Recreation Board representative for the term of 12/16/25 - 9/30/26
5. Mayor's appointment of Ald. Hale to the Lawson Canal Ad Hoc Advisory Committee as a Board of Public Works representative for the term of 12/16/25 - 9/30/26
6. Mayor's appointment of Ald. Rand to the Lawson Canal Ad Hoc Advisory Committee as a Board of Public Works representative for the term of 12/16/25 - 9/30/26

M. CLAIMS AGAINST THE CITY

1. Claim Against the City - Village of Harrison Notice of Injury and Notice of Claim Against the City Re: 2019 Interim Agreement
 - a. Adjourn into Closed Session pursuant to Wisconsin Statute § 19.85(1)(g) Conferring with legal counsel for the governing body who is rendering oral or written advice concerning strategy to be adopted by the body with respect to litigation in which it is or is likely to become involved (Concerning Village of Harrison Notice of Injury and Notice of Claim Against the City Re: 2019 Interim Agreement)
 Motion by District 7 Alderperson Grade, seconded by District 3 Alderperson Hale to adjourn into Closed Session.

 Motion carried 7-0 on roll call.
 - b. May reconvene into Open Session to take action on items that may be pending
 Motion by District 7 Alderperson Grade seconded by District 3 Alderperson Hale to reconvene into Open Session. Motion carried on voice vote.

N. PUBLIC COMMENTS ON ANY MATTER LISTED ON THE AGENDA

O. ADJOURNMENT

Motion by District 3 Alderperson Hale seconded by District 6 Alderperson Marshall to adjourn the Common Council meeting at 6:47pm. Motion carried on voice vote.

Minutes submitted by City Clerk Kaija Snyder.



MEMORANDUM

DATE December 30, 2025
TO Honorable Mayor and Common Council
FROM Andrew Dane, Community Development Director
RE Professional Service Agreement between the City of Menasha and RG Inspections for Commercial Electric Inspection Services AND Increase of the Minimum Commercial Electric Inspection Fee

Background

On December 15th, 2025, staff recommended and the Administration Committee approved the professional service agreement between the City of Menasha and RG Inspections to provide Commercial Electric Inspection Services. Staff also recommended the Administration Committee approved an increase in the minimum commercial electric permit fee from \$50.00 to \$250.00

Following these two actions the City of Menasha received communication from a professional commercial electrician expressing desire to provide commercial electrical inspection services for the City of Menasha as a part time casual employee. This arrangement is more favorable to the City of Menasha because it allows the City to provide a higher level of service at a lower cost.

Recommendation

Staff recommend the Common Council take no action to approve the professional service agreement between the City of Menasha and RG Inspections to provide Commercial Electric Inspection Services. Staff also recommend that Common Council take no action to approve the increase of the minimum commercial electric permit fee from \$50.00 to \$250.00



MEMORANDUM

DATE December 9, 2025

TO Honorable Mayor and Common Council

FROM Andrew Dane, Community Development Director

RE Professional Service Agreement between the City of Menasha and RG Inspections for Commercial Electric Inspection Services AND Increase of the Minimum Commercial Electric Inspection Fee

Background

Attached to this memo is a draft professional service agreement (PSA) between the City of Menasha and RG Inspections to provide commercial electric inspection services on behalf of the City of Menasha.

Following the termination of the contract with ALV Inspections to provide Commercial Electric Inspections services City staff recommend contracting with RG Inspections for those same services. RG Inspections serves several municipalities in the Fox Cities and is recognized by the State of Wisconsin as a qualified Electric inspector.

Per the PSA, RG Inspections would provide commercial electric inspection services for an automatic renewing 12-month period. Either party may terminate the PSA with a 30-day written notice. Compensation is lump sum and shall be based on 90% of the permit fee secured by the City with a \$250 minimum fee.

The requirement of contracting with RG Inspections is an increase in the minimum permit fee from \$50.00 to \$250.00 and a change in fee structure to \$10 per thousand the value of the electrical project.

Recommendation

Staff recommend the Administration Committee approve the professional service agreement between the City of Menasha and RG Inspections to provide Commercial Electric Inspection Services. Staff also recommend the Administration Committee approve the increase of the minimum commercial electric permit fee from \$50.00 to \$250.00 and a change in fee structure to \$10 per thousand the value of the electrical project.

PROFESSIONAL SERVICES AGREEMENT FOR COMMERCIAL ELECTRICAL INSPECTION SERVICES

I. THE PARTIES

This Professional Services Agreement (the "Agreement") is entered into by and between the City of Menasha, a municipal corporation whose principal address is 100 Main Street, Suite 200, Menasha, WI 54952 (the "City") and RG Inspections, LLC, a limited liability company whose principal address is P.O. Box 12, Greenville, WI 54942 ("RG") (collectively, the "Parties").

II. THE RECITALS

WHEREAS the City performs permit inspection services as one of its government functions; and

WHEREAS the City has taken necessary measures and has obtained Delegated Municipal or Appointed Agent Status from the State of Wisconsin for commercial electrical inspections, as required; and,

WHEREAS the City does not believe that the amount of permit inspection services justifies the hiring of a part-time or full-time employee, and is instead seeking RG Inspections, LLC, to perform the services listed in the attached **Exhibit A** (RG Inspections, LLC Scope of Services and Compensation, which commercial electrical inspection services are more particularly described therein and collectively referred to herein as the "Services") for and on behalf of the City; and,

WHEREAS RG is ready, willing and able to perform the Services; and,

WHEREAS Exhibit A reflects the Agreement of the Parties except where it conflicts with this Agreement, in which case this Agreement shall prevail.

NOW THEREFORE, for good and valuable consideration, the sufficiency of which is hereby acknowledged, the City and the RG agree as follows:

III. THE AGREEMENT

1. SCOPE OF SERVICES

- A. RG will perform the Services for the City using qualified professionals licensed* in the State of Wisconsin to perform "work" outlined both in this Agreement and **Exhibit A**. RG will interpret and administer the City's and State's commercial electrical codes. RG will also maintain and file records of all inspections made, work approved, correspondence, and other official actions.
- B. Definitions.
 - i. "RG" shall mean RG Inspections, LLC, and its agents, employees, and authorized representatives.

- ii. "Work" shall mean, collectively, the following services to be performed by RG, commercial electrical projects/inspections as per SPS 316.013 within the City's jurisdictional boundaries (each, a "Project").
- iii. "Project" shall include the following services: (i) coordinate, perform and complete required inspections for permitted electrical projects; (ii) prepare and submit inspections reports back to the City.

*Licens(ing). RG is responsible for, and shall keep in full force and effect, any necessary federal and/or state licensing, and shall comply with all federal and state law regarding any services to be provided pursuant to this Agreement. The City is certified by DSPS to perform Electrical permitting and inspections pursuant to Wisconsin Administrative Code SPS 316.012 (Permits) and SPS 316.013 (Inspections). The City is responsible for any credentials required for the City (Inspection Agency Credential).

2. CHANGES TO SCOPE OF SERVICES

When changes in the defined scope of services are requested by the City, an Amendment to the Agreement may be prepared by the Parties and shall be approved by the Parties prior to performing the work.

3. PAYMENT OF SERVICES

- A. Fees. In consideration of RG providing the Services, the City shall pay RG for the Services performed in accordance with Exhibit A.
- B. Payment Terms. RG shall submit monthly invoices to the City for the Work (or additional services) performed. Payment is due within thirty (30) days of receipt of invoice unless the City requests additional information as described below in Article III., Section 3. B. i. Unpaid invoices shall accrue interest at a rate of 1% per month. Services may be suspended for invoices more than thirty (30) days past due. Fees may be adjusted annually on January 1.
 - i. The City may request additional information, and RG shall provide such information, before approving an invoice. When additional information is requested, the City shall identify specific disputed item(s) and give specific reasons for any request. If additional information is requested, the City will submit payment within thirty (30) days of resolution of the dispute.

4. PERFORMANCE STANDARDS

RG shall use that degree of care, skill, and professionalism ordinarily exercised under similar circumstances by members of the same profession practicing or performing the substantially same or similar services with respect to the category of services being performed. The City acknowledges and agrees that: (i) plan examinations to be provided as part of the Work shall be solely based on the statements, representations, and information in the application, plans and other required and related submissions, including, but not limited to, statements, information and representations as to the location, measurement and/or identification of boundary lines, easements, and elevations; and (ii) inspections to be provided as part of the Work: (a) shall be based only upon visible, observable, and accessible conditions as they exist at the time of inspection; (b) are not designed or intended to predict future conditions; and

(c) do not cover any latent defects, concealed defects, or defects not reasonably observable in the course of or at the time of inspection.

5. TERM AND TERMINATION

A. Term. This Agreement shall become effective on the latest day on which the Agreement is fully executed by both Parties (the "Effective Date"). The initial term of this Agreement shall be twelve (12) months. This Agreement shall automatically renew for successive twelve (12) month periods (each, a "Renewal Term") unless either party gives written notice of nonrenewal to the other party at least thirty (30) days prior to the end of the then-current term (a "Nonrenewal Notice"), in which case the Agreement shall terminate at the end of the then-current term.

B. Termination. Either party may terminate this Agreement, or any part of this Agreement, upon sixty (60) days written notice (a "Termination Notice"), with or without cause, which notice shall set forth the date of termination of this Agreement (the "Termination Date"). RG shall be entitled to receive payment for work completed up to and including the Termination Date, within sixty (60) days of termination. All structures that have had inspections made but services which RG has not completed at the time of termination may be completed through final inspection at the agreed fee rate, if the City so requests, and if finalization does not exceed ninety (90) days.

6. FISCAL NON-APPROPRIATION CLAUSE

Financial obligations of the City after the current fiscal year are contingent upon funds for that purpose being appropriated, budgeted, and otherwise made available in accordance with the rules, regulations, and resolutions of the City, and other applicable law. Upon a failure to appropriate such funds, this Agreement shall be terminated as outlined in Article III., Section 5. B.

7. CITY'S OBLIGATIONS

The City shall timely provide all data, information, plans, specifications, municipal forms, structural calculations, records, and all other documentation reasonably required by RG to perform Services. The City shall arrange for access to and make provisions for RG to enter upon public and private property as may be required for RG's performance of Services per this Agreement.

8. STATUS OF RG AS INDEPENDENT CONTRACTOR

RG is an independent contractor, and neither RG, nor any employees or agent thereof, shall be deemed for any reason to be an employee of the City. RG shall not hold itself out as an employee of the City. As RG is an independent contractor, the City shall have no liability or responsibility for the direct payment of salaries, wages, payroll taxes, or any and all other forms or types of compensation or benefits to any personnel performing services for the City under this Agreement. RG shall be responsible for all compensation, benefits, insurance and employee related rights of any person providing Services hereunder during the course of or arising or accruing as a result of any employment, whether past or present, with RG, as well as all legal costs including attorney's fees incurred in the defense or any conflict or legal action resulting from such employment or related to the corporate amenities of such employment.

9. ASSIGNMENT

Neither party shall assign all or part of its rights, duties, obligations, responsibilities or benefits set forth in this Agreement to another entity without the written approval of both Parties. RG is permitted to subcontract portions of the Services provided that RG give the City prior written notice of the persons or entities with which RG has subcontracted, and the City grants written approval of such subcontracting. RG remains vicariously responsible for any subcontractor's performance or failure to perform. Subcontractors will be subject to the same terms, conditions, rights and responsibilities of RG under this Agreement. Incorporation by reference, and application of all of this Agreement's terms shall be included in any approved subconsultant agreement.

10. INSURANCE

RG will insure, and will require each subcontractor to insure, as indicated, against the following risks to the extent stated below.

- A. Commercial General Liability. RG shall procure and maintain during the life of this Agreement, Commercial General Liability insurance, including, but not limited to bodily injury, property damage, personal injury, and products and completed operations (unless determined to be inapplicable by the City's Risk Manager) in an amount not less than One Million Dollars (\$1,000,000) per occurrence and Two Million Dollars (\$2,000,000) aggregate. This policy shall also provide contractual liability in the same amount. **RG's coverage shall be primary and list the City of Menasha, its officers, officials, agents, and employees, as Additional Insureds.** RG shall require all subcontractors under this Agreement (if any) to procure and maintain insurance meeting the criteria within, applying on a primary basis and listing the City of Menasha, its officers, officials, agents, and employees, as Additional Insureds.
- B. Automobile Liability. One Million Dollars (\$1,000,000) for bodily injury and property damage per occurrence limit covering all vehicles to be used in relationship to the Agreement.
- C. Worker's Compensation. Amounts as required by law plus Employer's Liability of at least One Hundred Thousand Dollars (\$100,000) Each Accident, One Hundred Thousand Dollars (\$100,000) Disease – Each Employee, and Five Hundred Thousand Dollars (\$500,000) Disease – Policy Limit.
- D. Professional Liability. Not less than One Million Dollars (\$1,000,000) each claim and Two Million Dollars (\$2,000,000) general aggregate. If such policy is a "claims made" policy, all renewals thereof during the life of the Agreement shall include "prior acts coverage" covering at all times all claims made with respect to RG's work performed under the Agreement. This Professional Liability Coverage must be kept in force for a period of six (6) years after the Services have been accepted by the City.
- E. Umbrella Liability. Five Million Dollars (\$5,000,000) for bodily injury, personal injury and property damage per occurrence in excess of coverage carried for Employer's Liability, Commercial General Liability, and Automobile Liability.
- F. The above-required insurance is to be placed with insurers acceptable to the City and who have an A.M. best rating of no less than A- (A minus) and a Financial Category rating of no less than VII. RG may be required to provide the City with Certificates of Insurance (COI) and Additional Insured endorsements. RG shall give the City thirty (30) days advance written notice of cancellation, non-renewal, or material changes to any of the above-required policies during the term of the Agreement.

- G. Primary and Non-Contributory Requirement. All insurance must be primary and non-contributory to any insurance or self-insurance carried by the City.
- H. All insurance shall be in full force and effect prior to commencing work and shall remain in full force and effect until the entire job or Services are completed or the length of time specified in this Agreement.

11. THIRD PARTY RELIANCE

This Agreement is intended for the mutual benefit of the parties hereto and no third-party rights are intended or implied.

12. LIMITATION OF LIABILITY

The City may independently exercise its other rights and remedies under this Agreement, at law or equity. RG is acting as the agent of the City in discharging inspection duties, and when acting within the scope of and in good faith in the discharge of its duties, shall not thereby render itself liable personally and is, to the maximum extent permitted by law, relieved of all liability for any damages that may accrue to persons or property by reason of any act or omission in the discharge of its duties. Any suit brought against RG because of the acts or omissions performed by it in the enforcement of and provisions of the Municipal Building Code shall be defended by the City until final termination of the proceedings. The City shall be entitled to all defenses and municipal immunities that are, or would be, available to the City if the same services were provided by City Employees.

No provision contained in this Agreement is intended to waive or estop the City or its insurer to rely upon the limitations, defenses, and immunities within Sections 345.05, 893.80 and 893.83 Wis. Stats. To the extent indemnification is available and enforceable, Municipality and/or its insurer shall not be liable in indemnity, contribution or otherwise for an amount greater than the limits of liability of municipal claims established under Wisconsin law.

13. OWNERSHIP OF DOCUMENTS AND COMPLIANCE WITH PUBLIC RECORDS LAW

The City shall retain ownership of all work product and deliverables created by RG pursuant to this Agreement. All records, documents, notes, data, and other materials required for or resulting from the performance of the Services hereunder shall not be used by RG for any purpose other than the performance of the Services hereunder without the express prior written consent of the City. All such records, documents, notes, data, and other materials, shall become the exclusive property of the City when RG has been compensated for the same as set forth herein, and the City shall thereafter retain sole and exclusive rights to receive and use such materials in such manner and for such purposes as determined by it. If this Agreement expires or is terminated for any reason, all records, documents, notes, data, and other materials, maintained or stored by RG pertaining to the City shall be exported to and become the property of the City.

RG understands and acknowledges that the City is subject to the Public Records Law pursuant to Chapter 19 of the Wisconsin Statutes. As such, RG agrees to retain all records as defined by Section 19.35(2) of the Wisconsin Statutes applicable to this Agreement for a period of not less than seven (7) years. RG further agrees to assist the City in complying with any public records requests that are received pertaining to the Agreement. The City and its duly authorized representatives shall have access to any books, documents, papers and records of

RG that are related to this Agreement for the purposes of audit or examination, other than RG's financial records, and may make excerpts and transcriptions of the same.

14. SEVERABILITY

If any part, covenant, term or provision of this Agreement shall be held to be invalid or unenforceable for any reason, the remaining parts, covenants, terms or provisions of the Agreement shall be valid to the fullest extent permitted by law.

15. DISCRIMINATION & ADA COMPLIANCE

RG will not discriminate against any employee or applicant for employment because of race, color, religion, age, sex, disability, national origin, or any other protected class. Such action shall include but not be limited to the following: employment, upgrading, demotion or transfer, recruitment or recruitment advertising, layoff or termination, rates of pay or other forms of compensation, and selection for training, including apprenticeship. RG agrees to post, in conspicuous places available to employees and applicants for employment, notice to be provided by an agency of the federal government, setting forth the provisions of the Equal Opportunity Law.

RG shall comply with the appropriate provision of the Americans with Disabilities Act (the "ADA"), as enacted and as from time to time amended, and any other applicable federal and State of Wisconsin Law or regulations.

16. NOTICES

Any Notice under this Agreement shall be in writing and shall be deemed sufficient when directly present or sent pre-paid, first-class United States Mail, or emailed and/or addressed as follows:

If to the City:	If to RG:
Andrew Dane 100 Main St, Suite 200 Menasha, WI 54952 adane@menashawi.gov	Attn: Ryan Geiger RG Inspections, LLC PO Box 12 Greenville, WI 54942 RGeiger@Rginspectionsllc.com

17. DISPUTE RESOLUTION

In the event a dispute arises out of or related to this Agreement, or the breach thereof, and if said dispute cannot be settled through negotiation, the Parties agree first to try in good faith to settle the dispute through mediation, before resorting to litigation.

18. GOVERNING LAW AND FORUM SELECTION

This Agreement shall be construed under and governed by the Laws of the State of Wisconsin and all Services to be provided will be provided in accordance with applicable federal, local state, and local municipal law. For any suit, claim or other dispute relating to this Agreement that cannot be mutually resolved, the venue shall be Winnebago County Circuit Court within the State of Wisconsin and the parties agree to submit themselves to the jurisdiction of said court, to the exclusion of any other judicial district that may have jurisdiction over such dispute according to any law.

19. ENTIRETY OF AGREEMENT

This Agreement, along with any attached exhibits, constitutes the complete, entire and final agreement of the Parties hereto with respect to the subject matter hereof, and shall supersede any and all previous communications, representations, whether oral or written, with respect to the subject matter hereof.

20. AUTHORITY

RG represents that it has the authority to enter into this Agreement. If RG is not an individual, the person signing on behalf of RG represents and warrants that he or she has been duly authorized to bind RG and sign this Agreement on RG's behalf.

21. DESIGNATED REPRESENTATIVES

- A. The City designates Andrew Dane, Community Development Director for the City of Menasha, as the Designated Representative who shall administer this Agreement.
Address: 100 Main Street, Ste 200, Menasha, WI 54952
Telephone: 920-967-3651
Email: adane@menashawi.gov
- B. RG designates Ryan Geiger, RG's Registered Agent, as their Designated Representative who shall administer this Agreement.
Address: PO Box 12, Greenville, WI 54942
Telephone: 920-419-2063
Email: RGeiger@rginspectionsllc.com

22. COUNTERPARTS AND COPIES

This Agreement and any amendments may be executed in one or more counterparts, each of which shall be deemed an original, but all of which shall constitute one and the same instrument. For the purposes of executing this Agreement, scanned signatures shall be as valid as the original.

[Signature Page Follows on Next Page]

IN WITNESS HEREOF, the undersigned have caused this Agreement to be executed in their respective names on the dates hereinafter enumerated.

CITY: CITY OF MENASHA

Authorized

Signature: _____

Printed Name: Austin Hammond

Title: Mayor

Date: _____

RG: RG INSPECTIONS, LLC

Authorized

Signature: _____

Printed Name: Ryan Geiger

Title: Registered Agent

Date: _____

CITY: CITY OF MENASHA

Attestation

Signature: _____

Printed Name: Kaija Snyder

Title: City Clerk

Date: _____

RG: RG INSPECTIONS, LLC

Attestation

Signature: _____

Printed Name:

Title:

Date: _____

EXHIBIT A – SCOPE OF SERVICES AND COMPENSATION

Scope of Services

RG will provide Commercial Electrical Inspection Services to the City of Menasha.

Definitions:

1. “RG” shall mean RG Inspections, LLC, and its agents, employees, and authorized representatives.
2. “Services” shall mean, collectively, the following services to be performed by RG, commercial electrical projects/inspections as per SPS 316.013 within the City’s jurisdictional boundaries (each, a “Project”).
3. “Project” shall include the following services: (i) coordinate, perform and complete required inspections for permitted electrical projects; (ii) prepare and submit inspections reports back to the City.

Performance of services shall include the following.

1. Interpret and administer the City’s and State’s commercial electrical codes.
2. Maintain and file records of all inspections made, work approved, and other official actions.

Additional Services

Additional Services not included in this project include:

1. Attending City of Menasha meetings as requested to update the City on various permits, project summaries of work, etc.
2. Attendance for designated office hours.
3. Commercial Electrical Permit Inspections using approved fee schedule.
4. Any other requested inspections.
5. Transferring commercial electrical inspection delegations and maintaining yearly delegations with the State.

Hourly Rates for Additional Services

Additional Services shall be approved in advance by the City’s Community Development Director via email or telephone and will be billed on a time and expense basis.

\$115/hour + Mileage/Expenses

Compensation

RG’s commercial electrical inspection services compensation shall be an individual lump sum payment for each commercial electrical inspection permit. The individual lump sum shall be based on 90% of the permit fee secured by the City with a \$250 minimum fee. Fees shall be based on the current fee schedule and any reductions/alterations to the fee schedule based on City agreements with the business owner, developer’s agreements, etc. shall not apply. Payments to RG shall be monthly and shall include the physical address of the inspection and description of service provided.



MEMORANDUM

DATE December 9, 2025
TO Administration Committee Members
FROM Andrew Dane, Community Development Director
RE Professional Services Agreement with Toole Design Group for Comprehensive Planning Services

Background

The City issued an RFQ to solicit bids for comprehensive planning services related to transportation planning in support of the City’s Comprehensive Plan update.

City staff elected Toole Design Group as the preferred contractor based on qualifications and work product.

The attached Professional Services Agreement (PSA) with Toole Design Group will provide the City with Comprehensive Planning Services.

Toole Design Group’s contract is a lump sum fee of \$15,000.

Recommendation

Staff recommend the Administration Committee approve the professional service agreement between the City of Menasha and Toole Design Group for Comprehensive Planning Services.

PROFESSIONAL SERVICES AGREEMENT

This Professional Services Agreement (hereinafter, "Agreement"), made on the ___ day of _____, 2025, by and between the City of Menasha, a Wisconsin Municipal Corporation with its principal office at 100 Main St. Ste 200, Menasha, Wisconsin, 54952 (hereinafter "City"), and Toole Design Group, LLC, a Foreign LLC registered in Wisconsin, with its principal office at 8484 Georgia Avenue, Suite 800, Silver Spring, MD 20910, (hereinafter, "Consultant").

WITNESSETH

The City and the Consultant, for the consideration hereinafter named, enter into the following Professional Services Agreement for Planning and Design Services for the Menasha Bike Feasibility Study Project (hereinafter, "Project").

ARTICLE I. PROJECT MANAGER

A. Assignment of Project Manager. Consultant shall assign the following individual to manage the Project described in this Agreement:

Shaun Murphy-Lopez, Project Manager

B. Changes in the Project. The City shall have the right to approve or disapprove of any proposed change from the individual named as Project Manager. The City shall be provided with a resume or other information for any proposed substitute and shall be given the opportunity to interview that person prior to any proposed change.

ARTICLE II. CITY REPRESENTATIVE

The City shall assign the following individual to manage the Project described in this Agreement:

Andrew Dane – Community Development Director

ARTICLE III. SCOPE OF WORK

Consultant shall provide the services described in Consultant's *August 25, 2025, Memorandum Re: Draft Scope of Work and Schedule* (attached and incorporated herein as Exhibit A). The City may make or approve changes within the general Scope of Services in this Agreement. If such changes affect Consultant's cost of or time required for performance of the services, an equitable adjustment will be made through an amendment to this Agreement.

All reports, drawings, specifications, computer files, field data, notes, concept plans, sketches, and other documents and instruments prepared by Consultant as instruments of service shall become property of the City upon payment for those documents by the City to Consultant, and shall remain the property of the City. Ownership shall not extend to Consultant's underlying means and methods used to create work product. Additionally, any preexisting intellectual property contained within Consultant's deliverables thereto belonging to Consultant shall remain the property of Consultant unless otherwise indicated in the scope of services.

ARTICLE IV. STANDARD OF CARE

The standard of care applicable to Consultant's services will be the degree of skill and diligence normally employed by professional consultants or consultants performing the same or similar services at the time said services are performed. Consultant will re-perform any services not meeting this standard without additional compensation.

ARTICLE V. OPINIONS OF COST, FINANCIAL CONSIDERATIONS, AND SCHEDULES

In providing opinions of cost, financial analyses, economic feasibility projections, and schedules for the Project, Consultant has no control over cost or price of labor and materials; unknown or latent conditions of existing equipment or structures that may affect operation or maintenance costs; competitive bidding procedures and market conditions; time or quality of performance by operating personnel or third parties; and other economic and operational factors that may materially affect the ultimate project cost or schedule. Therefore, it is understood between the parties that Consultant makes no warranty as to the City's actual project costs, financial aspects, economic feasibility, or schedules will not vary from Consultant's opinions, analyses, projections, or estimates.

ARTICLE VI. CITY RESPONSIBILITIES

The City shall furnish, at Consultant's request, such information as is needed by the Consultant to aid in the progress of the Project, providing it is reasonably obtainable from City records. The Consultant shall be able to reasonably rely on all information furnished by the City.

To prevent any unreasonable delay in Consultant's work, the City will examine all reports and other documents and will make any authorizations necessary to proceed with work within a reasonable time period.

ARTICLE VII. CITY'S INSURANCE

The City will maintain property insurance on all pre-existing physical facilities associated in any way with the Project.

ARTICLE VIII. TIME OF COMPLETION

The work to be performed under this Agreement shall be commenced and the work completed within the time limits as agreed upon in Exhibit A.

Consultant shall perform the services under this Agreement with reasonable diligence and expediency consistent with sound professional practices. The City agrees Consultant is not responsible for damages arising directly or indirectly from any delays for causes beyond Consultant's control. For the purposes of this Agreement, such causes include, but are not limited to, strikes or other labor disputes, severe weather disruptions or other natural disasters, failure of performance by the City, or discovery of any hazardous substances or differing site conditions. If the delays resulting from any such causes increase the time required by Consultant to perform its services in an orderly and efficient manner, Consultant shall be entitled to an equitable adjustment in schedule.

ARTICLE IX. COMPONENT PARTS OF THE AGREEMENT

This Agreement consists of the following component parts, all of which are as fully a part of this Agreement as if herein set out verbatim, or if not attached, as if hereto attached:

1. This Instrument
2. Exhibit A attached hereto

In the event any provision of the above component parts of this Agreement conflicts with any provision in any other of the component parts, the provision in the component part first enumerated above shall govern over any other component part which follows it numerically except as may be otherwise specifically stated.

ARTICLE X. PAYMENT

A. The Agreement Sum. The City shall pay to Consultant for the performance of the Agreement the total sum as set forth below, adjusted by any changes hereafter mutually agreed upon in writing by the parties hereto:

- Lump sum fee of \$15,000.00 (Fifteen Thousand Dollars).

B. Method of Payment. Consultant shall submit itemized monthly statements for services. The City shall pay Consultant within thirty (30) calendar days after receipt of such statement. If any statement amount is disputed, the City may withhold payment of such amount and shall provide to Consultant a statement as to the reason(s) for withholding payment. Should the City fail to make timely payment of undisputed amounts, Consultant reserves the right to stop work until payment is received.

C. Additional Costs. Costs for additional services shall be negotiated and set forth in a written amendment to this Agreement executed by both parties prior to proceeding with the work covered under the subject amendment.

D. Indirect Costs. Indirect costs such as computer time, printing, copying, cell phone charges, telephone charges, and any equipment rental shall be considered overhead and shall not be invoiced separately by Consultant.

E. Expenses. Expenses may be billed with up to a maximum of ten percent (10%) mark-up. All invoices with expenses shall include supporting documentation of the expense. Failure to include the supporting documentation will result in the reduction of payments by the amount of those expense(s) not including documentation.

ARTICLE XI. STANDARD PROVISIONS

Consultant agrees that, in all hiring or employment made possible by or resulting from this Agreement, there will not be any discrimination against any employee or applicant for employment because of race, color, religion, marital status, age, color, sex, gender identity, handicap, national origin or ancestry, income level or source of income, arrest record or conviction record, less than honorable discharge, physical appearance, sexual orientation, political benefits, or student status.

ARTICLE XII. HOLD HARMLESS

Consultant covenants and agrees to protect and hold the City of Menasha harmless against actions, claims, and demands to the proportionate extent caused by the intentionally wrongful or negligent acts of Consultant, their agents or assigns, their employees, or their subcontractors related to the performance of this Agreement or caused from any violation of any law or administrative regulation, and shall indemnify the City for all sums including court costs, reasonable attorney fees, and damages which the City may be obliged or adjudged to pay on any such claims or demands upon the City's written demand for indemnification or refund for those actions, claim, and demands caused by intentional or negligent acts as specified in this Paragraph.

Subject to any limitations contained in Sec. 893.80 and any similar statute of the Wisconsin Statutes, the City further agrees to hold Consultant harmless from any and all liability, including claims, demands, losses, costs, damages, and expenses of every kind and description (including death), or damages to person or property arising out of re-use of the documents without consent where such liability is founded upon or grows out of the acts or omission of any of the officers, employees, or agents of the City of Menasha while acting within the scope of their employment.

ARTICLE XIII. INSURANCE

Consultant will insure, and will require each subcontractor to insure, as indicated, against the following risks to the extent stated below.

- A. Commercial General Liability. Consultant shall procure and maintain during the life of this Agreement, Commercial General Liability insurance, including, but not limited to bodily injury, property damage, personal injury, and products and completed operations (unless determined to be inapplicable by the Risk Manager) in an amount not less than One Million Dollars (\$1,000,000) per occurrence. This policy shall also provide contractual liability in the same amount. Consultant's coverage shall be primary and list the City of Menasha, its officers, officials, agents and employees as additional insureds. Consultant shall require all subcontractors under this Agreement (if any) to procure and maintain insurance meeting the criteria within, applying on a primary basis and listing the City of Menasha, its officers, officials, agents and employees as additional insureds.
- B. Automobile Liability. One Million Dollars (\$1,000,000) for bodily injury and property damage per occurrence limit covering all vehicles to be used in relationship to the Agreement.
- C. Worker's Compensation. Amounts as required by law plus Employer's Liability limits of at least One Hundred Thousand (\$100,000) Each Accident, One Hundred Thousand (\$100,000) Disease – Each Employee, and Five Hundred Thousand (\$500,000) Disease – Policy Limit.
- D. Professional Liability. Not less than One Million (\$1,000,000). If such policy is a "claims made" policy, all renewals thereof during the life of the Agreement shall include "prior acts coverage" covering at all times all claims made with respect to Consultant's work performed under the Agreement. This Professional Liability coverage must be kept in force for a period of six (6) years after the services have been accepted by the City.

- E. Umbrella Liability. Five Million (\$5,000,000) for bodily injury, personal injury and property damage per occurrence in excess of coverage carried for Employer's Liability, Commercial General Liability and Automobile Liability.
- F. The above-required insurance is to be placed with insurers acceptable to the City and who have an A.M. best rating of no less than A- (A minus) and a Financial Category rating of no less than VII. Consultant may be required to provide the City with certificates of insurance and additional insured endorsement. Consultant shall give the City thirty (30) days advance written notice of cancellation, non-renewal, or material changes to any of the above-required policies during the term of the Agreement.

ARTICLE XIV. TERMINATION

A. For Cause. If Consultant shall fail to fulfill in timely and proper manner any of the obligations under this Agreement, the City shall have the right to terminate this Agreement by written notice to Consultant provided, however, that Consultant has been afforded no less than five (5) business days to cure or substantially begin to cure any failure.. In this event, Consultant shall be entitled to compensation for any satisfactory, usable work completed.

B. For Convenience. Either party may terminate this Agreement at any time by giving written notice no later than ten (10) calendar days before the termination date. If the City terminates under this Paragraph, then Consultant shall be entitled to compensation for any satisfactory work performed to the date of termination.

This document and any specified attachments contain all terms and conditions of the Agreement and any alteration thereto shall be invalid unless made in writing, signed by both parties and incorporated as an amendment to this Agreement.

ARTICLE XV. RE-USE OF PROJECT DOCUMENTS

All reports, drawings, specifications, documents, and other deliverables of Consultant, whether in hard copy or in electronic form, are instruments of service for this Project, whether the Project is completed or not. Subject to individual review, Consultant's reports, drawings, specifications, documents, or other deliverables will generally be considered public records that are available to the public upon request. Neither the City nor Consultant, therefore, has control of these documents once they are disclosed as a public record. It is understood between these two (2) parties, however, that Consultant does not intend to state or imply that the Project documents it creates have any purpose unrelated to the Project. To the extent the City may re-use or reference any part of Consultant's documents or information on unrelated projects, the City agrees to independently verify their applicability for unrelated projects and further agrees the Standard of Care applicable to the documents for this Project will not apply to their re-use or reference in unrelated projects.

ARTICLE XVI. SUSPENSION, DELAY, OR INTERRUPTION OF WORK

The City may suspend, delay, or interrupt the services of Consultant for the convenience of the City. In such event, Consultant's agreement price and schedule shall be equitably adjusted.

ARTICLE XVII. NO THIRD-PARTY BENEFICIARIES

This Agreement gives no rights or benefits to anyone other than the City and Consultant and has no third-party beneficiaries.

ARTICLE XVIII. AUTHORITY

Consultant represents that it has the authority to enter into this Agreement. If Consultant is not an individual, the person signing on behalf of Consultant represents and warrants that he or she has been duly authorized to bind Consultant and sign this Agreement on Consultant's behalf.

[Signatures on Following Page]

In the Presence of:

(Seal of CONSULTANT if a Corporation)

CONSULTANT

By: *Cia Jellicoe*

Director of Operations, Midwestern US
(Specify Title)

By: *RJ Eldridge*
RJ Eldridge (Sep 15, 2025 16:33:17 EDT)

Executive Vice President/COO
(Specify Title)

CITY OF MENASHA

(Witness)

By: _____
Austin Hammond, City of Menasha Mayor

(Witness)

And: _____
Kaija Snyder, City Clerk

APPROVED AS TO FORM:

Margaret J. Struve, City Attorney

I hereby certify that the necessary provisions which have been made to pay the liability which will accrue under this Agreement.

Jennifer Sassman, Finance Director (Comptroller)

MEMORANDUM

November 24, 2025

To: Andrew Dane, James Merten

Organization: City of Menasha

From: Shaun Murphy-Lopez, Tom Natwick

Project: Menasha Bike Feasibility Study

Re: Scope of Work and Schedule

This memorandum provides a draft scope of work and schedule to carry out the Menasha Bike Feasibility Study. We look forward to refining this scope and schedule with the City.

Project Understanding

The City of Menasha and neighboring communities have made major progress implementing a trails network throughout the region. Significant trails have included the Friendship Trail, the Loop the Little Lake Trail, Trestle Trail, trails in Jefferson Park, and a trail along Water Street. Bike lanes have also been installed on streets such as 1st Street, Ahnaip Street, Appleton Road, Broad Street, Depere Street, Plank Road, and Racine Street.

The City now desires to explore the possibility of creating an east-west connection between the Friendship Trail/Loop the Little Lake Trail/Trestle Trail and Jefferson Park, which will eventually connect to High Cliff State Park. This connection may go through Downtown, along the north side of the Menasha Channel, or through Doty Island ([see the map on the following page](#)). The connection needs to be comfortable for all trail users and is likely to be a protected bike lane facility. Up to three east-west route alternatives and their project implementation recommendations need to be identified. Additionally, a planning level cost estimate is needed for future budget programming.

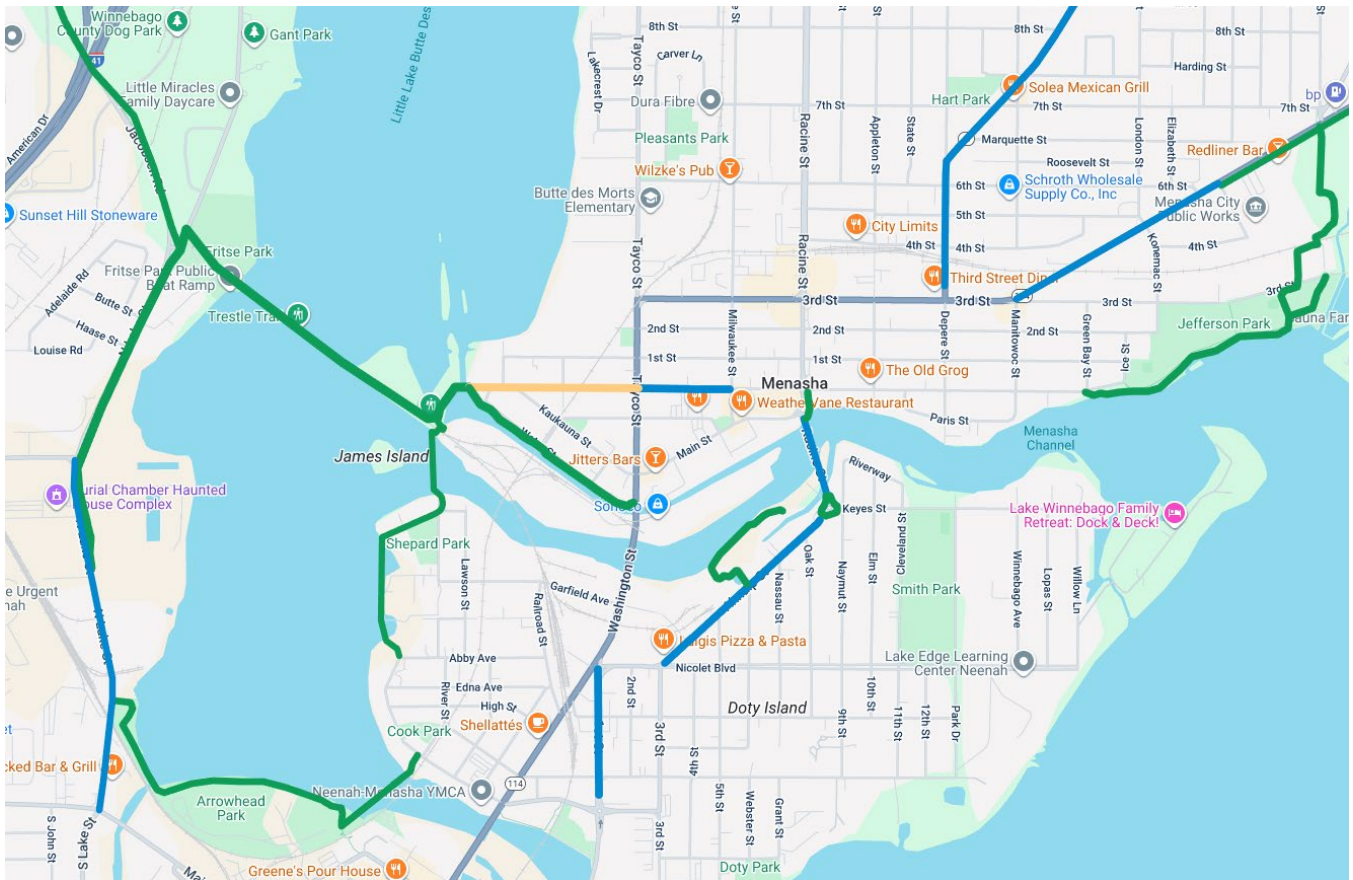

A map of the feasibility study area showing existing trails in green, existing bike lanes in blue, and existing sharrows in yellow.

Scope of Work

Task 1: Project Management

Task 1.1 Monthly Progress Reports

Toole Design will submit Monthly Progress Reports and invoices to the client.

Task 1.2 Conference Calls

Toole Design’s Project Manager, Shaun Murphy-Lopez, will check in with the City’s Project Manager and other staff once a month to monitor the project’s progress and plan for next steps. Members of our team will be available for a limited number of additional conference calls as needed. After each check-in, our team will document, transmit, and implement action items as necessary.

Task 1 Deliverables:

- Monthly Progress Reports
- Monthly Conference Calls (Up to four calls)

Provided by City Staff:

- Review of Monthly Progress Reports
- Participation in Conference Calls

Task 2: Identification of Route Alternatives

Task 2.1 Bicycle Network Map

Toole Design will create a map illustrating the current network for bicycling within the project area. This map may include information such as upcoming bikeway projects, bicycle facility types, the street network, existing parks, and municipal boundaries.

Task 2.2 Route Alternatives

Using the map created in Task 2.1, Toole Design will work with City staff to identify up to three east-west Route Alternatives. Routes may include existing trails, streets with bike lanes, and streets without bicycling facilities.

Task 2 Deliverables:

- Existing Bicycle Network map
- Route Alternatives map

Provided by City Staff:

- Current bicycle facilities and related data in GIS
- Review and comment on maps

Task 3: Project Implementation Recommendations and Cost Estimate

Task 3.1 Project Implementation Recommendations

Using the information gathered in Task 2, Toole Design will generate potential project implementation recommendations for up to 3 alternative routes. Recommendations may include but not be limited to:

- Analysis of available street width
- Connections to existing bicycle facilities and popular destinations
- Future cross section options
- Feasibility
- On-street parking changes
- Phasing
- Solutions to challenging locations (e.g., bridges, intersections, roundabouts)
- Traffic volume analysis
- Upcoming construction projects

Project implementation recommendations will be summarized in approximate 2-page summaries that can be incorporated into the City's Comprehensive Plan.

Task 3.2 Cost Estimate

Based on the Project Implementation Recommendations process, Toole Design will develop a planning level Cost Estimate for the design and construction of Route Alternatives. Estimate will be generated based on retrofitted installations of bikeways – not complete street reconstructions.

Task 3 Deliverables:

- Project Implementation Recommendations memo
- Planning level Cost Estimates for Route Alternatives

Provided by City Staff:

- Review of Project Implementation Recommendations memo
- Review of Cost Estimates

- Recent relevant bid tabulations for the development of bikeways (if available)

Task 4: Public Input

Toole Design will prepare materials for one public input session of the City’s comprehensive planning process, expected to take place on September 24th. The materials will be used to collect viewpoints of the public about their preferred east-west connection between the Loop the Little Lake Trail and Jefferson Park. Toole Design may provide one staff member for an on-site visit, if desired by the City of Menasha.

Task 4 Deliverables:

- Materials for one public input session

Provided by City Staff:

- Review of public input materials

Anticipated Project Schedule

Below is the Toole Design Team’s proposed timeline for the project. Based on our experience working on similar efforts, we anticipate that the project can be substantially completed in approximately five months.

Menasha Bike Feasibility Study						
Task	Description	2025				2026
		September	October	November	December	January
1	Project Management					
1.1	Monthly Progress Reports					
1.3	Conference Calls					
2	Identification of Route Alternatives					
2.1	Bicycle Network Map					
2.2	Route Alternatives					
3	Project Implementation Recommendations and Cost Estimate					
3.1	Project Implementation Recommendations					
3.2	Cost Estimate					
4	Public Input					
4.1	Public Input					

Proposed Fee

Toole Design will complete the scope of work for a lump sum fee of \$15,000.



MEMORANDUM

To: Common Council

From: Director of Parks & Recreation – Megan Sackett/ms

Date: December 29, 2025

RE: Contract for Services with East Central Wisconsin Regional Planning Commission (ECWRPC) for the Comprehensive Outdoor Recreation Plan (CORP) Update

The City's current CORP was last fully updated and adopted in 2020. While the plan continues to provide a strong foundation for parks and recreation planning, periodic updates are necessary to ensure it accurately reflects current conditions, completed projects, community needs, and future priorities. An up-to-date CORP is also required to maintain eligibility for Wisconsin Department of Natural Resources (WDNR) grant programs, including the Knowles-Nelson Stewardship Program and other outdoor recreation funding opportunities.

Since the 2020 update, the City has completed or advanced several park, trail, and facility projects, and additional needs and priorities have emerged. Updating the CORP in 2026 will allow the City to reassess priorities, incorporate updated data and mapping, and ensure continued alignment with broader City planning and capital improvement efforts.

The agenda item is approval of a contract with the East Central Wisconsin Regional Planning Commission (ECWRPC) to complete the 2026 CORP update. ECWRPC also led the City's 2020 CORP update and is familiar with Menasha's park system, community context, and WDNR planning requirements. Their prior experience will provide continuity, efficiency, and consistency in the update process.

Throughout the process, Park Board Board and the community will be given opportunity to provide feedback. Upon completion, the updated CORP will be brought back to the Park Board and Common Council for review and formal adoption.

Recommendation

Park Board recommends to the Common Council approval for the Contract for Services with East Central Wisconsin Regional Planning Commission (ECWRPC) for the Comprehensive Outdoor Recreation Plan (CORP) Update.



**East Central Wisconsin Regional Planning Commission
Scope of Work & Contract for Services for:**

City of Menasha Comprehensive Outdoor Recreation Plan Update

ECWRPC Project Number: 2476-026

09/08/2025

CONTRACT BETWEEN

EAST CENTRAL WISCONSIN REGIONAL PLANNING COMMISSION
(COMMISSION)
AND CITY OF MENASHA, WISCONSIN (CITY)

**FOR PROJECT NUMBER: 2476-026
CITY OF MENASHA COMPREHENSIVE PLAN UPDATE**

This CONTRACT, made and entered into by and between East Central Wisconsin Regional Planning Commission (COMMISSION) and the CITY of Menasha, Wisconsin (CITY), to provide services described in detail herein and is for the purpose of:

The main focus of the Open Space and Recreation program is to improve the quality of life and provide healthy spaces for residents and visitors to recreate. Evidence has shown that parks and open space provide many benefits to a community. These benefits include increased individual health, economic growth, and cleansing of the natural environment through green spaces.

The Commission assists local communities with their Comprehensive Outdoor Recreation Plan (CORP) updates to protect, preserve, and enhance the environment now and for future generations. These plans must be completed every five years to be eligible for Wisconsin Department of Natural Resources Stewardship grants and other funding for improvements. They are critical documents that typically include geography, demographics, current conditions inventory, needs assessments for facilities both today and tomorrow, safe access to parks (audits), goals, objectives, and a five-year action plan for implementation strategy.

The COMMISSION deems it advisable to engage the CITY to provide certain services and has authority to contract for these services as permitted by its Bylaws. The COMMISSION will be compensated by the CITY for services provided under this CONTRACT on the following cost basis:

- a) An ACTUAL COST up to \$16,403.00 to be paid in **quarterly** installments for work completed between **01/01/2026 and 10/31/2026 as outlined in the Scope of Services, Appendix A (see Appendix B, Section III, Item 3 regarding payment).**
- b) The **final invoice** will be submitted once the **final services and materials have been submitted to the** CITY and **both parties are in agreement** the final products have been completed.

The COMMISSION represents it is in compliance with the laws and regulations relating to its profession and signifies its willingness to provide the desired services.

The CITY Representative and billing contact is:

Megan Sackett
CITY of Menasha
920-967-3640
msackett@menashawi.gov

The COMMISSION Representative is:

Joe Stephenson, Senior Planner
East Central Wisconsin Regional Planning Commission
(920) 886-6832
jstephenson@ecwrpc.org

The parties agree to all of the provisions which are annexed and made a part of the CONTRACT consisting of ten pages, including cover sheets, Appendix A (Scope of Services), and Appendix B (East Central's Locally Funded Contract).

For the CITY of Menasha

For the COMMISSION

By:

By:

Melissa A Kraemer Badtke

Name:
Title:

Melissa A. Kraemer Badtke
Executive Director

Click or tap to enter a date.

11/5/2025
Click or tap to enter a date.

**APPENDIX A:
SCOPE OF SERVICES FOR
PROJECT NUMBER: 2476-026**

Scope of Services:

Project Overview

The East Central Wisconsin Regional Planning Commission (ECWRPC) will work with the City of Menasha to prepare an updated Comprehensive Outdoor Recreation Plan (CORP) for 2026. This plan ensures the City remains eligible for Wisconsin Department of Natural Resources (WDNR) Stewardship grants and other funding opportunities. The update will evaluate current conditions, community needs, and establish a five-year action plan for the City's park and recreation system

Tasks & Deliverables

1. Project Management

- Provide overall coordination and oversight of CORP development.
- Maintain communication with City staff and the Parks Committee.
- Submit quarterly progress reports and invoices.

2. Coordination with Staff and Parks Committee

- Regular meetings to review progress, data, and draft materials.
- Presentation of findings, draft recommendations, and final plan for input and approval.

3. Inventory and Park Audits

- Review existing park facilities, open spaces, and recreational amenities.
- Conduct park audits to assess accessibility, safety, and conditions.

4. Community Engagement

- Conduct one in-person kick-off meeting.
- Facilitate one visioning session and one pop-up event to gather community input.
- Analyze community survey data (survey to be completed prior to project).
- Note: The CITY has already conducted a survey and ECWRPC will use the data from that survey to update the CORP.

5. Needs Analysis & Level of Service (LOS)

- Compile demographic and background data.
- Evaluate existing facilities and services.
- Develop level of service analysis by park type to identify gaps and needs.

6. Vision and Goal Development

- Prepare goals and objectives based on data and community input.
- Identify key issues and opportunities.

7. Concept Plan, Strategies, and Recommendations

- Identify priority projects, improvements, and enhancements.
- Develop draft recommendations and action plans
- Review existing and potential funding sources.
- Identify future facilities and alternative funding options.
- Prioritize projects for phased implementation.

8. Plan Implementation

- Finalize draft maps and recommendations.
- Adjust implementation strategies based on staff and committee feedback.

9. Plan Review & Adoption

- Present the draft plan to Parks Committee or Common Council.
- Finalize the plan and maps.
- Support City staff in adoption process, including public presentation

Comprehensive Outdoor Recreation Plan (CORP)	2026									
	Jan	Feb	Mar	Apr	May	June	July	Aug	Sept	Oct
Task Description										
Project Management										
Coordinate with Staff and Parks Committee										
Inventory and Park Audits										
In-Person Kick Off Meeting										
Community Engagement: Public Engagement and Visioning										
Visioning Session and Pop Up Event										
Analysis of Survey Data										
Needs Analysis and Level of Service: Background and Evaluate Existing Conditions										
Compile Demographic and Background Data										
Review Park Inventory Analysis										
Develop level of service analysis by park type										
Vision and Goal Development										
Draft Vision Statement										
Draft Goals and Objectives										
Identify Key Issues and Opportunities										
Concept Plan, Strategies, and Recommendations: Identify Priority Projects, Improvements, and Enhancements										
Check-in to Review Draft Recommendations/Action Plan										
Review Draft Concept Maps										
Identification of Future Facilities										
Review Existing Funding										
Identify Alternative Funding Options										
Prioritize Projects										
Plan Implementation: Final Adjustments										
Draft Maps Completed										
Final Maps Completed										
Plan Review and Adoption: Plan Completion										
Final Presentation										
Final Draft Plan Development & Review										
Final Plan Review and Adoption										

Parks Cmte Mtng	ECWRPC Task	Public Engagement Session
-----------------	-------------	---------------------------

Task Description	Planning Staff				GIS Staff				Cost Expenses					Total Project Costs
	Project Mgr Hrs	Planner Hrs	Total Hrs	Total Cost	GIS Manager Hrs	GIS Analyst Hrs	Total Hrs	Total Cost	Miles	Mileage Cost	Meals	Contingency	Total Other Expenses	
Project Management	7	16	23	\$2,092.00	2	5	7	\$599.00	0	\$ -			\$0.00	\$2,691.00
Community Engagement (Survey is complete)(1 visioning session and 1 pop up event)	3	6	9	\$822.00	2	0	2	\$204.00	4	\$ 2.80			\$2.80	\$1,028.80
Needs Analysis & Level of Service (LOS)	8	12	20	\$1,844.00	2	12	14	\$1,152.00	0	\$ -			\$0.00	\$2,996.00
Development of the Vision & Goals	3	12	15	\$1,344.00				\$0.00		\$ -			\$0.00	\$1,344.00
Concept Plan, Strategies & Recommendations	5	20	25	\$2,240.00	1	26	27	\$2,156.00		\$ -			\$0.00	\$4,396.00
Plan Implementation	5	8	13	\$1,196.00				\$0.00		\$ -			\$0.00	\$1,196.00
Plan Review & Adoption	5	6	11	\$1,022.00		3	3	\$237.00	2	\$ 1.40			\$1.40	\$1,260.40
												\$1,490.80	\$1,490.80	\$1,490.80
Total Project Costs	36	80	116	\$10,560.00	7	46	53	\$4,348.00	6	\$4.20	0	\$1,490.80	\$1,495.00	\$16,403.00

**APPENDIX B:
EAST CENTRAL'S LOCALLY FUNDED CONTRACT**

I. Scope of Services

1. The services under this CONTRACT shall consist of performing all work necessary or incidental to accomplish this PROJECT as defined in Appendix A.
2. The COMMISSION, within 30 days of the approval of the final document by the CITY Council, will produce and deliver the following materials in order to satisfy the contract:
 - 1) A full Adobe Acrobat (.pdf) version of the plan document with maps and a separate version with maps separated out for web posting;
 - 2) 1 set of files and data used – plan chapters, tables, pictures, etc.
 - 3) 1 set of files of all maps utilized in the plan document.
3. Additional copies of the above materials can be produced in excess of what is noted above and a separate cost estimate can be provided if requested by the CITY.
4. The COMMISSION shall furnish all services and labor necessary to conduct and complete the services, and shall furnish all materials, equipment, supplies, and incidentals other than those designated to be furnished by the CITY.
5. The services shall comply with applicable state and federal laws and regulations consistent with the funding for this PROJECT.
6. The COMMISSION shall from time to time during the progress of the services confer with the CITY and shall prepare and present such information, studies, and reports as may be necessary or as may be requested by the CITY to enable it to reasonably pass judgment on the features of the services. The COMMISSION shall make such changes, amendments, or revisions in the detail of the services as may be required by the CITY. The COMMISSION is not relieved from the responsibility for continuing adherence to generally accepted standards of the profession by CITY required changes in the detail of the services.
7. Meetings may be scheduled at the request of the COMMISSION or the CITY for the purpose of discussing and reviewing the services under this CONTRACT. Meeting schedules are to be coordinated with the COMMISSION Representative.

II. Prosecution and Progress

A. General

1. Services under this CONTRACT shall commence upon written order from the CITY to the COMMISSION, which order will constitute authorization to proceed.
2. The COMMISSION shall complete the services under this CONTRACT within the time for completion specified. Services by the COMMISSION shall proceed continuously and expeditiously. The time for completion shall not be extended because of any delay attributable to the COMMISSION but may be extended by the CITY in the event of a delay attributable to the CITY or because of unavoidable delays caused by an act of God, war, governmental actions or other conditions beyond the control of the CITY.
3. The COMMISSION shall notify the CITY in writing when the services have been completed. Upon the CITY's subsequent determination that the services have satisfactorily been completed, the CITY will provide written notification to the COMMISSION acknowledging the formal acceptance of the completed services.

B. Delays and Extensions

1. Delays in completing the services within the time provided for completion for reasons not attributable to the COMMISSION may constitute justification for additional compensation to the extent of documentable increases in costs as a result thereof. Failure of the COMMISSION to submit a formal written request for a time extension and additional compensation prior to the expiration of the CONTRACT time shall constitute a basis for denying any cost adjustments for reasons of delay.

2. It is the expectation that the COMMISSION and CITY will meet deadlines and deliverables as mutually agreed upon.
3. Delays grossly affecting the completion of the services attributable or caused by one of the parties hereto shall be considered as cause for the termination of the CONTRACT by the other party.
4. A request for extension of the CONTRACT by the COMMISSION must be submitted to the CITY prior to October, 1st, 2026 which is 30 days before the original CONTRACT completion date of October 31st, 2026.
5. Time is of the essence with regard to the delivery of all services under this CONTRACT.

C. Termination

1. The COMMISSION reserves the right to terminate all or part of this CONTRACT at any time upon not less than ten days' written notice to the CITY.
2. In the event the CONTRACT is terminated by the CITY without fault on the part of the COMMISSION or by the COMMISSION under II.B(2) above, the COMMISSION shall be paid for the services rendered an amount bearing the same ratio to the total CONTRACT prices as the amount of services completed or partially completed and delivered to the CITY bears the total amount of services provided for herein, as determined by mutual agreement between the COMMISSION and the CITY as the CONTRACT amendment.
3. In the event the services of the COMMISSION are terminated by the CITY for fault on the part of the COMMISSION, the COMMISSION shall be paid a reasonable value of the services rendered and delivered to the CITY up to the time of termination. The value of the services will be determined by the COMMISSION.

D. Subletting or Assignment of Contract

1. The COMMISSION shall not sublet or assign any part of this CONTRACT without prior written approval of the CITY unless previously authorized as part of the approved scope of services contained in Appendix A.
2. When the COMMISSION is authorized to sublet or assign a portion of the services, the COMMISSION shall perform services amounting to at least one half of the original CONTRACT amount.
3. Consent to assign, sublet, or otherwise dispose of any portion of the CONTRACT shall not be construed to relieve the COMMISSION of any responsibility for the fulfillment of the CONTRACT.
4. When the COMMISSION subcontracts a portion of the services, the subcontract shall provide for the performance of the services to the full scope as contemplated in this CONTRACT and to the same standards and concept as if performed by the COMMISSION.
5. No subcontracting and assignment of any services under this CONTRACT shall state, imply, intend, or be construed to limit the legal liability of the COMMISSION.

III. Basis of Payment

1. The COMMISSION will be paid by the CITY for the completed and approved services rendered under this CONTRACT on the basis and at the CONTRACT price set forth elsewhere in this CONTRACT. Such payment shall be full compensation for services rendered and for all labor, materials and supplies, equipment, and incidentals necessary to complete the services. Compensation in excess of the total CONTRACT amount will not be allowed unless justified and authorized by an approved written CONTRACT amendment. Compensation for improper performance by the COMMISSION will not be allowed. No payment shall be construed as CITY acceptance of unsatisfactory or defective services or improper materials.
2. Reimbursement for costs will be limited to those which are allowable by COMMISSION policy.
3. The CITY has the equitable right to set off against any sum due and payable to the COMMISSION under this CONTRACT any amount the CITY determines the COMMISSION owes the CITY, whether arising under this CONTRACT or under any other CONTRACT or otherwise.
4. If, in the COMMISSION's opinion, orders or instructions given by the CITY would require the discarding or redoing of services which were based upon earlier direction or approvals, or instruction given by the CITY would involve services not within the scope of services, the COMMISSION must notify the CITY in

writing if it desires extra compensation or a time extension. The CITY will review the COMMISSION's submittal and, if acceptable, approve a CONTRACT amendment.

5. Quarterly, the COMMISSION will provide to the CITY contact the following items.
 - a. Letterhead expressing the balance due
 - b. Invoice
 - c. Progress Report: Summary of services provided and progress through the projected timeline.
6. All invoices for payment shall be submitted to:

Megan Sackett
CITY of Menasha
920-967-3640
msackett@menashawi.gov

7. The final invoice shall be submitted to the CITY within 30 days of completion of the services. Final payment of any balance due the COMMISSION will be made within 30 days upon its verification by the CITY, upon completion of the required services, and upon receipt of documents or materials required to be returned or furnished to the CITY. Should this CONTRACT include more than one PROJECT, separate invoices shall be submitted for each individual PROJECT.

IV. Miscellaneous Provisions

A. Ownership of Documents

1. All materials, guides, written instructions, plans, documents, correspondence, forms, computer files, databases, electronic mail messages, work product, or other information of any type created by the COMMISSION under this CONTRACT are works created for hire and are the property of the COMMISSION and the CITY unless specifically identified as material or data that is proprietary in nature. All project documents provided to the CITY by the COMMISSION or by any third party which pertains to this CONTRACT are property of the CITY and the COMMISSION.
2. Upon demand by the CITY, all project documents (excluding information that may be proprietary in nature) shall be delivered to the CITY. Project documents may be used without restriction by the CITY and the COMMISSION for any purpose. Any such use shall be without compensation or liability to the COMMISSION. The CITY and the COMMISSION have all rights to copyright or otherwise protect the project documents which are the property of the CITY and the COMMISSION.
3. Implementation of the Plan is solely the CITY's responsibility.

V. Contingent Fees

1. The COMMISSION warrants that it has not employed or retained any company or person (other than identified in the Scope of Services) other than a bona fide employee working solely for the COMMISSION to solicit or secure this CONTRACT and that the COMMISSION has not paid or agreed to pay any company or person, other than a bona fide employee working solely for the COMMISSION, any fee, commission, percentage, brokerage fee, gift or any other consideration, contingent upon or resulting from the award or making of this CONTRACT. For breach or violation of this warranty the CITY shall have the right to terminate this CONTRACT without liability, or in its discretion to deduct from the agreement price or consideration, otherwise recover, the full amount of such fee, commission, percentage, brokerage fee, gift or contingent fee.

VI. Legal Relations

1. The COMMISSION shall become familiar with, and shall at all times observe and comply with all applicable federal, state, and local laws, ordinances, and regulations.

2. In carrying out the provisions of this CONTRACT, or in exercising any power or authority granted to the COMMISSION, there shall be no personal liability upon the authorized representatives of the COMMISSION, it being understood that in such matters they act as agents and representatives of the agency.
3. The COMMISSION shall be responsible for any and all damages to property or persons arising out of negligent act, error and/or omission in the COMMISSION's performance of the services under this CONTRACT.
4. The COMMISSION shall indemnify and hold harmless the CITY and all of their officers, agendas, and employees on account of any damages to persons or property resulting from negligence of the COMMISSION or for noncompliance with any applicable federal, state, or local laws.

VII. Nondiscrimination in Employment

1. In connection with the performance of services under this CONTRACT, the COMMISSION agrees not to discriminate against any employee or applicant for employment because of age, race, handicap, sex, physical condition, development disability as defined in sec. 51.01(5) Wis. Stats., sexual orientation as defined in sec. 111.32(13m) Wis. Stats., or national origin. This provision includes, but is not limited to, employment, upgrading, demotion, transfer, recruitment, recruitment advertising, layoff, termination, rates of pay, other forms of compensation, selection for training including apprenticeship.
2. Except with respect to sexual orientation, the COMMISSION agrees to take affirmative action to ensure equal employment opportunities. The COMMISSION agrees to post in conspicuous places, available for employees and applicants, notices setting forth the provisions of the nondiscrimination clause

VIII. Equal Employment Opportunity

1. The COMMISSION will, in all solicitations or advertisements for employees placed by or on behalf of the COMMISSION, state that all qualified applicants will receive consideration for employment without regard to race, color, religion, sex, or national origin.
2. The COMMISSION and CITY assure that no person shall on the grounds of race, color, national origin, or sex as provided by Title VI of the Civil Rights Act of 1964 and the Civil Rights Restoration Act of 1987 (P.L. 100.259) be excluded from participation in, be denied the benefits of, or be otherwise subjected to discrimination under any program or activity. The COMMISSION and CITY further assure every effort will be made to ensure non-discrimination in all of its programs and activities, whether those programs and activities are federally funded or not.

The Civil Rights Restoration Act of 1987 broadened the scope of Title VI coverage by expanding the definition of terms "programs or activities" to include all programs or activities of Federal Aid recipients, sub-recipients, and contracts, whether such programs and activities are federal assisted or not (Public Law 100259 [S.557] March 22, 1988.).

In the event that COMMISSION distributes federal aid funds to an additional subcontractor, the COMMISSION will include Title VI language in all written agreements and will monitor the additional subcontractor for compliance. The COMMISSION has an authorized Title VI Coordinator with the authority and responsibility for initiating and monitoring Title VI activities, preparing reports and other responsibilities as required by 23 Code of Federal Regulations (CFR) 200 and 49 Code of Federal Regulation 21.

3. The COMMISSION will comply with all provisions of Executive Order 11246, "Equal Opportunity" as amended by Executive Order 11375, and as supplemented in the Department of Labor regulations (41 CFR Part 60).
4. The COMMISSION will furnish all information and reports required by Executive Order 11246 and by rules, regulations, and orders of the Secretary of Labor, or pursuant thereto, and will permit access to its books, records, and accounts by the COMMISSION for purposes of investigation to ascertain compliance with such rules, regulations, and orders.
5. The COMMISSION will include the provisions of this section, "Equal Employment Opportunity" in every subcontract.

IX. Errors and Omissions

1. The COMMISSION shall be responsible for the accuracy of the services performed under this CONTRACT and shall promptly make necessary revisions or corrections to its services resulting from its negligent acts, its errors or its omissions without additional compensation. The COMMISSION shall give immediate attention to these revisions or corrections to prevent or minimize delay to the PROJECT. The COMMISSION shall be responsible to the CITY for any losses to or costs to repair or remedy as a result of the COMMISSION's negligent acts, errors, or omissions.
2. The COMMISSION warrants that the services to be provided under this CONTRACT will be executed in a workmanlike manner, consistent with professional standards of comparable work in this field.

X. Conflict of Interest

1. The COMMISSION warrants that neither it nor any of its affiliates has any financial or personal interest that would conflict in any manner with the performance of the Services under this CONTRACT, and that neither it nor any of its affiliates will acquire directly or indirectly any such interest.
2. The COMMISSION warrants that it will not employ for any services included under the provisions of this CONTRACT any person who is employed by the CITY at the time of execution or during the life of this contract without prior written approval from the CITY.
3. The COMMISSION warrants that it will immediately notify the CITY if an actual or potential conflict of interest arises or becomes known to the COMMISSION. Upon receipt of such notification, the CITY will review and written approval is required for the COMMISSION to continue to perform work under this CONTRACT.

XI. Certification Regarding Debarment

1. The COMMISSION certifies (by entering into this CONTRACT) that it and its principals (1) are not debarred, suspended, proposed for debarment, declared ineligible, or voluntarily excluded from covered transactions by any Federal department or agency; (2) have not been convicted of or had a civil judgment rendered against them within the previous three years; (3) are not indicted or otherwise criminally or civilly charged by a government entity; and (4) have not had one or more public transactions terminated for cause or default within the previous three years.
2. The COMMISSION agrees that it will not knowingly enter into any transaction with a person who is debarred, suspended, declared ineligible, or voluntarily excluded from participation in this transaction unless authorized by the CITY.

XII. Insurance Requirements

1. The COMMISSION shall procure and maintain for the life of the CONTRACT the following types and amounts of insurance from an insurance company(ies) authorized to do business in the State of Wisconsin.
 - Comprehensive General Liability - \$1,000,000 combined single limits per occurrence.
 - Auto Liability - \$300,000 combined single limits per occurrence.
 - Worker's Compensation – coverage satisfying statutory provisions of Chapter 102, Wis. Stats.; not less than \$100,000 employer's liability.

XIII. Certification Regarding Lobbying

1. The COMMISSION certifies (by entering into this CONTRACT) that no federal appropriated funds have been paid or will be paid by or on behalf of the COMMISSION to any person for influencing or attempting to influence an officer or employee of any agency, Member of Congress, officer or employee of Congress, or employee of a Member of Congress in connection with the awarding of any Federal contract, the making of any Federal loan, the entering into of any cooperative agreement, and the extension, continuation, renewal, amendment, or modification of any Federal contract, grant, loan or cooperative agreement.



MEMORANDUM

DATE December 29, 2025
TO Common Council
FROM Kaija Snyder, City Clerk
RE Transfer Alcohol License Application from El Jaripeo Menasha LLC, DBA El Jaripeo to El Palenque Mexican Gastropub LLC, DBA El Palenque (890 Lake Park Road, Menasha) - “Class B” (Intoxicating Liquor) and Class “B” (Fermented Malt Beverages); Ana Griselda Rivera, Agent

El Jaripeo Menasha, LLC ownership has chosen to cease business operations and transfer its alcohol license to a new business for use on the same premises. This transfer allows the new business, El Palenque Mexican Gastropub, LLC, to exercise the privileges of the original license for the remainder of the 2025-2026 licensing term. However, Wis. Stat. 125.04(12)(b)4.a. requires that the successor licensee meet all requirements for an original alcohol license. This memorandum describes the achievement of these requirements and the transfer agreement.

El Palenque submitted a new application for a “Class B” (intoxicating liquor) and Class “B” (fermented malt beverages) alcohol license for use at 890 Lake Park Road during the licensing term of January 6, 2026 – June 30, 2026. These application materials are attached.

According to Section 7-2-8 of the Menasha Municipal Code, El Palenque has been inspected and approved by the Health Department, Building Inspection Office, and Fire Department. Verification of these approvals is attached.

Other compliance requirements have also been met. Specifically, the property has no outstanding zoning or code violations and is in good standing with the Menasha Finance Department. El Palenque achieves residence requirements under Section 7-2-7(a) of the Menasha Municipal Code: the applicant submitted a written lease with a term exceeding one year. The Menasha Police Department facilitated and approved a criminal background check for agent Ana Griselda Rivera; Rivera additionally meets agent qualifications outlined in Wis. Stat. 125.04(5)(a)(5). Notification of application pendency was published in three consecutive issues of *The Post-Crescent* on December 15, 16, and 17, 2025.

El Jaripeo and El Palenque ownership each additionally signed a License Transfer Form furnished by the City of Menasha Clerk's Office. This form describes that El Jaripeo relinquishes its alcohol license effective January 6, 2026, and that El Palenque accepts transfer of the alcohol license on the same date, contingent upon Common Council approval. This form is attached.

Recommendation: Staff recommends approving transfer of El Jaripeo's "Class B" and Class "B" alcohol license to El Palenque for the January 6, 2026 – June 30, 2026 licensing term.

Form
AB-200

Alcohol Beverage License Application

For Municipal Use Only	
Municipality	Menasha
License Period	25-26

License(s) Requested: (up to two boxes may be checked)

- Class "A" Beer \$ _____ Class "B" Beer \$ TRANSFER
 "Class A" Liquor \$ _____ "Class B" Liquor \$ TRANSFER
 "Class A" Liquor (cider only) \$ _____ Reserve "Class B" Liquor \$ _____
 "Class C" Liquor (wine only) \$ _____

Fees	
License Fees	\$ 10
Background Check Fee	\$ N/A
Publication Fee	\$ 50 - PAID
Total Fees	\$ 60

Part A: Premises/Business Information			
1. Legal Business Name (individual name if sole proprietorship) <u>El Palenque Mexican Gastropub</u>			
2. Business Trade Name or DBA <u>El Palenque</u>			
3. FEIN <u>33-3509581</u>		4. Wisconsin Seller's Permit Number <u>456-1032148340-04</u>	
5. Entity Type (check one) <input type="checkbox"/> Sole Proprietor <input type="checkbox"/> Partnership <input checked="" type="checkbox"/> Limited Liability Company <input type="checkbox"/> Corporation <input type="checkbox"/> Nonprofit Organization			
6. State of Organization <u>Wisconsin</u>		7. Date of Organization <u>2-19-2025</u>	8. Wisconsin DFI Registration Number
9. Premises Address <u>890 Lake Park Rd</u>			
10. City <u>Menasha</u>		11. State <u>WI</u>	12. Zip Code <u>54952</u>
13. County <u>USA</u>		14. Governing Municipality: <input type="checkbox"/> City <input checked="" type="checkbox"/> Town <input type="checkbox"/> Village of: <u>Menasha</u>	15. Aldermanic District
16. Premises Phone		17. Premises Email <u>@gmail.com</u>	18. Website <u>Elpalenquemexicangastropub</u>
19. Premises Description - Describe the building or buildings where alcohol beverages are produced, sold, stored, or consumed, and related records are kept. Describe all rooms within the building, including living quarters. Authorized alcohol beverage activities and storage of records may occur only on the premises described in this application. Attach a map or diagram and additional sheets if necessary. <u>Building has Two storage rooms for alcohol storage under lock in the basement.</u>			
20. Mailing Address (if different from premises address) [REDACTED]			
21. City [REDACTED]		22. State [REDACTED]	23. Zip Code [REDACTED]

Part B: Questions			
1. Has the business (sole proprietorship, partnership, limited liability company, or corporation) been convicted of violating federal or state laws or local ordinances? Exclude traffic offenses unless related to alcohol beverages. <input type="checkbox"/> Yes <input checked="" type="checkbox"/> No If yes, list the details of violation below. Attach additional sheets if necessary.			
Law/Ordinance Violated		Location	Trial Date
Penalty Imposed		Was sentence completed? <input type="checkbox"/> Yes <input type="checkbox"/> No	
Law/Ordinance Violated		Location	Trial Date
Penalty Imposed		Was sentence completed? <input type="checkbox"/> Yes <input type="checkbox"/> No	

2. Are charges for any offenses pending against the business? Exclude traffic offenses unless related to alcohol . . . Yes No beverages.

If yes, describe the nature and status of pending charges using the space below. Attach additional sheets as needed.

3. Is the applicant business or any of its officers, directors, members, agent, employees, owners, or other related individuals or entities a restricted investor with any interest in an alcohol beverage producer or distributor? . . . Yes No
If yes, provide the name of the restricted investor and describe the nature of the interest.

4. Is the applicant business owned by another business entity? . . . Yes No
If yes, provide the name(s) and FEIN(s) of the business entity owners below. Attach additional sheets as needed.

4a. Name of Business Entity Kinesiology 360 Massage	4b. Business Entity FEIN 87-0955378
---	---

5. Have the partners, agent, or sole proprietor satisfied the responsible beverage server training requirement for this license period? Submit proof of completion. Yes No

6. Is the applicant business indebted to any wholesaler beyond 15 days for beer or 30 days for liquor/wine? Yes No

7. Does the applicant business owe past due municipal property taxes, assessments, or other fees? Yes No

Part C: Individual Information

List the name, title, and phone number for each person or entity holding the following positions in the applicant business or businesses listed in Part B, Question 4: sole proprietor, all officers, directors, and agent of a corporation or nonprofit organization, all partners of a partnership, and all members, managers, and agent of a limited liability company. Attach additional sheets if necessary.

Include Form AB-100 for each person listed below. Corporations and LLCs must appoint an agent by including Form AB-101.

Last Name	First Name	Title	Phone
Rivera	Ana Griselda	Owner	[REDACTED]

Part D: Attestation

One of the following must sign and attest to this application:

- sole proprietor
- one general partner of a partnership
- one corporate officer
- one member of an LLC

READ CAREFULLY BEFORE SIGNING: Under penalty of law, I have answered each of the above questions completely and truthfully. I agree that I am acting solely on behalf of the applicant business and not on behalf of any other individual or entity seeking the license. Further, I agree that the rights and responsibilities conferred by the license(s), if granted, will not be assigned to another individual or entity. I agree to operate this business according to the law, including but not limited to, purchasing alcohol beverages from state authorized wholesalers. I understand that lack of access to any portion of a licensed premises during inspection will be deemed a refusal to allow inspection. Such refusal is a misdemeanor and grounds for revocation of this license. I understand that any license issued contrary to Wis. Stat. Chapter 125 shall be void under penalty of state law. I further understand that I may be prosecuted for submitting false statements and affidavits in connection with this application, and that any person who knowingly provides materially false information on this application may be required to forfeit not more than \$1,000 if convicted.

Last Name Rivera	First Name Ana	M.I. Griselda
Title Owner	Email [REDACTED]	Phone [REDACTED]
Signature [Signature]		Date 10/22/25

Part E: For Clerk Use Only

Date Application Was Filed With Clerk 10/22/25	License Number	Date License Granted	Date License Issued
Signature of Clerk/Deputy Clerk		Date Provisional License Issued (if applicable)	

Alcohol Beverage Appointment of Agent

Date

Agent Type (check one)	
<input checked="" type="checkbox"/> Original (no fee)	<input checked="" type="checkbox"/> Successor (\$10 fee for municipal licensees only)

Part A: Business Information	
1. Legal Business Name (individual name if sole proprietor) El Palenque Mexican Gastropub	
2. Business Trade Name or DBA	
3. Entity Type (check one) <input checked="" type="checkbox"/> Limited Liability Company <input type="checkbox"/> Corporation <input type="checkbox"/> Nonprofit Organization	
4. Alcohol Beverage Business Authorization (check one) <input checked="" type="checkbox"/> Municipal Retail License <input type="checkbox"/> State Permit	5. If successor agent, provide State Permit or Municipal Retail License Number
6. Describe the reason for appointing a successor agent, if successor is checked above.	

Part B: Agent Information			
1. Last Name Rivera	2. First Name Ana	3. M.I. Griselda	
4. Email		5. Phone	
6. Home Address			
7. City	8. State	9. Zip Code	10. Date of Birth
11. Drivers License/State ID Number		12. Drivers License/State ID State of Issuance	

Part C: Agent Questions	
1. Have you satisfied the responsible beverage server training requirement? Submit proof of completion.	<input checked="" type="checkbox"/> Yes <input type="checkbox"/> No
2. Have you completed Form AB-100, Alcohol Beverage Individual Questionnaire (licensee) or Form AB-300, Alcohol Beverage Personal Questionnaire (permittee)?	<input checked="" type="checkbox"/> Yes <input type="checkbox"/> No
3. Have you been a Wisconsin resident for at least 90 continuous days? See instructions for exceptions.	<input checked="" type="checkbox"/> Yes <input type="checkbox"/> No

Continued →

Part D: Business Attestation

READ CAREFULLY BEFORE SIGNING: I, the **Undersigned**, authorize the above-named individual to act for the above-named corporation, nonprofit organization, or limited liability company with full authority and control of the premises and of all alcohol beverage activities on such premises. I certify that I am authorized by the above-named entity to authorize this individual to act on behalf of the entity. If I am appointing a successor agent, I rescind all previous agent appointments for this premises. Further, I understand that I may be prosecuted for submitting false statements and affidavits in connection with this application, and that any person who knowingly provides materially false information on this application may be required to forfeit not more than \$1,000 if convicted.

Last Name <i>Rivera</i>		First Name <i>Ana</i>	M.I. <i>Griselda</i>
Title <i>Owner</i>	Email [REDACTED]	Phone [REDACTED]	
Signature <i>[Signature]</i>		Date 10/22/25	

Part E: Agent Attestation

READ CAREFULLY BEFORE SIGNING: I, the **Agent**, hereby accept this appointment as agent for the above-named corporation, nonprofit organization, or limited liability company and assume full responsibility for the conduct of all alcohol beverage activities on the premises for the above-named business. I further understand that I may be prosecuted for submitting false statements and affidavits in connection with this application, and that any person who knowingly provides materially false information on this application may be required to forfeit not more than \$1,000 if convicted.

Last Name <i>Rivera</i>		First Name <i>Ana</i>	M.I. <i>G</i>
Signature <i>[Signature]</i>		Date 10/22/25	

Alcohol Beverage Individual Questionnaire

All individuals involved in the alcohol beverage business must complete this form, including:

- sole proprietor
- all partners of a partnership
- all officers, directors, and agent of a corporation or nonprofit organization
- members and agent of a limited liability company

Your alcohol beverage application or renewal is not complete until all required Individual Questionnaires are submitted.

Part A: Business Information				
1. Legal Business Name (individual name if sole proprietor) El Palenque Mexican Gastropub				
2. Business Trade Name or DBA				
3. Entity Type (check one)				
<input type="checkbox"/> Sole Proprietor	<input type="checkbox"/> Partnership	<input checked="" type="checkbox"/> Limited Liability Company	<input type="checkbox"/> Corporation	<input type="checkbox"/> Nonprofit Organization

Part B: Individual Information				
1. Last Name Rivera		2. First Name Ana		3. M.I. Griselda
4. Relationship to Business (Title) Owner		5. Email		6. Phone
7. Home Address				
8. City				
9. State		10. Zip Code		11. Date of Birth
12. Drivers License/State ID Number			13. Drivers License/State ID State of Issuance	

Part C: Address History				
1. Do you currently live in Wisconsin?				<input checked="" type="checkbox"/> Yes <input type="checkbox"/> No
If yes, provide the month and year when you permanently moved to Wisconsin				(MM/YYYY) 01/03/2007
2. List in chronological order all of your addresses within the last 5 years. Attach additional sheets if necessary.				
Previous Address 1		City	State	Zip Code
Previous Address 2		City	State	Zip Code
Previous Address 3		City	State	Zip Code
Previous Address 4		City	State	Zip Code
Previous Address 5		City	State	Zip Code
3. List all states and counties you have lived in as an adult. Attach additional sheets if necessary.				
State	County	State	County	State
CA	Orange	WI	Outagamie	WI
State	County	State	County	State
			Winnaconie	

Continued →

Part D: Criminal History

1. Have you ever been convicted of any offenses (excluding traffic offenses unless related to alcohol beverages) for violation of any federal, Wisconsin, or another state's laws or of any county or municipal ordinances? Yes No

If yes to question 1, please list details of each conviction below. Attach additional sheets as needed.

Law/Ordinance Violated	Location	Conviction Date
Penalty Imposed		Was sentence completed? <input type="checkbox"/> Yes <input type="checkbox"/> No
Law/Ordinance Violated	Location	Conviction Date
Penalty Imposed		Was sentence completed? <input type="checkbox"/> Yes <input type="checkbox"/> No
Law/Ordinance Violated	Location	Conviction Date
Penalty Imposed		Was sentence completed? <input type="checkbox"/> Yes <input type="checkbox"/> No

2. Are charges for any offenses currently pending against you (excluding traffic offenses unless related to alcohol beverages) for violation of any federal, Wisconsin, or another state's laws or any county or municipal ordinances? Yes No

If yes to question 2, describe nature and status of pending charges using the space below. Attach additional sheets as needed.

Part E: Attestation

READ CAREFULLY BEFORE SIGNING: Under penalty of law, I have answered each of the above questions completely and truthfully. I certify that I am not prohibited from participating in this business due to any involvement in another tier of the alcohol beverage industry as a restricted investor. I understand that any license issued contrary to Wis. Stat. Chapter 125 shall be void under penalty of state law. I further understand that I may be prosecuted for submitting false statements and affidavits in connection with this application, and that any person who knowingly provides materially false information on this application may be required to forfeit not more than \$1,000 if convicted.

Signature

Date
10/22/25



Original Alcohol License Inspections & Compliance Report
 City of Menasha – Office of the City Clerk, 100 Main Street Suite 200, Menasha, WI 54952

BUSINESS ENTITY (d/b/a): El Palenque Mexican Gastropub
INSPECTED PREMISES (PROPERTY ADDRESS): 890 Lake Park Road, Menasha
OWNER: Ana Griselda Rivera

HEALTH INSPECTION

I, **TODD DREW**, of the **CITY OF MENASHA'S HEALTH DEPARTMENT**, inspected the above premises and can confirm, upon my inspection, the premises does indeed conform to the sanitary, safety and health requirements, and the regulations of the State Board of Health and the local Board of Health as applicable to restaurants, as required in Sec. 7-2-9 of the City of Menasha's Municipal Code.

The above premises can be conditionally approved for its liquor license upon the understanding the following deficiencies noted below will be remedied within sixty (60) days of license issuance and verified via a follow-up inspection; an accompanying inspection report may be provided.

~~HOLD PERMITS BECAUSE RELEASE OF FOOD LICENSE.~~

~~NOTHING PERIOD HOLD OF FOOD SYSTEM.~~

RESTAURANT LICENSE RELEASED 12/4/25 ^{TD}

X  Date: ~~11/10/25~~ 12/4/25 ^{TD}

COMMERCIAL BUILDING INSPECTION

I, **JANE DRAGER**, of the **CITY OF MENASHA'S BUILDING INSPECTION OFFICES**, inspected the above premises and can confirm, upon my inspection, the premises does indeed conform to the sanitary, safety and health requirements of the State Building Code, and the regulations of the State Board of Health and the local Board of Health as applicable to restaurants, as required in Sec. 7-2-9 of the City of Menasha's Municipal Code.

The above premises can be conditionally approved for its liquor license upon the understanding the following deficiencies noted below will be remedied within sixty (60) days of license issuance and verified via a follow-up inspection. A formal inspection report shall accompany the findings below.

X  Date: 12/11/2025 ✓

FIRE DEPARTMENT INSPECTION

I, **JERRY MAVROFF** of **NEENAH-MENASHA FIRE RESCUE**, can confirm a representative of the department reviewed the above premises and can confirm the inspection conforms with the occupancy compliance as determined by the International Fire Code as adopted by the City of Menasha, except where identified with the attached fire inspection report.

The above premises can be conditionally approved for its liquor license upon the understanding the following deficiencies noted below will be remedied within thirty (30) days of license issuance and verified via a follow-up inspection. In lieu of a formal inspection, a prior inspection report dated within the past six (6) months from the NM Fire Rescue may be used (and if so, indicate below and report shall be attached).

X *Jerry Mavroff* 460 Date: 11/21/25

CLERK'S OFFICE – INTERDEPARTMENTAL & STATUTORY COMPLIANCE REQUIREMENTS

I, **KAIJA SNYDER**, of the **CITY OF MENASHA CLERK'S OFFICE**, received confirmation from the below departments or organizations that the above named applicant complies with Wisconsin State Statute and Menasha Municipal Code requirements for license issuance.

RESIDENCE REQUIREMENTS

Confirmed the above named applicant meets residence requirements described in Sec. 7-2-7(a) of the Menasha Municipal Code on 10/22/25.

COMMUNITY DEVELOPMENT / ZONING REVIEW

Confirmed no ordinance violations for above premises on 10/24/25.
Confirmed no zoning violations for above premises on 11/4/25.

MENASHA POLICE DEPARTMENT

Confirmed of criminal background check approval of all organization agents, officers, and directors listed on original application on 9/4/25.

MENASHA FINANCE DEPARTMENT

Confirmed that there are no outstanding tax payments or financial obligations on personal or commercial properties on 10/24/25.

PUBLICATION OF NOTICES IN OFFICIAL NEWSPAPER

Confirmed publication of three consecutive notices in the City's official newspaper, *The Post-Crescent*, on 12/15/25, 12/16/25, and 12/17/25.

X *Kaija Snyder* Date: 12/18/25



License Transfer Form

Reference: Sec. 7-2-11, City of Menasha Municipal Code

To be filed with the Clerk's Office upon mutual agreement between current license holder and applicant seeking licensure at the same premises. Submission of this completed form relinquishes the issued license to the City of Menasha for reissuance to the indicated applicant, provided they meet requirements outlined in Title 7 of the Menasha Municipal Code and Chapter 125 of the Wisconsin Statutes.

Business Relinquishing License to City of Menasha

Corporation or LLC Name: El Jaripeo Menasha, LLC
DBA Name: El Jaripeo
Premises Address: 890 Lake Park Road, Menasha, WI 54952
Alcohol License Class(es): "Class B", Class "B"
License Number: 25-CBB-5

All officers, directors, agent, or sole proprietor of the above-listed corporation or nonprofit organization, or all partners, members, managers, and agent of the above listed limited liability company hereby sign agreeing to relinquish the above listed alcohol license to the City of Menasha, effective the 6th day of January, 2026.

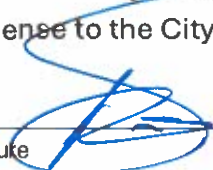
Signature 	Antonio Sandoval
Signature _____	Printed Name _____
Signature _____	Printed Name _____
Signature _____	Printed Name _____



Office of the City Clerk
100 Main Street, Suite 200
www.menashawi.gov
(920) 967-3608

Business Applying for Licensure from City of Menasha

Corporation or LLC Name: El Palenque Mexican Gastropub, LLC
DBA Name: El Palenque
Premises Address: 890 Lake Park Road, Menasha, WI 54952

Alcohol License Class(es): "Class B", Class "B"
License Number: 25-CBB-5

All officers, directors, agent, or sole proprietor of the above-listed corporation or nonprofit organization, or all partners, members, managers, and agent of the above listed limited liability company hereby sign accepting transfer of the above listed alcohol license from the City of Menasha, contingent upon achievement of alcohol licensing requirements outlined in Title 7 of the Menasha Municipal Code and Chapter 125 of the Wisconsin Statutes, effective the 6th day of January, 2026.

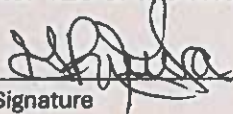
Signature

Ana Griselda Rivera
Printed Name

Signature

Printed Name

Signature

Printed Name

Signature

Printed Name

OFFICE USE ONLY

The above-listed license was surrendered to the City of Menasha Clerk's Office 12/26/25.

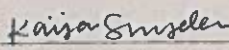
Clerk Signature: 



MEMORANDUM

Date: December 30, 2025
To: Common Council
From: Megan Sackett, Director Parks and Recreation Dept/ms
RE: Professional Services Agreement(s) between the City of Menasha and MSA Professional Services, Inc., for Design and Construction Management Services – Jefferson Park Aquatic Facility

In November 2025, the City of Menasha Common Council approved the selection of MSA Professional Services, Inc. to provide conceptual design services for the Menasha Aquatic Facility at Jefferson Park.

MSA was selected based on their demonstrated ability to lead the project from conceptual design through technical development and to effectively position the project for public engagement, funding opportunities, bidding, and eventual construction.

Since that time, City staff have been working with MSA to plan the design process for the new facility, which will include input and feedback from City staff, elected officials, and the public.

Recommendation

Move to approve a Professional Services Agreement(s) between the City of Menasha and MSA Professional Services, Inc., for Design and Construction Management Services-Jefferson Park Aquatic Facility, contingent upon approval as to form by City Attorney Struve.



Jefferson Park Aquatic Facility Design
City of Menasha | October 27, 2025

*Your Place on the Water,
Reimagined for the Next Generation.*





WHY THE MSA TEAM STANDS OUT!

October 27, 2025

Megan Sackett, Director of Parks and Recreation
100 Main Street, Suite 200
Menasha, WI 54952

Re: Jefferson Park Aquatic Facility Design Proposal

Dear Megan,

MSA Professional Services, Inc. (MSA), in partnership with Water Technology, Inc. (WTI), is enthusiastic about the opportunity to collaborate with the City of Menasha on the design of a transformative aquatic facility, one that reflects your waterfront identity, builds on the Jefferson Park Vision Plan, and serves as a lasting community asset. Congratulations on turning the page from your previous aquatic facility and embracing a bold vision for the next chapter. Our team is well-positioned to support the City in opening the new facility by Spring 2027.

WTI, a leading international acclaimed aquatic design firm with deep Wisconsin roots, joins MSA in offering a seamless, full-service team with unmatched expertise in aquatic planning, design, and operations. Together, we've successfully delivered many aquatic facilities including locations in Appleton, Evansville, and Wisconsin Rapids that balance innovation, operational efficiency, and community identity.

We understand this project is more than a pool; it's a community focal point for gathering, learning, and recreation. In this proposal we have developed a custom tailored approach to expedite and bring forward a creative community-centered process, help build buy-in, and assist in identifying funding opportunities to make this vision a reality.

Our team has done this before and will do it again by supporting the City with strong project leadership from concept through construction, resulting in a new Aquatic Center that fosters wonderful user experiences, community pride and the region to partake in your very special place on the water.

Please feel free to contact me at (608) 355-8884 or carndt@msa-ps.com with any questions.

We welcome the opportunity to connect and explore how our team can help Menasha realize its vision for Jefferson Park. We're ready to listen, collaborate, and deliver a facility that reflects your values and serves future generations.

Sincerely,
MSA Professional Services, Inc.

E. Carter Arndt, AIA, NCARB
Project Architect & Project Manager

Dan Rammer, PE
Client Liaison & Civil Project Engineer

Local Roots, National Reach, and Proven Partnership:

MSA and WTI combine deep Wisconsin roots with national aquatic leadership. Our partnership has delivered successful aquatic centers in Appleton, Evansville, and Wisconsin Rapids, facilities that reflect thoughtful design, operational efficiency, and strong community support.

Cold-Climate Aquatic Design:

We design for Wisconsin's climate, prioritizing energy efficiency, winter adaptability, and long-term operational value.

Engagement and Visual Communication:

MSA's engagement toolbox, StoryMaps, surveys, pop-up booths, and referendum support builds public trust and momentum. WTI's immersive renderings and transparent design philosophy support safety and staffing efficiency.

Funding Strategy and Support:

MSA has helped clients secure over \$625M in grants and low-interest loans. Our funding specialists are ready to help Menasha identify and pursue financial support.

Full-Service Team:

MSA offers architecture, engineering, landscape, MEP, and funding services under one roof. WTI adds specialized aquatic design and operational insight, streamlining delivery and coordination.

Construction Administration:

Our team brings decades of experience managing municipal aquatic projects, advocating for quality, compliance, and timely delivery.

Commitment to Menasha:

With our Appleton office just 11 miles from Jefferson Park, we offer local access and regional familiarity. Our approach reflects Menasha's priorities, accessibility, water safety, sustainability, and community engagement, and is designed to deliver a facility that embodies the Jefferson Park Vision Plan and serves the community for generations.

>> [MSA acknowledges receipt of Addenda A and B.](#)



TABLE OF CONTENTS

FIRM INFORMATION

1

Showcasing our services, structure, and key contacts.

EXECUTIVE SUMMARY

2

Highlighting our commitment, qualifications, and readiness to lead your project.

PROJECT TEAM

3

Introducing the experts driving your project forward.

PROJECT EXPERIENCE

7

Demonstrating success through relevant, proven work.

PROJECT APPROACH AND UNDERSTANDING

11

Outlining how we'll manage and deliver your vision.

PROJECT PLAN AND TIMELINE

14

Mapping out milestones to keep your project on track.

*A Splash of Innovation,
A Wave of Community Connection.*



MSA PROFESSIONAL SERVICES – LEAD

MSA Professional Services, Inc. (MSA) specializes in the creative and sustainable development of communities. We achieve this by building honest, open relationships that go beyond the project to become a trusted source of expertise and support for immediate challenges and long-term goals. Big or small, we do whatever it takes to meet each need, working to make communities stronger in the process. **It's more than a project. It's a commitment.** MSA's roots reach back to 1919. Our firm is over 500 employees strong, including engineers, architects, landscape architects, planners, funding experts, surveyors, GIS specialists, environmental scientists, and other specialists who serve clients nationally. MSA excels at aquatics, parks and recreation, and helping clients identify grant and funding sources and then delivering high-quality, cost-effective solutions.

SERVICES PROVIDED/UTILIZED FOR THIS PROJECT:

- Team Leadership
- Architecture Design
- HVAC, Electrical, Plumbing, and Fire Protection Engineering
- Funding
- Site Civil and Structural Engineering
- Landscape Architecture
- Public Engagement
- Park and Recreation Planning



Visit www.msa-ps.com for a comprehensive overview of the services MSA offers. Given our extensive range of services tailored to municipalities, we have provided the abbreviated list above to highlight those most relevant to this project.



Local Office Only 11 Miles Away!

2901 E. Enterprise Avenue
Suite 500
Appleton, WI 54913
~ 39 employees

500+
TEAM
MEMBERS

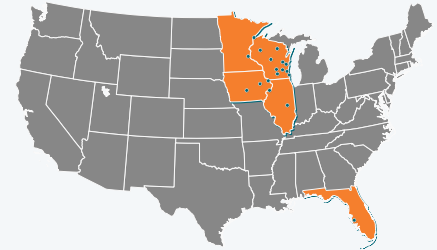

MSA 18 OFFICE LOCATIONS



Type of Corporation

100% ESOP
S Corporation

44
Industry Awards
Earned Since 2017

Established
1962

Additional Midwest Locations & Employee Counts

Baraboo, WI (104), Beaver Dam, WI (21), Cedar Rapids, IA (10), Champaign, IL (17), Des Moines, IA (27), Dubuque, IA (22), Duluth, MN (22), Kiel, WI (23), Madison, WI (108), Marshfield, WI (25), Mequon, WI (14), Milwaukee, WI (32), Quad Cities, IA/IL (10), Rhinelander, WI (20), Rice Lake, WI (17), St. Paul, MN (40)



\$625+ MILLION

GRANTS & LOW-INTEREST LOANS
We've helped our clients secure to help offset the cost of infrastructure projects

*Office locations have been identified on each key personnel resume on pages 4-6.

Main Project Contact: E. Carter Arndt, Project Architect & Project Manager | (608) 355-8884 | carndt@msa-ps.com

WATER TECHNOLOGY INC. – AQUATICS SPECIALIST

The WTI team is a highly qualified group of individuals comprised of creative architects, landscape architects, engineers, designers, business developers and administrators, all with a passion for aquatics. Together, we combine our talents to develop original, aquatic facilities from concept to reality. In addition, WTI maintains solid relationships with other consultants and contractors and continues to set the standards in the aquatic industry across the United States and around the world.

- Established in 1983
- Largest Aquatic Design Firm in North America, Staff of 70+
- Quality Control Implementation
- Collaborative Team Process
- International Portfolio

SERVICES PROVIDED/UTILIZED FOR THIS PROJECT:

- Aquatic Planning, Aquatic Design, Aquatic Engineering, and Construction Administration



Visit wtiworld.com for a full overview of WTI's services.

Type of Corporation
S Corporation

Established 1983

Office Location
100 Park Avenue
Beaver Dam, WI 53916

2 US OFFICE LOCATIONS



STATEMENT OF INTEREST AND QUALIFICATIONS

MSA, in partnership with WTI, is pleased to submit our proposal to lead the design and delivery of the Jefferson Park Aquatic Facility. We are ready to support the City of Menasha from visioning through construction, delivering a facility that reflects community values, supports water safety, and enhances Jefferson Park for generations to come.

We understand the significance of this project to Menasha's identity as Your Place on the Water. Our team is well-positioned to build on the Jefferson Park Vision Plan and WTI's prior evaluation of the aquatic facility, providing continuity and maintaining project momentum. Jefferson Park is a regional destination and cherished gathering space, and the envisioned aquatic facility will serve as a cornerstone for inclusive recreation, education, and multigenerational connection.

MSA and WTI bring deep expertise in aquatic facility design, with a strong record of successful projects in Appleton, Evansville, and Wisconsin Rapids, each completed with public support and operational success.



Our work at Witter Park Aquatic Center earned a WRMCA Complex Project Award, demonstrating our ability to deliver transformative, multiseason facilities that exceed expectations.

Our Appleton office, located just 11 miles from Jefferson Park, offers direct access to local staff who understand the region's aquatic needs, community values, and municipal processes. With deep ties to the Fox Valley, we are committed to being engaged, responsive, and present throughout every phase of the project.

*We see this as a once-in-a-generation opportunity to create a transformative aquatic facility—one that honors Menasha's waterfront legacy, meets evolving community needs, and strengthens Jefferson Park as a regional destination. **We're excited to partner with the City to bring this inclusive, community-loved vision to life.***

We offer a full-service team with expertise in architecture, engineering, landscape design, aquatics, sound systems, pool furniture procurement, and funding. Our phased approach, master planning, public engagement, design, and construction, is tailored to Menasha's goals, timeline, and budget. We deliver everything from renderings and budget projections to technical specifications and construction documents, with a focus on operational efficiency and long-term value.

»» *Our Wisconsin-based aquatic centers are built for durability and seasonal flexibility, featuring amenities such as warming houses, climbing walls, slide complexes, and lazy rivers. We design for meaningful participation, incorporating inclusive features like zero-depth entries, ADA-accessible bathhouses, and sensory-friendly play zones..*

We understand Menasha's priorities: accessibility, water safety, sustainability, and community engagement. Our outreach tools, StoryMaps, surveys, pop-up booths, and referendum support, build public trust and momentum. We will collaborate with City staff to facilitate outreach meetings, gather input from diverse stakeholders, and develop materials that foster consensus and support. Our funding specialists have helped clients secure over \$625M in grants and low-interest loans, and we're ready to assist Menasha in identifying and pursuing financial support.

As lead consultant, MSA will serve as the City's advocate, managing quality, compliance, and timely delivery. Should the City extend construction oversight services, our team is prepared to continue as a trusted partner, providing continuity and responsive administration throughout the build. Our collaborative approach emphasizes transparency, responsiveness, and long-term partnership with City staff, elected officials, and the public.

*Together, Bringing the Strength of **500+** Aquatic Projects Completed in Wisconsin.*



ONE TEAM. ONE VISION. ONE SOLUTION.



*Designing with Purpose:
Inclusive, Local, and
Built to Endure.*

Services will be provided in collaboration between MSA and WTI. MSA will serve as the team leader and primary client contact, overseeing site assessment, coordination of utilities, park/dry-play amenities, and architectural, mechanical, and structural systems. WTI will focus on all aspects of aquatics, from operations and maintenance to the physical design of the pools and equipment, bringing specialized expertise in aquatic center planning, schematic design, engineering, and cost estimating. Our broad knowledge of both park and aquatic facilities supports accurate forecasting and informed decision-making throughout the project.



A FULLY INTEGRATED TEAM FOR JEFFERSON PARK

MSA + WTI offer a one-stop-shop team with expertise in aquatic design, architecture, engineering, and public engagement. Our coordinated approach includes in-house specialists in structural, electrical, plumbing, HVAC, aquatic sound, and furnishings, streamlining communication and maintaining consistency across all phases. From concept and outreach to technical design and construction oversight, we can deliver a modern, accessible aquatic facility that reflects the City's vision.



FUNDING EXPERTISE

MSA's funding team helps bring projects to life by identifying, bundling, and managing funding sources. With deep experience across grant, loan, and principal forgiveness programs, we navigate complex requirements, coordinate timelines, and handle program details, maximizing financial support for community-driven projects.



COMMUNITY ENGAGEMENT

We believe aquatic facilities should reflect the people they serve. Our team leads inclusive outreach to engage residents, nonprofits, businesses, and local leaders, building a shared vision through tools that reach all ages, abilities, and backgrounds. This approach builds trust, strengthens support, and results in a facility the whole community can take pride in.

PARKS AND RECREATION EXPERTISE

We work closely with communities to build greater awareness of residents' wants and needs.

How residents perceive the quality of life within their community can be attributed to the quality of parks and recreational facilities available to them. MSA has helped numerous clients through the planning, development, and revitalization of recreational amenities, including aquatic facilities, parks, waterfront developments, multiuse paths, and athletic facilities.

MSA designs and reimagines aquatic and recreational facilities that promote engagement, community pride, and quality of life. We help secure funding to make these visions a reality. From splash pads to Olympic-sized pools, our designs serve all ages and abilities. Features can stand alone or be integrated into larger park settings with amenities like bathhouses, concessions, sports courts, and trails. Whatever your vision, we help bring it to life with the right splash factor.



**Project Architect
& Project Manager**35 Years
Experience

33 Years With MSA

 Baraboo, WI**E. Carter Arndt, AIA, NCARB**

B.A., Architecture, Iowa State University

Project Architect, WI, IA, IL | National Council of Architectural Registration Boards

Carter is a municipal architect with a specialty in parks and recreation and serves as MSA's Aquatic Team Leader. He is dedicated to planning and designing dynamic facilities that respond to their environment, context, and the communities they serve. His design experience includes new construction, additions, and remodeling of parks, recreation facilities, community centers, and aquatic complexes. Carter brings deep expertise in designing inclusive, community-centered aquatic and civic facilities.

Similar Project Experience

- Erb Park and Pool, Appleton, WI
- Witter Park Aquatic Center, Wisconsin Rapids, WI
- Evansville Aquatic Center, Splash Pad and Parks, Evansville, WI
- Sunset Pool, Elkhorn, WI

Key Skills

- \$90 M+ in aquatic projects
- Designs aquatic and civic spaces that reflect community priorities
- Conducts feasibility studies and cost evaluations to guide planning
- Applies universal design and ADA principles for inclusive access
- Specializes in parks, recreation, and municipal architecture

**Architectural
Designer**7 Years
Experience

7 Years With MSA

 Baraboo, WI**Justine Good**

B.S., Architecture, University of Wisconsin-Milwaukee

American Institute of Architects - Wisconsin

Justine's experience includes project CAD drafting and detailing in Revit and AutoCAD to develop construction drawings and working directly with the project architect. Some of her other experiences include reviewing shop drawings and digital model development.

Similar Project Experience

- Evansville Aquatic Center, Splash Pad and Parks, Evansville, WI
- Randolph Community Pool, Randolph, WI
- Memorial Park, Barneveld, WI
- Fireman's Park, Verona, WI

Key Skills

- Develops construction documents that support civic and community infrastructure
- Contributes to public works and park facility design through detailed drafting
- Applies digital modeling tools to enhance design clarity and coordination
- Supports construction administration through shop drawing review

**Aquatics Project
Director**41 Years
Experience

28 Years With WTI

 Beaver Dam, WI**Matt Freeby, AIA, LEED® AP, NCARB**

Masters Architecture, Washington University | B.A., Finance, University of

Wisconsin-Whitewater | B.A., Architecture, Washington, University

AIA Architect: AL, AR, CA, DE, FL, HI, IN, LA, MI, MN, MO, NE, NJ, NM, NV, NY,

OK, RI, TN, UT, WA, WI | LEED® Accredited Professional, NSPF Certified Pool/

Spa Operator (CPO) | Themed Entertainment Association, American Institute of

Architects, National Council of Architectural Registration Boards

Matthew Freeby brings extensive experience in designing and constructing various building types and structures. He has managed projects ranging from \$1 million to \$100 million, from conceptual planning to construction management. He has advanced knowledge in green building practices and sustainable aquatic design. He defines scope, goals, and deliverables in collaboration with senior management. His attention to detail and pursuit of excellence provides the industry benchmark in aquatic design.

Similar Project Experience

- Erb Park and Pool, Appleton, WI
- Leonard-Leota Park and West Side Park, Evansville, WI
- Witter Park Aquatic Center, Wisconsin Rapids, WI
- Evansville Aquatic Center, Splash Pad and Parks, Evansville, WI

Key Skills

- Leads large-scale aquatic projects from concept to construction
- Registered Architect in 22 states with LEED® AP and CPO credentials
- Expert in sustainable aquatic design and green building practices
- Delivers high-quality outcomes through detail-oriented project management



Aquatics Designer

4 Years Experience

4 Years With WTI

 Beaver Dam, WI

Taylor Turnquist, Assoc. AIA

B.S., Architectural Studies, University of Wisconsin-Milwaukee
NSPF Certified Pool/Spa Operator (CPO)

Taylor blends creativity and technical skill. Her background in floral and interior design sparked a passion for spatial composition and the emotional impact of well-crafted environments. Taylor is involved in all phases of design, from early sketches to final files, bringing care and creativity to each project. Her intuitive approach, attention to detail, and enthusiasm make her a valuable asset to any project team.

Similar Project Experience

- Evansville Aquatic Center, Splash Pad and Parks, Evansville, WI
- Soderholm Aquatic Center at UW-Madison, Madison, WI
- Milwaukee County Aquatic Facility Study, Milwaukee, WI
- Randolph Aquatic Center Randolph, WI

Key Skills

- Skilled in AutoCAD, Revit, Lumion, and Adobe Creative Suite
- Refines concepts into detailed design plans
- Balances creative vision with technical precision
- Experienced in aquatic concept development and rendering
- Supports public engagement through design presentations



Aquatics Project Manager

8 Years Experience

2 Years With WTI

 Beaver Dam, WI

Adam Janesz

B.S., Construction Management, Construction Management Technology, Eastern Michigan University
NSPF Certified Pool/Spa Operator (CPO), STSC Certification, OSHA 30-Hour

Adam excels in leading diverse teams and managing mid to large-scale projects. He enriches projects by providing unique insights into design decisions, risk mitigation, cost control, schedule management, and quality assurance. Known for his past in-depth aquatic construction experience, strong communication skills and ability to build strong relationships, Adam brings incredible value to each project team. He is an avid learner committed to remaining at the forefront of emerging trends and best practices in the aquatic industry.

Similar Project Experience

- Kohler Spa Phase II, Kohler, WI
- Erickson Pool Mechanical Renovation, La Crosse, WI
- Ridgewood on the River Pool Renovation in Plover, WI
- La Crosse Area YMCA, La Crosse, WI

Key Skills

- Experienced in managing mid to large-scale aquatic facility projects
- Skilled in cost control, schedule management, and quality assurance
- Revit Certified Professional and CPO credentialed
- Knowledgeable in construction safety and risk mitigation practices



Landscape Architect

20+ Years Experience

1 Years With MSA

 Milwaukee, WI

Kevin Byrne, PLA, ASLA, LEED® AP BD+C

B.S., Landscape Architecture, University of Wisconsin-Madison
Professional Landscape Architect, WI, IL | LEED® Accredited Professional BD+C, American Society of Landscape Architects

Kevin brings deep expertise in site development, civic campus design, and outdoor gathering spaces. He is actively involved in all aspects of design and project management, collaborating with stakeholders and design teams to integrate architecture and site into cohesive, user-focused environments. His broad project background and construction insight foster creative solutions grounded in constructability, maintenance, and sustainability, resulting in engaging designs that stand the test of time.

Similar Project Experience

- Wade Bowl Park Master Plan and Splash Pad Construction, Superior, WI
- Randolph Park and Pool Master Plan, Randolph, WI
- Legends Park Splash Pad Master Plan, Reedsburg, WI
- Clausen Park Improvements, Fox Lake, WI

Key Skills

- Leads site planning and plans and designs integrated aquatic site layouts
- Implements sustainable, LEED®-aligned solutions
- Designs athletic and recreational amenities for public use
- Manages delivery from concept to construction Applies inspection and construction expertise for lasting impact



Park and Recreation Civil Expert

17 Years Experience

5 Years With MSA

 Baraboo, WI

Marcus Rue, PE

B.S. Civil Engineering, University of Wisconsin-Platteville
Professional Engineer, WI, LA, TN

Marcus is a civil engineer with expertise in parks, waterfronts, and trail infrastructure. He focuses on constructible, sustainable designs and efficient project delivery. With experience in stormwater systems, boat launches, and public space enhancements, Marcus supports seamless execution from concept through construction, with designs that reflect community needs and respond to site conditions.

Similar Project Experience

- Wade Bowl Park Master Plan and Splash Pad Construction, Superior, WI
- Webb Park Splash Pad, Reedsburg, WI
- Evansville Aquatic Center, Splash Pad and Parks, Evansville, WI
- Memorial Park, Barneveld, WI

Key Skills

- Designs parks, trails, and waterfront infrastructure
- Applies stormwater and grading expertise to site planning
- Reviews designs for constructability and phasing
- Coordinates with stakeholders for seamless delivery
- Solves technical challenges in real time

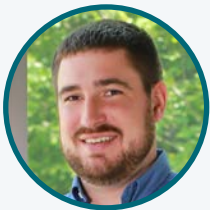

Client Liaison, Civil Project Engineer

12 Years Experience

12 Years With MSA

 Appleton, WI

Dan Rammer, PE

B.S., Civil Engineering, University of Wisconsin-Platteville
Professional Engineer, WI

Dan is a municipal engineer with expertise in utility design, park site development, and construction coordination. He collaborates closely with municipalities and contractors to deliver cost-effective solutions that meet community needs. Dan's experience spans park and recreation, stormwater and sanitary systems, water main design, and civil site planning, critical components for aquatic facility development.

Similar Project Experience

- Evansville Aquatic Center, Splash Pad and Parks, Evansville, WI
- Splashpad and Park Improvements, Nekoosa, WI
- Kuckuk and Memorial Park Improvements
- Village Park Master Planning, North Fond du Lac, WI

Key Skills

- Designs utility systems for aquatic infrastructure
- Navigates WDNR permitting for smooth approvals
- Oversees construction for quality and compliance
- Plans civil sites that support park functionality
- Coordinates with municipalities to meet project goals



Funding Specialist

14 Years Experience

10 Years With MSA

 Baraboo, WI

Brittney Mitchell

B.A., Marketing and Business Administration, University of Wisconsin-Whitewater

Brittney leads MSA's in-house funding team and provides comprehensive oversight of project financing from concept through completion. She specializes in identifying and securing funding opportunities, including grants, principal forgiveness, and loan programs, to tailor financial packages that meet community needs. Brittney is experienced in Davis-Bacon Labor Standards compliance and payroll review reporting, supporting regulatory adherence throughout the project lifecycle.

Key Skills

- Grant and loan program expertise
- Project financing and administration
- Regulatory compliance and reporting
- Funding strategy development
- Grant application and documentation management

Additional In-house Support Services To Be Provided

- Structural
- Electrical
- Architectural Support Staff
- Plumbing
- HVAC
- Engineering Support Staff
- Aquatic Sound and Furnishings

WITTER PARK AQUATIC CENTER

WISCONSIN RAPIDS, WI



The Witter Park Aquatic Center demonstrates our ability to deliver large-scale, multiseason recreational destinations that align with long-term community plans. This project showcases our expertise in designing inclusive, high-impact aquatic environments that support year-round use, operational efficiency, and regional appeal.

- Site Size: 24 acres
- Pool Surface Area: 12,900 square feet
- Buildings: 15,000 square feet



Complex Project Award for a Municipal Facility from the Wisconsin Ready Mixed Concrete Association (WRMCA)

Project Timeline/Schedule

- Design: December 2016 - December 2017
- Construction: June 2019 - June 2020

Architect/Engineer Estimate: \$10,934,000

Awarded Bid and Final Cost

Awarded: \$10,817,485 | Final: \$10,936,106

*** Increase due to minor existing conditions/Owner-directed changes and volatile bidding market in 2022.*

Client Reference

Joe Eichsteadt, City Engineer
(715) 421-8251 | jeichsteadt@wirapids.org

Project Outcome

The Witter Park Aquatic Center fulfilled the final phase of Wisconsin Rapids' long-range recreation plan, transforming Witter Field into a vibrant, multiseason destination. The facility has become a cornerstone of community life, offering inclusive amenities for all ages and supporting year-round programming, from summer aquatics to winter ice skating. With consistently high attendance and strong public support, the project has elevated the quality of life, fostered civic pride, and positioned Wisconsin Rapids as a regional hub for active living.

Project Team to Work on Your Project

E. Carter Arndt, Matt Freeby

Home to 20 city parks, six golf courses, seven area lakes, and an abundance of biking, hiking, birding, and watersport opportunities, Wisconsin Rapids is finding itself emerging as a recreation hot spot, not to mention, a premier destination for all-season aquatic activity. The community's 2012 Comprehensive Outdoor Recreation Plan (CORP) identified a three-phase approach to expanding its recreational programming. Phase three, and perhaps the city's crowning achievement to date, was the development of a regional aquatic center and recreational park complex at Witter Field.

MSA was chosen to lead the design of the facility, a complex and ambitious project that was completed just over one year later, in June 2020. The facility offers something for everyone: three pools including a tot pool with two water slides, spray features and a tot lazy river; a leisure pool with a play area, basketball hoops, water walk, lazy river with a "rapids" action channel, tube water slide, plunge pool and body water slide; and a recreation pool that features basketball hoops, lap swimming, a zip line feature, diving board and climbing wall.

The main aquatic center building and bath house is a clean, modern design, home to an admissions lobby, concessions, a community gathering room, and changing rooms. Outside, visitors can stroll the well-lit, landscaped property on pedestrian paths, lounge along the pool deck under colorful shade structures, sun themselves on a grass sunbathing berm, or picnic within an airy park shelter. For those looking for more activity, a new zero-depth splash pad, tennis and pickleball courts, playground, and skate park provide plentiful opportunities.

The park was also designed to accommodate winter use, with the bathhouse lobby converting into a warming shelter in cold weather, the circular vehicular drop-off zone transforming into a recreational ice skating venue, and a separate area designated as a place to host low-board hockey. The community celebrated the grand opening of the aquatic center on July 1, 2020.

WEST SIDE PARK AND LEONARD-LEOTA PARK IMPROVEMENTS | EVANSVILLE, WI



MSA was selected to provide master planning and design services for a dual park upgrade in Evansville, introducing a new public aquatic center, splash pad, ball diamonds, and a range of park enhancements. The design was completed in collaboration with Water Technology, Inc. (WTI) as the aquatics/splash pad designer and Rettler Corporation as the athletic fields specialist.

Evansville Aquatic Center: The new facility replaced a deteriorating pool at Leonard-Leota Park and was relocated to a 24-acre site now known as Larson Acres Park. Designed for all ages and abilities, the center features a six-lane pool, aqua climbing wall, diving board, lazy river, basketball hoops, water slides, zero-depth entry, spray geysers, and shaded lounging areas. The bath house includes admissions, restrooms, concessions, locker rooms, lifeguard support, and mechanical spaces, with an adjacent pool equipment building offering reservable gathering areas.

Larson Acres Park: The surrounding park improvements include a new drive with community gardens, parking, and drop-off access, along with upgraded soccer and ball fields, a multisport court, open green space, and accessible trails. Stormwater systems were designed to meet WDNR requirements and support site sustainability.

Leonard-Leota Park Splash Pad: With the former pool decommissioned, MSA designed a tiered splash pad overlooking the park's 40-acre steam-fed lake. The flow-through pad features interactive water elements and zero-depth entry for all ages and abilities, surrounded by new patios and a refurbished parking area, with future plans for a lake-view community room.

The Evansville Aquatic Center and dual-park improvements reflect our ability to deliver inclusive, multigenerational recreation spaces that align with long-term community goals. This project showcases our expertise in integrating aquatic design, park planning, and site infrastructure to create vibrant destinations that foster wellness, connectivity, and civic pride.

- Site Size: 9.7 acres
- Pool Surface Area: 8,917 sf

Project Timeline/Schedule

- Design: August 2021 - April 2022
- Construction: August 2022 - May 2024

Architect/Engineer Estimate: \$12,900,000

Awarded Bid and Final Cost

Awarded: \$13,452,486 | Final: \$13,462,699

**** Increase due to the volatile bidding market in 2022 and only two bidders.**

Client Reference

Jason Sergeant, City Administrator
(608) 882-2285 | j.sergeant@ci.evansville.wi.gov

Project Outcome

The Evansville dual park upgrades delivered a transformative recreation experience, replacing aging infrastructure with vibrant, inclusive amenities that serve residents of all ages and abilities. The new aquatic center, splash pad, athletic fields, and accessible park features have enhanced community well-being, supported active lifestyles, and created year-round destinations for gathering and play. As a result, Evansville has strengthened its identity as a welcoming and desirable place to live within the greater Madison and Janesville areas, using the facilities to foster civic pride, attract regional visitors, and support ongoing recreational programming.

Project Team to Work on Your Project

E. Carter Arndt, Matt Freeby, Dan Rammer, Taylor Turnquist, Marcus Rue

ERB PARK AND SWIMMING POOL

APPLETON, WI



The former outdoor Erb Pool facility and park shelter were in desperate need of replacement. The opportunity was seized by the City to master plan a full park improvement project for this very important and long-standing \$10 million park investment.

MSA's highly qualified parks team developed the overall park concept and was selected as the "most creative and comprehensive" for the project. Master park planning ensued with a series of public and City meetings to develop a dynamic design to improve the park in every way possible. Though the facility serves as a City-wide amenity, the team was careful to maintain a "special neighborhood park" feel due to its location surrounded by residential properties.

The new aquatics facility includes an eight-lane competitive Olympic-size pool, the only one in the region, complemented by a 6,200-square-foot recreational pool with zero-depth entry, slides, and other water features. It also includes a large run-out body slide and tower, shade structures, birthday party areas, sun turf, and a concessions area, making it a standout community aquatic feature.

Park amenities include new concrete and asphalt multiuse paths/sidewalks, grilling stations, all-new parking lots, basketball and tennis courts, a multiuse sports field, a sledding hill, an ice skating area, and a playground with pour-in-place rubber surfacing. Additional features include new landscaping, ping pong tables, bean bag toss stations, ample bike racks, and new park and pool furnishings. Challenging stormwater needs were met through an intricate computer model with infrastructure, infiltration, and a pond with a water fountain.

Buildings include a bath house with an octagon main lobby/admissions space, staff areas, a multipurpose room that serves as a warming shelter in winter, and a professionally designed concessions stand serving both the pool and the park. Natural daylighting features provide substantial illumination for the facility. Other buildings include a freestanding pool equipment structure with a covered seating area and a pavilion park shelter with restrooms and an event support kitchen.

The Erb Park improvements demonstrate our ability to deliver large-scale, community-driven park and aquatic facility transformations that balance regional appeal with neighborhood charm. MSA's creative design integrated competitive aquatics, diverse recreation amenities, and sustainable infrastructure to revitalize this beloved Appleton destination.

- Site Size: 27.25 acres
- Pool Surface Area: 6,200 sf

Project Timeline/Schedule

- Design: February 2016 - July 2017
- Construction: August 2016 - July 2017

Architect/Engineer Estimate: \$9,739,000

Awarded Bid and Final Cost

Awarded: \$8,757,842 | Final: \$9,025,824

**** Change in cost primarily associated with Owner initiated changes and the total budget was less than the A/E estimate (with-in City budget).**

Client References

Dean Gazza, Director of Parks and Recreation
(920) 832-5572 | dean.gazza@appltion.org

Tom Flick, Deputy Director of Parks and Recreation
(920) 832-3915 | tom.flick@appleton.org

Project Outcome

The Erb Park project revitalized a key community asset, transforming it into a regional destination while preserving its neighborhood charm. The City of Appleton leveraged the results to enhance year-round recreation, increase public engagement, and showcase its commitment to inclusive, high-quality park and aquatic infrastructure.

Project Team to Work on Your Project

E. Carter Arndt, Matt Freeby

SWAN PARK AND SPLASH PAD

BEAVER DAM, WI



Pool Surface Area: 6,800 SF

This project demonstrates our ability to revitalize aging public assets through phased, community-driven design, delivering inclusive aquatic and park spaces that reflect long-term municipal goals.



SUNSET POOL

ELKHORN, WI



Pool Surface Area: 7,413 SF

This project reflects our ability to replace aging aquatic infrastructure with modern, multigenerational amenities that reinvigorate community parks and drive high public use.

Pool Surface Area: 7,413 SF



MSA SELECT AQUATIC CENTER/POOL EXPERIENCE

- Erb Park and Swimming Pool, Appleton, WI
- Aquatics Assessment Study, De Pere, WI
- West Side Park and Leonard-Leota Park Improvements and Splash Pad, Evansville, WI
- Municipal Pool Facility, Lodi, WI
- Aquatics Assessment Study, Baraboo, WI
- Baraboo School District Indoor Pool Addition, Baraboo, WI
- Aquatics Assessment Study, Reedsburg, WI
- Christmas Mountain Village Check-in/Pool Building, Wisconsin Dells, WI
- Swan Park Splash Pad, Beaver Dam, WI
- Irwin A. and Robert D. Goodman Community Pool, Madison, WI
- Municipal Pool Facility, Muscoda, WI
- Sunset Pool Facility, Elkhorn, WI
- Recreation Complex and Aquatic Center, Wisconsin Rapids, WI
- Aquatic Park at Witter Field, Wisconsin Rapids, WI
- Aquatics Center Conceptual Study, Frederic, WI
- Aquatics Assessment Study, Dubuque, IA

WTI SELECT AQUATIC FACILITY EXPERIENCE

- Erb Park Pool, Appleton, WI
- Kaukana Municipal Swimming Pool Evaluation, Kaukauna, WI
- Creekview Aquatic Center at the Evergreen Retirement Community Oshkosh, WI
- Downtown Community YMCA, Oshkosh, WI
- Oshkosh Community YMCA at 20th Avenue, Oshkosh, WI
- Polluck Community Waterpark, Oshkosh, WI
- VFW Aquatic Center, De Pere, WI

- Ashwaubenon Community Pool, Ashwaubenon, WI
- Fond du Lac Family YMCA, Fond du Lac, WI
- Green Bay Colburn Pool, Green Bay, WI
- Green Bay East YMCA, Green Bay, WI
- Joannes Family Aquatic Center, Green Bay, WI
- The Tundra Lodge Resort & Waterpark, Green Bay, WI
- Salvation Army Ray & Joan Kroc Corps Community Center, Green Bay, WI
- Manitowoc Family Aquatic Center, Manitowoc, WI
- Baldwin Medical Center, Baldwin, WI
- Port Superior Marina, Bayfield, WI
- YMCA of Dodge County, Beaver Dam, WI
- VFW Aquatic Center, De Pere, WI
- Fairfax Pool Renovation, Eau Claire, WI
- Sunset Pool Replacement, Elkhorn, WI
- Elm Grove Western Raquet Club Design, Elm Grove, WI
- Evansville Aquatic Center at Larson Acres Park, Evansville, WI
- Kinderberg Park Splashpad, Germantown, WI
- Village Pointe Commons, Grafton, WI
- Signicast Family Aquatic Center, Hartford, WI
- Horicon Aquatic Center, Horicon, WI
- Iola-Scandinavia Community Fitness & Aquatic Center, Iola, WI
- Marshall Middle School, Janesville, WI
- Jefferson High School, Jefferson, WI
- Kohler Outdoor Zero Depth Pool, Kohler, WI
- Kohler Riverbend Spa, Kohler, WI
- Kohler Water Spa at the American Club, Kohler, WI
- Erickson Park Pool, La Crosse, WI
- La Crosse Area YMCA - La Crosse



PROJECT UNDERSTANDING

The City of Menasha is a vibrant, growing Fox River Valley community in need of a replacement outdoor aquatics facility. Menasha's motto, "Your Place on the Water," reflects its identity as a welcoming waterfront city with a strong connection to Lake Winnebago and the Fox River.

On October 20, 2025, the Menasha City Council approved the permanent closure of the existing aquatic facility due to its physical condition and the desire to build a new one. For the good of the community, the goal is to have a new facility ready for the 2027 outdoor swim season. A demolition project is targeted for spring 2026, with construction to follow.

The aquatic facility is located in Jefferson Park, the City's signature 29-acre waterfront park that serves as both a community gathering place and a regional recreation destination. The new facility is projected to be built in the same general location as the current pool. While the City does not plan to reuse any of the existing infrastructure, it may consider preserving select historical elements.

Replacing the pool with a state-of-the-art aquatic facility supports the goals of the City's Vision Plan and ongoing reinvestment in Jefferson Park. It reinforces the park's role as a community hub and provides a high-quality recreational experience for all ages and abilities.

The project budget, aquatic amenity mix, bathhouse, concessions, parking, and site development will all be considered and refined during the visioning and planning process. The total construction cost is estimated to be between \$10 million and \$15 million.

*Designed for Menasha.
Inspired by Water. Built for All.*

The City's intent for the project includes reflecting the Jefferson Park Master Plan, responding to community and stakeholder input, balancing recreation and water safety programming, enhancing accessibility and universal design, advancing environmental and financial sustainability, and integrating thoughtful site planning.

PROJECT APPROACH

Our team is prepared to support this critical need on the accelerated timeline it requires. With a combined workforce of nearly 500 engineers, architects, designers, and associated professionals, we have the capacity to meet the City's goals. This project follows a similar timeline to the successful Appleton Erb Park and Pool project, which was led by the same team. Please reference the Milestone Schedule, where we have given special thought to the initial timeline and outlined strategies for proceeding efficiently. These include prompt exploration of fast-track options such as a potential pre-award A/E meeting in November, initiating site surveying this fall, developing a standalone demolition package, and considering the use of a Construction Manager (not at risk) to expedite bidding and construction.

The City's aquatic facility RFP outlines a detailed scope of services for all phases of the project. See the Graphic Process Summary on the following page.

Phase 1 will be initiated at this time, and the associated scope of services is included.



Menasha 2035 refers to the City of Menasha's 10-year comprehensive plan update, titled "Your Place on the Water." It is a strategic guide to the city's growth and development, focusing on strengthening neighborhoods, prioritizing redevelopment opportunities, and improving zoning. Key areas of focus include downtown revitalization, the Water Street corridor, and better use of the city's waterfront and canal system.

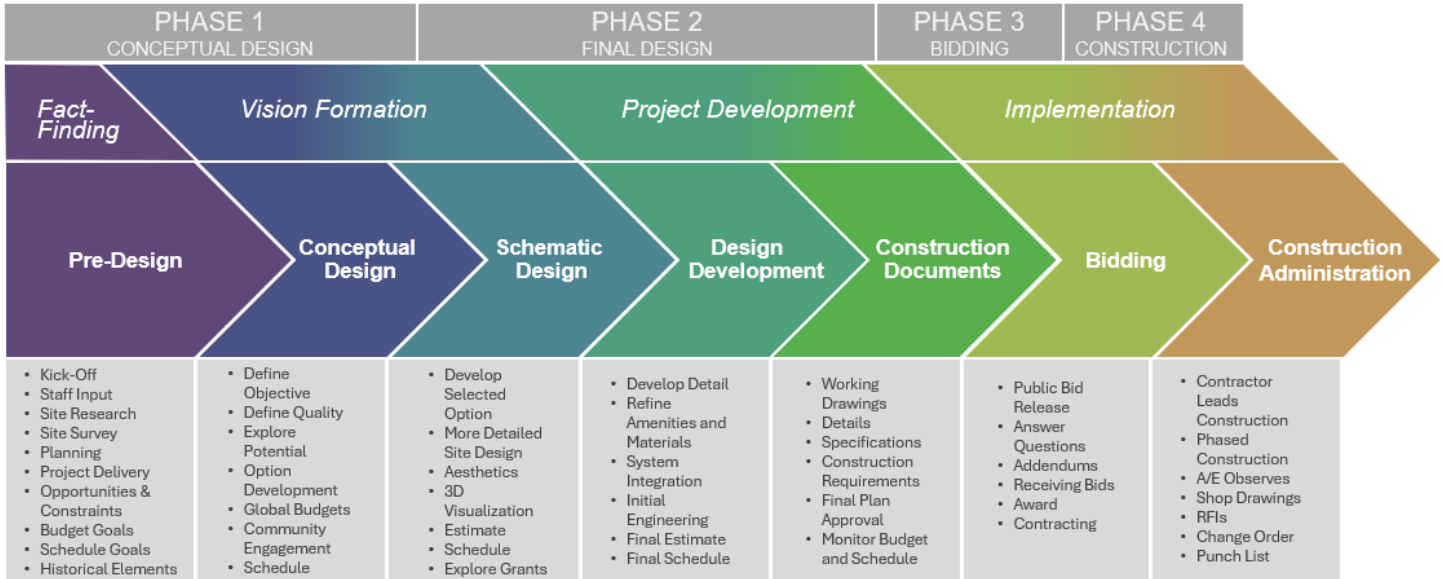

PHASE 1: CONCEPTUAL DESIGN

The selected consultant will be responsible for delivering professional design services, including but not limited to:

- Conduct a Phase 1 Kickoff Meeting with City staff.
 - Review big picture goals, stakeholders, and community engagement options.
 - Gather existing information on the park and perform a site visit.
- Develop a community engagement strategy to solicit and consolidate input from a variety of constituents, including Park Board members, staff, and the general public.
 - Design and facilitate a minimum of one public outreach meeting to receive community input regarding current and future demand for aquatic programs and facilities.
 - Gather information on types of amenities to include in the Aquatic Facility, ranging from pool features to facility features.
 - Gather information on obstacles and opportunities within the park.
- Conduct Programming Workshops (aquatics, site, building(s),
 - Full Day session with City staff and stakeholders as needed.
- Develop three concepts to be presented at a public meeting, then presented to the Park Board (*the public input meeting and presentation to the Park Board will be held on the same evening*). Each concept will include: 3-dimensional massing rendering of the Aquatic Facility, 2-dimensional drawing of park layout, 2-dimensional drawing of the Aquatic Facility, a listing of Aquatic Facility amenities,
- Budget estimate to include all capital costs associated with the project.
- From feedback from public input and Park Board meetings, develop one option to be presented to the Park Board and Board of Public Works (*Park Board and Board of Public*

Works will likely be held on different evenings).

- Final concept will include: 3-dimensional rendering of the Aquatic Facility, 2-dimensional architectural drawing of the Aquatic Facility highlighting amenities and building layout, itemized budget projection to include all capital costs associated with the project, and a projected operational and maintenance budget.
- Review existing parking based on the proposed Aquatic Facility layout, develop the proposed master site plans, and have a meeting to review with staff and refine.
- Make final changes or alterations to the Aquatic Facility layout. Final concept will include: 3-dimensional rendering of the Aquatic Facility, 2-dimensional drawing of an Aquatic Facility based on location and impacts to existing facilities in the park, 2-dimensional architectural drawing of the Aquatic Facility highlighting amenities and building layout, 2-dimensional overall site drawing of the Aquatic Facility highlighting facility amenities and building layout, and an itemized budget projection to include all costs associated with project including utilities to service the new Aquatic Facility with an expectation to utilize existing utilities where possible to minimize costs.
- Actively identify, recommend, and assist with the preparation and submission of applications for applicable grants.
- If desired, a Public and/or City Board Meeting to present the preliminary design.
- Deliverables per the City RFP.

Phase 1 Meetings

The Consultant shall plan to attend the following meetings, including but not limited to those listed below. Meetings may be held in person or virtually, unless otherwise specified.

- Kick-off Meeting
- In-person Programming Workshop
- In-person Public Engagement Meeting

- In-person presentations to the Park Board and Board of Public Works
- Meetings with staff for feedback and decisions.

OPTIONAL ADDITIONAL PHASE 1 SERVICES

Demolition Bid Package

- **Design/Technical Phase**
 - Meeting and coordination with the City.
 - Observe existing conditions.
 - Prepare Plan Set containing Drawings and Project Specifications Manual, including Title Sheet, Existing Site Plan from Aerial, Demolition Plan based on existing amenities, details for backfilling pool, and pool house area.
- **Bidding Phase**
 - Prepare Advertisement for Bids and forward to the Village for publishing in the local newspaper (advertising costs to be paid by the City).
 - Electronic distribution of drawings and specifications, virtual bid opening via Quest.
 - Answer bid questions and issue addendums as needed.
 - Electronic review and evaluation of bids. Provide a recommendation on the award of the project bid.
 - Develop the Owner/contractor Agreement for processing.
- **Construction Phase**
 - Virtually attend preconstruction conference.
 - Three site visits.
 - Answer questions and issue clarifying information.
 - Excludes site survey and hazardous material identification, testing, and reporting.

Asbestos Testing and Review

- Virtual meeting with Owner.
- Site visit, sampling, and sample testing.
- Report preparation.

Site Topographic Survey

- Virtual meeting with Owner.
- Field Work and Survey Drawing: Architectural topographic survey with site features, adjacent roadway, and property lines, and nearby park structures.

OTHER SERVICES TO FOLLOW

Under A Separate Agreement

Our team shall provide the following professional services:

- Project leadership, coordination, scheduling, budgeting, and permitting/approvals.
- Site/civil engineering.
- On-site stormwater engineering.
- Utility laterals.
- Landscape design, including:
 - Site irrigation for areas inside the pool fence enclosure.
 - Site and aquatics furnishings design.
 - Limited landscape planting as directed by the City.
- Architectural design and documentation.
- Structural engineering.
- Aquatics design and engineering.
- Mechanical/electrical/plumbing engineering.
- General site lighting.
- Aquatics sound system and aquatics lighting.
- Coordination of future security camera system (rough-in only).

PHASE 2: TECHNICAL DESIGN/ENGINEERING

Would typically include a Food Service Sub-Consultant for concessions planning and design.

PHASE 3: BIDDING

PHASE 4: CONSTRUCTION ADMINISTRATION

A Pool With Purpose: Built for Belonging, Safety, and Shared Joy.

DESIGNING FOR EVERYONE

As part of MSA’s commitment to community-centered design, our team structure reflects a deep understanding of the difference between accessibility and inclusivity, principles that guide our approach to aquatic, park, and playground planning.

Inclusivity goes beyond accessibility by focusing not just on physical access, but on meaningful participation for all members of the community. While accessibility removes physical barriers, inclusivity creates environments where children and families of all abilities can connect, play, and grow together.

MSA understands that inclusive design must consider the full spectrum of developmental needs: physical, sensory, cognitive, and

social-emotional. Our approach emphasizes creating emotionally and socially supportive spaces that invite everyone to engage, not just enter. By designing with the whole community in mind, we help foster a sense of belonging and shared experience. True inclusion happens when every person feels welcomed, valued, and able to participate fully in the joy of outdoor play.

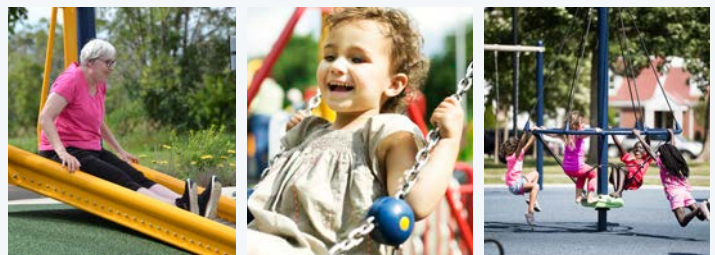

2025		
	November	City Makes Tentative A/E Selection
	Mid/Late November	Pre-Agreement Initial Big Picture Meeting <i>(with no obligation and at no cost to City)</i> <ul style="list-style-type: none"> Discuss Initial Varied FAST-TRACK Approaches to Target 2027 Opening: <ul style="list-style-type: none"> <i>Optional:</i> Topographic Site Survey <i>Optional:</i> Separate Bid Package for Demolition <i>Optional:</i> Asbestos Review Phase 1 Conceptual Design Discuss Construction Manager not-at-risk Option for FAST-TRACK (by others)
	Late November	MSA Provides Formal Agreement for Potential City Action
	December 1 st	City/Final Consultant Selection and Agreement Approval
DEMOLITION PROJECT		AQUATIC PARK PROJECT
Start Optional Demolition Design	Early December	Start Conceptual Design - Kick-off Meeting
	Early December	Optional - Start Site Survey Work
	Mid December	Optional - City Release of CM RFP
	Mid-December	FULL Programming Meeting
2026		
	Early January	Meeting Rough Master Park Concepts
On-Going Progress Meetings	February	On-Going Iterations and Meetings
	Mid-February	Complete Conceptual Design
	Late February	Start Technical Design (Remaining A/E Services Agreement In Place)
Demolition Bid Package Completion Release for Bidding	March	
Electronic Bid Opening	April	
Bid Award – Contract in Place	May	
	Early June	Complete Technical Design (Certain FAST-TRACK Bids may occur earlier or later) Release for Bidding
Demolition Start	Late June	Electronic Bid Opening
Demolition Complete	July	Bid Award – Contract in Place
	Late July	Construction Start
2027		
	Late May	State Pool Inspection (no later than)
	Early June	Substantial Completion
	Early June	City Takes occupancy
	Mid-June	Targeted Opening

Note:

1. This schedule is targeting the perceived desire for a Spring 2027 opening. This schedule is accordingly aggressive.
2. As the project proceeds, more milestones will be added and the exact dates established.
3. The less aggressive alternative schedule would bid the project out later in 2026 and have a completion in May 2028. This would allow more time for the following: City decision making, community feedback, A/E option exploration/design development, longer construction window and City facility readiness earlier in the first season.
4. MSA will generate monthly City updates to communicate ongoing progress and design developments, with optional web site page for the community access desired.



IT'S MORE THAN A PROJECT. IT'S A COMMITMENT.

JEFFERSON PARK AQUATIC FACILITY DESIGN
MENASHA, WI | OCTOBER 27, 2025



www.msa-ps.com





Fee Proposal Jefferson Park Aquatic Facility Design
City of Menasha | October 27, 2025

*More Than A Pool,
A Community Anchor for All Ages.*



FEE PROPOSAL

The Lump Sum (not to exceed) cost for Phase 1 Conceptual Design (base) professional services is **\$78,000**.

MSA welcomes the opportunity to discuss any desired customization, prioritization and/or phasing of the project scope that will meet the goals and expectations necessary for this project.

Comments:

1. Fee Includes all anticipated reimbursables.
2. Per the RFP, this fee does not include Phase 2 – Technical Design, Phase 3 – Bidding, and Phase 4 – Construction Administration Services and other Optional Phase 1 services as identified by MSA.
3. To accommodate an expeditious schedule, MSA is offering Optional Supplemental Phase 1 Services as listed below:

SUMMARY OF PHASE 1 PROFESSIONAL SERVICES		LUMP SUM FEE
Conceptual Design (Base) Services		\$78,000
Optional Supplemental Services		
	Topographic Site Survey	Add: \$8,800
	Demolition Bid Package (Technical Design, Bidding, and Construction Administration)	Add: \$29,000
	Review of existing asbestos, sampling and testing of the existing facility and summarizing report (for inclusion in the demolition bid package)	Add: \$3,500

PHASE 1 CONCEPTUAL DESIGN (BASE) SERVICES - FEE DISTRIBUTION SUMMARY					
APPROX. %	NAME	JOB CLASSIFICATION/OTHER	HOURLY RATE	HOURS	TOTAL
24%	E. Carter Arndt	Project Architect/Manager	\$200	94	\$18,800
16%	Justine Good	Architectural Designer	\$160	80	\$12,800
5%	Kevin Byrne	Landscape Architect	\$200	20	\$4,000
2%	Marcus Rue	Parks Civil Engineer	\$200	8	\$1,600
5%	Dan Rammer	Civil Engineer, Client Liaison	\$200	17	\$3,400
1%	Brittney Mitchell	Grant Funding Specialist	\$155	6	\$930
4%		Civil Tech	\$140	20	\$2,800
1%		Administration Assistant	\$110	4	\$440
		MSA Reimbursables (Copies, Mileage & Travel Expenses)			\$1,160
	MSA Subtotal			249	45,930.00
22%	Matt Freeby	Project Director	\$250	68	\$17,000
18%	Taylor Turnquist	Project Designer	\$145	96	\$13,920
1%		Mechanical Designer	\$170	2	\$340
1%		Administration Assistant	\$75	2	\$150
		WTI Reimbursables (Copies, Mileage & Travel Expenses)			\$660
	WTI Subtotal			168	\$32,070
100%	Grand Total			417	\$78,000

IT'S MORE THAN A PROJECT. IT'S A COMMITMENT.

JEFFERSON PARK AQUATIC FACILITY DESIGN FEE PROPOSAL

MENASHA, WI | OCTOBER 27, 2025



www.msa-ps.com



**City of Menasha Disbursements
12/12/25-12/31/25**

Weekly Accounts Payable	12/18/25, 12/19/25, 12/23/25 & 12/31/25 Checks # 89271-89412	\$808,750.76
Bi-Weekly Payroll	12/24/25	\$257,496.74
Additional Regular Cycle Accounts Payables -Paid Electronically		
Wisconsin Deferred Compensation	12/12/25	\$11,335.75
Employee Benefits-Flex Spending	12/12/25	\$3,207.43
Community First CU-Payroll Deduction	12/12/25	\$763.60
Network Health Premium	12/15/25	\$163,276.01
Delta Dental	12/16/25	\$3,255.21
Primedata ACH	12/16/25	\$4,699.29
Federal Tax Withholding	12/17/25	\$75,893.79
US Bank ACH	12/17/25	\$224.02
US Bank ACH	12/17/25	\$76.98
Sugar Maple Properties ACH	12/17/25	\$3,200.00
Spectrum ACH	12/17/25	\$80.00
Home Depot ACH	12/22/25	\$49.80
Home Depot ACH	12/22/25	\$299.00
Sales Tax	12/23/25	\$138.10
Delta Dental	12/24/25	\$1,125.32
Nationwide Deferred Compensation	12/24/25	\$3,487.50
Civic Plus ACH	12/24/25	\$4,404.75
Wisconsin Support Collections	12/24/25	\$823.91
Community First CU-Payroll Deduction	12/24/25	\$763.60
Wisconsin Deferred Compensation	12/26/25	\$11,335.75
State Tax Withholding	12/26/25	\$18,289.73
Employee Benefits-Flex Spending	12/26/25	\$3,207.43
State Tax Withholding	12/30/25	\$15,775.08
Federal Tax Withholding	12/31/25	\$63,577.08
FSA/HRA Admin Fees	12/31/25	\$632.05
Employee Trust Funds (WRS)	12/31/25	\$157,874.65
Delta Dental	12/31/25	\$2,262.90
		<u>\$538,722.98</u>
Total		<u><u>\$1,604,970.48</u></u>

Items included on this list have been properly audited and certified by the City Finance Director and are being presented for approval by the Common Council.

Yessi Laracuenta
Yessi Laracuenta
Finance Manager

12/31/25
Date

Notes:
- Gaps in check numbers indicate that more invoices being paid than fit on one check stub
(The last check stub used is the check number that will appear on the check register)

AP Check Register

Check Date: 12/18/2025

Vendor Name	Check Number	Check Date	Invoice Number	Account Number	Amount	Description
AMAZON CAPITAL SERVICES	89271	12/18/2025	16VM-P61F-333L	100-0920-531.30-18	12.73	CARDSTOCK-MSC PROGRAM
		12/18/2025	1HDL-JW3V-DHHX	100-0702-552.30-10	57.97	OFFICE SUPPLIES-PR
				100-0702-552.30-18	501.50	CRAFTS/SUPPLIES-PR
	12/18/2025	1J67-TC4H-GQWH	100-0804-521.30-15	64.05	DIGITAL WALL CLOCK, NAMEPLATE HOLDER	
	12/18/2025	1KKC-JPCV-HLNN	100-0801-521.30-10	170.18	WOOD PAPER ORGANIZER, SMALL COMPUTER DESK	
	12/18/2025	1MYQ-FLTX-16H3	100-0702-552.30-18	22.99	TEA LIGHT CANDLES -HOLIDAY HAYRIDE	
				100-0920-531.30-18	131.21	MSC GRINCH CRAFT
	12/18/2025	1Q1W-XGMY-7PDH	100-0702-552.30-10	44.88	PENS, CALENDAR, BROCHURE HOLDER	
				100-0702-552.30-18	89.98	HEAVY DUTY UTILITY CART
				100-0920-531.30-10	42.75	OFFICE CHAIR MAT
	12/18/2025	1QJF-WVL3-C36J	100-0203-512.30-10	13.49	INDEX CARDSTOCK	
	12/18/2025	1QNR-K6MK-DF1J	100-0702-552.30-18	29.99	BEAN BAGS	
				100-0920-531.30-10	17.83	PAPER CLIPS, RUBBER BANDS
				827-0920-531.30-18	19.94	DISHWASHER PODS
	12/18/2025	1WTW-7CLD-CPVR	100-0202-512.30-10	89.88	OFFICE SUPPLIES	
				100-0202-512.30-21	57.19	OFFICE SUPPLIES
	12/18/2025	1YMG-76GT-J3TW	100-0801-521.29-01	32.62	HANGING FILE ORGANIZER	
	12/18/2025	1YX1-YXXY-JDJF	100-0801-521.34-04	109.99	PROFESSIONAL SHOT TIMER FOR SHOOTING COMPETITI	
			Total for check: 89271	1,509.17		
ASSOCIATED APPRAISAL CONSULTANTS	89272	12/18/2025	183629	100-0402-513.21-09	153.96	INTERNET POSTING-PARCELS
					6,666.67	DEC-ASSESSMENT SERVICES
				100-0402-513.30-11	75.48	POSTAGE
			Total for check: 89272	6,896.11		
BAYCOM INC	89273	12/18/2025	EQUIPINV_059202	100-0801-521.30-15	258.00	MOLLE MOUNT/KIT
			Total for check: 89273	258.00		
BERGSTROM FORD LINCOLN	89274	12/18/2025	113923	731-1022-541.38-04	104.60	FUEL TANK
			Total for check: 89274	104.60		
CELLCOM	89275	12/18/2025	503906	100-0101-511.22-01	34.13	CELL PHONE -MAYOR

AP Check Register

Check Date: 12/18/2025

Date: 12/30/2025

Vendor Name	Check Number	Check Date	Invoice Number	Account Number	Amount	Description
CELLCOM...	89275...	12/18/2025...	503906...	100-0201-512.22-01	34.13	CELL PHONE -ATTORNEY
				100-0203-512.22-01	34.13	CELL PHONE -CLERK
				100-0301-523.22-01	34.13	CELL PHONE -BUILDING INSPECTOR
				100-0304-562.22-01	68.26	CELL PHONE -COMMUNITY DEVELOPMENT
				100-0401-513.22-01	34.13	CELL PHONE -FINANCE
				100-0601-551.22-01	23.21	CELL PHONE -BUILDING SERVICES
					75.51	CELL PHONE -LIBRARY
				100-0702-552.22-01	222.70	CELL PHONE -PARK LOCATIONS
				100-0703-553.22-01	13.65	CELL PHONE -BUILDING SERVICES
					181.96	CELL PHONE -PARKS
				100-0801-521.22-01	15.70	CELL PHONE -BUILDING SERVICES
					1,748.15	CELL PHONE -POLICE
					(0.01)	CELL PHONE -POLICE
				100-0811-521.22-01	34.13	CELL PHONE -CODE ENFORCEMENT
				100-0904-531.22-01	34.13	CELL PHONE -ENVIRONMENTAL HEALTH
				100-0919-531.22-01	245.49	CELL PHONE -HEALTH
				100-1001-514.22-01	15.70	CELL PHONE -BUILDING SERVICES
				100-1002-541.22-01	148.55	CELL PHONE -ENGINEERING
				100-1008-541.22-01	15.70	CELL PHONE -STREET SIGNS
				100-1019-552.22-01	14.50	CELL PHONE -BRIDGES
				601-1020-543.22-01	7.25	CELL PHONE -SEWER TRUCK
				625-1002-541.22-01	49.52	CELL PHONE -ENGINEERING
				731-1022-541.22-01	137.19	CELL PHONE -CITY GARAGE
				743-0403-513.22-01	68.26	CELL PHONE -IT
Total for check: 89275					3,290.20	
CHARTER COMMUNICATIONS	89276	12/18/2025	095528601120125	100-0101-511.22-01	3.42	PHONE BILL-MAYOR
				100-0201-512.22-01	2.17	PHONE BILL-ATTORNEY
				100-0202-512.22-01	5.49	PHONE BILL-PERSONNEL
				100-0203-512.22-01	4.51	PHONE BILL-CLERK
				100-0301-523.22-01	4.95	PHONE BILL-BUILD INSPECT
				100-0304-562.22-01	8.12	PHONE BILL-COM DEV
				100-0401-513.22-01	10.96	PHONE BILL-FINANCE
				100-0402-513.22-01	2.23	PHONE BILL-ASSESSOR

AP Check Register
Check Date: 12/18/2025

Date: 12/30/2025

<i>Vendor Name</i>	<i>Check Number</i>	<i>Check Date</i>	<i>Invoice Number</i>	<i>Account Number</i>	<i>Amount</i>	<i>Description</i>
CHARTER COMMUNICATIONS...	89276...	12/18/2025...	095528601120125...	100-0502-522.22-01	13.60	PHONE BILL-EOC
				100-0601-551.22-01	57.73	PHONE BILL-LIBRARY
				100-0702-552.22-01	9.18	PHONE BILL-RECREATION
				100-0703-553.22-01	15.43	PHONE BILL-PARKS
				100-0704-552.22-01	4.79	PHONE BILL-POOL
				100-0801-521.22-01	85.13	PHONE BILL-POLICE
				100-0903-531.22-01	16.66	PHONE BILL-HEALTH
				100-0920-531.22-01	4.48	PHONE BILL-SENIOR CTR
				100-1001-514.22-01	24.58	PHONE BILL-CITY HALL
				100-1002-541.22-01	14.31	PHONE BILL-ENGINEERING
				100-1008-541.22-01	1.29	PHONE BILL-SIGN
				207-0000-123.00-00	9.12	PHONE BILL-MARINA
				731-1022-541.22-01	8.82	PHONE BILL-GARAGE
				743-0403-513.22-01	5.21	PHONE BILL-I.T.
				Total for check: 89276		
CINTAS	89277	12/18/2025	4252805586	100-0703-553.24-03	439.49	MATS, UNIFORMS, CLEANING SUPPLIES
				731-1022-541.20-01	161.00	MATS, UNIFORMS, CLEANING SUPPLIES
					200.00	MATS, UNIFORMS, CLEANING SUPPLIES
				100-0801-521.20-01	50.25	MATS, SOAP, BAGS
				100-0801-521.30-13	151.45	MATS, SOAP, BAGS
				100-0601-551.20-01	48.00	RUGS, CLEANING SUPPLIES, BAGS
				100-0601-551.30-13	219.20	RUGS, CLEANING SUPPLIES, BAGS
Total for check: 89277					1,269.39	
CIVICPLUS LLC	89278	12/18/2025	357442	100-0405-513.21-08	75.62	MEETING RECORDING- CLOSED CAPTIONING
				Total for check: 89278		
CJR TOOLS LLC	89279	12/18/2025	12082531900	731-1022-541.24-02	92.25	TOOL REPLACEMENT
				Total for check: 89279		

AP Check Register

Check Date: 12/18/2025

<i>Vendor Name</i>	<i>Check Number</i>	<i>Check Date</i>	<i>Invoice Number</i>	<i>Account Number</i>	<i>Amount</i>	<i>Description</i>
COONEY'S EMBROIDERY LLC	89280	12/18/2025	22718	100-0801-521.19-02	103.00	POLO'S, JACKETS
			Total for check: 89280		103.00	
EAGLE SIGN & DESIGN	89281	12/18/2025	19143	100-0703-553.29-01	429.00	BOAT PERMITS 2026
			Total for check: 89281		429.00	
ENGBERG ANDERSON ARCHITECTS	89282	12/18/2025	25390700-2	100-0304-562.21-02	580.00	COMP PLANNING SERVICES PROJECT #253907.00
			Total for check: 89282		580.00	
EVERGREEN POWER	89283	12/18/2025	29404	731-1022-541.38-03	99.45	OREGON BLADE
			Total for check: 89283		99.45	
FACTORY MOTOR PARTS CO	89284	12/18/2025	18-2329408	731-1022-541.38-03	19.74	OIL FILTER
		12/18/2025	18-Z34893	731-1022-541.38-03	158.81	BATTERY CORE
			Total for check: 89284		178.55	
FOX VALLEY TRUCK	89285	12/18/2025	547460	100-1006-541.30-15	1,767.96	PLOW BLADES
			Total for check: 89285		1,767.96	
GREAT BIG GRAPHICS LLC	89286	12/18/2025	11564	100-0801-521.29-01	83.00	BUSINESS CARDS
			Total for check: 89286		83.00	
CLAIRE HOLZSCHUH	89287	12/18/2025	MILEAGE	100-0903-531.33-01	16.03	OCT-DEC 2025 MILEAGE
				100-0903-531.33-04	9.70	OCT-DEC 2025 PARKING
			Total for check: 89287		25.73	
INTOXIMETERS INC	89288	12/18/2025	803148	100-0801-521.30-15	1,780.00	OFFICER EQUIP/SUPPLIES
			Total for check: 89288		1,780.00	

AP Check Register

Check Date: 12/18/2025

Vendor Name	Check Number	Check Date	Invoice Number	Account Number	Amount	Description
JX ENTERPRISES INC	89289	12/18/2025	24135601P	731-1022-541.38-03	368.20	STUD/NUT WHEELS
			Total for check: 89289		368.20	
KLINK HYDRAULICS LLC	89290	12/18/2025	JG630	731-1022-541.38-03	11.04	T-BOLT CLAMP
		12/18/2025	TV1560	731-1022-541.38-03	227.00	HYDRAULIC FITTING PARTS
		12/18/2025	TV1593	731-1022-541.38-03	313.83	HOSE
			Total for check: 89290		551.87	
LAMERS BUS LINES INC	89291	12/18/2025	BUS TRIP	100-0000-201.14-00	1,450.00	BEEHIVE BUS TRIP-2/1/26
					1,450.00	HAIRSPRAY BUS TRIP-5/3/26
					1,450.00	CHRISTMAS STORY BUS TRIP -11/15/26
			Total for check: 89291		4,350.00	
MATTHEWS TIRE INC	89292	12/18/2025	100066	731-1022-541.38-02	1,242.00	VALVE STEM/TIRES
			Total for check: 89292		1,242.00	
MENARDS-APPLETON EAST	89293	12/18/2025	86950	731-1022-541.30-18	63.73	MAILBOX
			Total for check: 89293		63.73	
MENASHA NEENAH MUNICIPAL COURT	89294	12/18/2025	REPORT #25-0157	100-0000-201.03-00	300.00	REPORT #25-0157
			Total for check: 89294		300.00	
MENASHA UTILITIES	89295	12/18/2025	MENASHA UTIL.	100-0000-123.00-00	777.66	10/29/25-11/26/25-ELEC
					296.34	10/29/25-11/26/25-WAT/SEW
					77.69	10/29/25-11/26/25-STORM
					9.67	10/29/25-11/26/25-ELEC
					10.74	10/29/25-11/26/25-ELEC
				100-0304-562.22-03	13.40	10/29/25-11/26/25-ELEC
				100-0305-562.22-03	25.68	10/29/25-11/26/25-ELEC
				100-0305-562.22-06	4.18	10/29/25-11/26/25-STORM
				100-0601-551.22-03	2,920.09	10/29/25-11/26/25-ELEC

AP Check Register

Check Date: 12/18/2025

<i>Vendor Name</i>	<i>Check Number</i>	<i>Check Date</i>	<i>Invoice Number</i>	<i>Account Number</i>	<i>Amount</i>	<i>Description</i>
MENASHA UTILITIES...	89295...	12/18/2025...	MENASHA UTIL....	100-0601-551.22-05	540.60	10/29/25-11/26/25-WAT/SEW
				100-0601-551.22-06	173.47	10/29/25-11/26/25-STORM
				100-0703-553.22-03	1,634.76	10/29/25-11/26/25-ELEC
				100-0703-553.22-05	1,419.42	10/29/25-11/26/25-WAT/SEW
				100-0703-553.22-06	1,664.71	10/29/25-11/26/25-STORM
				100-0704-552.22-03	255.49	10/29/25-11/26/25-ELEC
				100-0704-552.22-05	1,804.40	10/29/25-11/26/25-WAT/SEW
				100-0801-521.22-03	1,090.70	10/29/25-11/26/25-ELEC
				100-0801-521.22-05	409.23	10/29/25-11/26/25-WAT/SEW
				100-0801-521.22-06	107.28	10/29/25-11/26/25-STORM
				100-0920-531.22-03	365.30	10/29/25-11/26/25-ELEC
				100-0920-531.22-05	131.88	10/29/25-11/26/25-WAT/SEW
				100-1001-514.22-03	91.62	10/29/25-11/26/25-ELEC
				100-1008-541.22-03	407.44	10/29/25-11/26/25 - ELEC
				100-1008-541.22-05	16.68	10/29/25-11/26/25-WAT/SEW
				100-1012-541.22-03	410.76	10/29/25-11/26/25-ELEC
				100-1013-541.22-03	71.31	10/29/25-11/26/25-ELEC
				100-1013-541.22-06	73.15	10/29/25-11/26/25-STORM
				100-1019-552.22-03	22.66	10/29/25-11/26/25-ELEC
				207-0707-552.22-03	59.45	10/29/25-11/26/25-ELEC
				207-0707-552.22-05	228.57	10/29/25-11/26/25-WAT/SEW
				207-0707-552.22-06	42.85	10/29/25-11/26/25-STORM
				501-0304-562.22-03	158.78	10/29/25-11/26/25-ELEC
				501-0304-562.22-05	50.04	10/29/25-11/26/25-WAT/SEW
				501-0304-562.22-06	256.03	10/29/25-11/26/25-STORM
					233.21	09/29/25-10/29/25 STORM
				601-1020-543.22-03	266.72	10/29/25-11/26/25-ELEC
				731-1022-541.22-03	1,936.19	10/29/25-11/26/25-ELEC
				731-1022-541.22-05	1,261.41	10/29/25-11/26/25-WAT/SEW
				731-1022-541.22-06	1,629.16	10/29/25-11/26/25-STORM
			Total for check: 89295		20,948.72	

AP Check Register
Check Date: 12/18/2025

Date: 12/30/2025

<i>Vendor Name</i>	<i>Check Number</i>	<i>Check Date</i>	<i>Invoice Number</i>	<i>Account Number</i>	<i>Amount</i>	<i>Description</i>
ANNETTE NET	89296	12/18/2025	RENTAL DEP REFD	100-0000-201.11-00	100.00	RENTAL SECURITY DEPOSIT REFUND
			Total for check: 89296		100.00	
NEW HYDRAULICS	89297	12/18/2025	621222	731-1022-541.38-03	152.90	PLOW LIGHT HARNESS
			Total for check: 89297		152.90	
PACKER CITY INTL TRUCKS INC	89298	12/18/2025	X103158769:03	731-1022-541.38-03	148.36	LED LIGHT
		12/18/2025	X103159638:01	731-1022-541.38-03	529.69	AIR FILTERS
		12/18/2025	X103159638:02	731-1022-541.38-03	41.37	AIR FILTER/NUT
			Total for check: 89298		719.42	
PERSONNEL EVALUATION INC	89299	12/18/2025	56520	100-0801-521.21-06	125.00	PEP TEST BILLING NOVEMBER 2025
			Total for check: 89299		125.00	
QUENCH USA INC	89300	12/18/2025	INV09910314	100-0801-521.80-05	179.00	WATER FLAVORING
			Total for check: 89300		179.00	
RANGE SYSTEMS	89301	12/18/2025	34812	100-0801-521.30-15	1,971.91	DURA-BLOC RANGE BLOCKS
			Total for check: 89301		1,971.91	
KATHY RATHSACK	89302	12/18/2025	REIMBURSEMENT	100-0920-531.30-18	23.52	COFFEE MUG -REIMBURSEMENT
					14.99	CHRISTMAS GREENS -REIMBURSEMENT
					22.13	SCHROEDERS FOREVERGREENS 12/1/25-REIMBURSEME
			Total for check: 89302		60.64	
ELLE RAY	89303	12/18/2025	REFUND	100-0000-441.25-00	12.00	HANDMADE HOLIDAY -OVERPAYMENT REFUND
			Total for check: 89303		12.00	

AP Check Register

Check Date: 12/18/2025

Date: 12/30/2025

Vendor Name	Check Number	Check Date	Invoice Number	Account Number	Amount	Description
REDI-WELDING CO	89304	12/18/2025	15573	731-1022-541.38-03	80.00	METAL FABRICATION PARTS
	Total for check: 89304					80.00
REVIZE LLC	89305	12/18/2025	20226	743-0403-513.24-04	3,300.00	WEBSITE ANNUAL SUBSCRIPT.
	Total for check: 89305					3,300.00
YVONNE ROBBERS	89306	12/18/2025	REFUND	100-0000-441.25-00	58.00	PICKLEBALL CLASSES (2) REFUND
	Total for check: 89306					58.00
DIANE SCHABACH	89307	12/18/2025	761750	207-0707-552.21-06	4,611.89	PROFIT ON GAS SALES
		12/18/2025	812402	207-0707-552.30-18	677.93	MARINA SUPPLIES
	Total for check: 89307					5,289.82
SCHINDLER ELEVATOR CORP	89308	12/18/2025	4607313621	100-0601-551.24-03	776.88	ELEVATOR INSPECTION 12/1/25-11/30/26
	Total for check: 89308					776.88
SERVICE MOTOR COMPANY	89309	12/18/2025	P19118	731-1022-541.38-03	36.46	SWITCHES
	Total for check: 89309					36.46
SERVICEMASTER BUILDING MAINTENANCE	89310	12/18/2025	48110	100-0920-531.20-01	480.00	JANITORIAL SERVICE SENIOR CENTER
		12/18/2025	48115	731-1022-541.20-01	2,730.00	JANITORIAL SERVICE PUBLIC WORKS FACILITY
		12/18/2025	48125	100-0801-521.20-01	2,016.00	JANITORIAL SERVICE -POLICE
	Total for check: 89310					5,226.00
STANTEC CONSULTING SERVICES INC	89311	12/18/2025	2497918	256-0304-562.21-06	18,408.98	PROFESSIONAL SERVICES BROWNFIELD ASSES. GRAN
	Total for check: 89311					18,408.98

AP Check Register

Check Date: 12/18/2025

Vendor Name	Check Number	Check Date	Invoice Number	Account Number	Amount	Description
STRAND ASSOCIATES INC	89312	12/18/2025	0231732	470-0703-553.80-05	1,634.46	PROFESSIONAL SERVICES PR-2025-011 JEFF PRK BOAT
	Total for check: 89312					1,634.46
WASTEQUIP LLC	89313	12/18/2025	3977384	731-1022-541.38-03	663.02	PARTS
	Total for check: 89313					663.02
WE ENERGIES	89314	12/18/2025	5733844073	100-0701-533.22-03	17.27	11/5/25-12/8/25-ELECTRIC NORTH ST
		12/18/2025	5734985069	100-0701-533.22-03	17.27	11/5/25-12/8/25-ELECTRIC NORTH ST
	Total for check: 89314					34.54
TERMINIX WIL-KIL	89315	12/18/2025	89247292	731-1022-541.20-07	98.03	PEST CONTROL MAINTENANCE PUBLIC WORKS FACILITY
		12/18/2025	89247690	100-0703-553.20-07	40.45	PEST CONTROL MAINTENANCE KOSLO PARK
		12/18/2025	89248664	100-0501-522.24-03	78.00	PEST CONTROL MAINTENANCE N-M FIRE STATION #36
	Total for check: 89315					216.48
WINNEBAGO COUNTY TREASURER	89316	12/18/2025	32527	100-0805-521.25-01	411.68	INMATE STAYS-OCTOBER
	Total for check: 89316					411.68
WISCONSIN CHIEFS OF POLICE ASSN INC	89317	12/18/2025	14594	100-0801-521.32-01	100.00	MEMBERSHIP RENEWAL
	Total for check: 89317					100.00
WISCONSIN PARK & RECREATION ASSN	89318	12/18/2025	10269	100-0703-553.32-01	150.00	WPRA MEMBERSHIP RENEWAL -THAD
		12/18/2025	10333	100-0704-552.32-01	150.00	MEMBERSHIP RENEWAL -CHLOE
		12/18/2025	10338	100-0703-553.32-01	150.00	WPRA MEMBERSHIP RENEWAL -MEGAN
		12/18/2025	10971	100-0703-553.34-02	300.00	2026 ANNUAL CONFERENCE REGISTRATION-THAD
		12/18/2025	10973	100-0702-552.34-02	415.00	2026 ANNUAL CONFERENCE REGISTRATION-LORI
	Total for check: 89318					1,165.00

AP Check Register
Check Date: 12/18/2025

Date: 12/30/2025

<i>Vendor Name</i>	<i>Check Number</i>	<i>Check Date</i>	<i>Invoice Number</i>	<i>Account Number</i>	<i>Amount</i>	<i>Description</i>
TIFFANY WITT	89319	12/18/2025	RENTAL DEP REFD	100-0000-201.11-00	100.00	RENTAL SECURITY DEPOSIT REFUND
			Total for check: 89319		100.00	
1ST AYD CORPORATION	89320	12/18/2025	PSI834429	731-1022-541.30-18	232.90	SHOP SUPPLIES
			Total for check: 89320		232.90	
					87,733.82	

AP Check Register

Check Date: 12/19/2025

Vendor Name	Check Number	Check Date	Invoice Number	Account Number	Amount	Description			
AMAZON CAPITAL SERVICES	89322	12/19/2025	117G-H173-1PCX	100-0601-551.30-14	12.74	LIBRARY MATERIALS			
			11PN-K6TK-31VX	100-0601-551.30-16	24.98	LIBRARY PROMOTIONAL			
			14TX-PD67-7JGR	100-0601-551.30-14	64.99	LIBRARY MATERIALS			
			1746-RQ3K-DHHW	100-0601-551.30-12	59.98	COMPUTER SUPPLIES			
			17LT-6JD1-K3NC	100-0601-551.30-16	269.24	LIBRARY PROMOTIONAL			
			17MY-FYCQ-C7WG	100-0601-551.30-10	62.99	LIBRARY SUPPLIES			
			17VR-1RKQ-KHRW	100-0601-551.30-16	63.63	LIBRARY PROMOTIONAL			
			17VR-1RKQ-KN7W	100-0601-551.30-14	79.87	LIBRARY MATERIALS			
			1CNW-TTPT-79P4	100-0601-551.30-14	67.20	LIBRARY MATERIALS			
			1DF7-KQJH-GDXW	100-0601-551.30-16	19.98	LIBRARY PROMOTIONAL			
			1GLW-HF4J-MRYX	100-0601-551.30-18	7.29	DEPARTMENT SUPPLIES			
			1JQ4-QWWL-G9YH	100-0601-551.30-14	14.99	LIBRARY MATERIALS			
			1KFF-MFC3-GTYX	100-0601-551.30-16	94.71	LIBRARY PROMOTIONAL			
			1KLH-TWMQ-KKGC	100-0601-551.30-14	14.18	LIBRARY MATERIALS			
			1KXJ-FGJ9-JN1J	100-0601-551.30-10	6.64	LIBRARY SUPPLIES			
			1N7C-1QVQ-KGJF	100-0601-551.30-14	56.98	LIBRARY MATERIALS			
			1QQ7-W91G-KNPC	100-0601-551.30-14	59.99	LIBRARY MATERIALS			
			1RYD-V6M4-KHLD	100-0601-551.30-10	33.99	LIBRARY SUPPLIES			
			1TQD-QHRN-HHTL	100-0601-551.30-10	58.62	LIBRARY SUPPLIES			
			1TR7-LP77-97C6	100-0601-551.30-14	31.25	LIBRARY MATERIALS			
			1W17-KFFL-HYHR	100-0601-551.30-16	10.98	LIBRARY PROMOTIONAL			
			1WDY-N7LN-V6HQ	100-0601-551.30-10	52.69	LIBRARY SUPPLIES			
			1WDY-N7LN-V9TV	100-0601-551.30-14	9.99	LIBRARY MATERIALS			
			1XP1-R4TJ-RVPC	100-0601-551.30-16	52.99	LIBRARY PROMOTIONAL			
			1YFF-YJDD-VJ6F	100-0601-551.30-14	46.48	LIBRARY MATERIALS			
			Total for check: 89322					1,277.37	
			WENDY ANTOINE	89323	12/19/2025	REIMBURSMENT	100-0601-551.30-14	24.73	LIB MATERIALS REIMBURSMNT
						Total for check: 89323			
CARING TRANSITION OF EAST CENTRAL	89324	12/19/2025	CONTRACT	100-0601-551.20-05	125.00	CONTRACT 1/15/26			
			Total for check: 89324					125.00	

AP Check Register

Check Date: 12/19/2025

Vendor Name	Check Number	Check Date	Invoice Number	Account Number	Amount	Description
CENGAGE LEARNING INC/GALE	89325	12/19/2025	999101692807	100-0601-551.30-14	276.71	LIBRARY MATERIALS
		12/19/2025	999101704182	100-0601-551.30-14	30.39	LIBRARY MATERIALS
		12/19/2025	999101736130	100-0601-551.30-14	49.48	LIBRARY MATERIALS
	Total for check: 89325					356.58
CENTER POINT LARGE PRINT	89326	12/19/2025	2206080	100-0601-551.30-14	303.24	LIBRARY MATERIALS
		12/19/2025	CONTRACT	100-0601-551.20-05	200.00	CONTRACT
	Total for check: 89326					503.24
CRIMSON MULTIMEDIA	89327	12/19/2025	025645	100-0601-551.30-14	136.12	LIBRARY MATERIALS
		12/19/2025	025646	100-0601-551.30-14	40.00	LIBRARY MATERIALS
		12/19/2025	025647	100-0601-551.30-14	40.00	LIBRARY MATERIALS
		12/19/2025	05648	100-0601-551.30-14	141.71	LIBRARY MATERIALS
	Total for check: 89327					357.83
DANZARTE LLC	89328	12/19/2025	CONTRACT	100-0601-551.20-05	250.00	CONTRACT
	Total for check: 89328					250.00
EBSCO INDUSTRIES INC	89329	12/19/2025	1811060	100-0601-551.30-14	51.50	LIBRARY MATERIALS
	Total for check: 89329					51.50
GORDON FLESCH CO LEASING	89330	12/19/2025	I01074827	100-0601-551.24-01	329.68	OFFICE EQUIPMENT
	Total for check: 89330					329.68
STEPHANIE HALL	89331	12/19/2025	CONTRACT	100-0601-551.20-05	150.00	CONTRACT 1/26/26
	Total for check: 89331					150.00
INGRAM LIBRARY SERVICES	89333	12/19/2025	91680852	100-0601-551.30-14	61.82	LIBRARY MATERIALS
		12/19/2025	91680853	100-0601-551.30-14	437.70	LIBRARY MATERIALS
		12/19/2025	91693154	100-0601-551.30-14	263.98	LIBRARY MATERIALS

AP Check Register

Check Date: 12/19/2025

Vendor Name	Check Number	Check Date	Invoice Number	Account Number	Amount	Description	
INGRAM LIBRARY SERVICES...	89333...	12/19/2025	91764369	100-0601-551.30-14	158.92	LIBRARY MATERIALS	
		12/19/2025	91776570	100-0601-551.30-14	580.85	LIBRARY MATERIALS	
		12/19/2025	91821368	100-0601-551.30-14	146.19	LIBRARY MATERIALS	
						198.60	LIBRARY MATERIALS
			12/19/2025	91833481	100-0601-551.30-14	167.60	LIBRARY MATERIALS
			12/19/2025	91844738	100-0601-551.30-14	373.82	LIBRARY MATERIALS
			12/19/2025	91844739	100-0601-551.30-14	198.92	LIBRARY MATERIALS
			12/19/2025	91844740	100-0601-551.30-14	20.92	LIBRARY MATERIALS
			12/19/2025	91866874	100-0601-551.30-14	101.37	LIBRARY MATERIALS
			12/19/2025	91866875	100-0601-551.30-14	222.33	LIBRARY MATERIALS
			12/19/2025	91949731	100-0601-551.30-14	209.96	LIBRARY MATERIALS
			12/19/2025	91976909	100-0601-551.30-14	146.55	LIBRARY MATERIALS
			12/19/2025	91976910	100-0601-551.30-14	335.12	LIBRARY MATERIALS
			12/19/2025	92004965	100-0601-551.30-14	218.35	LIBRARY MATERIALS
			12/19/2025	92004966	100-0601-551.30-14	289.00	LIBRARY MATERIALS
			12/19/2025	92062275	100-0601-551.30-14	423.87	LIBRARY MATERIALS
			12/19/2025	92149126	100-0601-551.30-14	525.02	LIBRARY MATERIALS
			12/19/2025	92149127	100-0601-551.30-14	267.42	LIBRARY MATERIALS
			12/19/2025	92183958	100-0601-551.30-14	29.86	LIBRARY MATERIALS
			12/19/2025	92183959	100-0601-551.30-14	169.23	LIBRARY MATERIALS
			12/19/2025	92194452	100-0601-551.30-14	14.40	LIBRARY MATERIALS
			12/19/2025	92291098	100-0601-551.30-14	327.65	LIBRARY MATERIALS
			12/19/2025	92308406	100-0601-551.30-14	89.22	LIBRARY MATERIALS
		12/19/2025	92308407	100-0601-551.30-14	767.73	LIBRARY MATERIALS	
		12/19/2025	92308408	100-0601-551.30-14	498.89	LIBRARY MATERIALS	
			Total for check: 89333		7,245.29		
NADINE JANIK	89334	12/19/2025	CONTRACT	100-0601-551.20-05	200.00	CONTRACT 1/19/26	
						200.00	
KAEL KING	89335	12/19/2025	CONTRACT	100-0601-551.20-05	75.00	CONTRACT 1/10/26	
						75.00	

AP Check Register

Check Date: 12/19/2025

Vendor Name	Check Number	Check Date	Invoice Number	Account Number	Amount	Description
KWIK TRIP INC STORE #297	89336	12/19/2025	MR Refund	100-0000-123.00-00	100.00	KWIK TRIP INC STORE #297 MR Refund Voucher
	Total for check: 89336				100.00	
METRO SALES INC	89337	12/19/2025	INV2948700	100-0601-551.24-04	568.29	PRINTER/COPIER USAGE
		12/19/2025	INV2955941	100-0601-551.24-04	81.69	PRINTER/COPIER USAGE
	Total for check: 89337				649.98	
MIDWEST TAPE	89338	12/19/2025	508045929	100-0601-551.30-14	80.22	LIBRARY MATERIALS
		12/19/2025	508067652	100-0601-551.30-14	441.58	LIBRARY MATERIALS
		12/19/2025	508067654	100-0601-551.30-14	70.48	LIBRARY MATERIALS
	Total for check: 89338				592.28	
SHELLY PLATTEN	89339	12/19/2025	CONTRACT	100-0601-551.20-05	200.00	CONTRACT 1/10/26
	Total for check: 89339				200.00	
SERVICEMASTER BUILDING MAINTENANCE	89340	12/19/2025	48126	100-0601-551.20-01	2,760.00	JANITORIAL SERVICE
	Total for check: 89340				2,760.00	
JOSHUA SPOTTS	89341	12/19/2025	CONTRACT	100-0601-551.20-05	50.00	CONTRACT 1/20/26
	Total for check: 89341				50.00	
WINNEFOX LIBRARY SYSTEM	89342	12/19/2025	WLS4199	100-0601-551.30-14	12.00	LIBRARY MATERIALS
	Total for check: 89342				12.00	
ROB ZIMMER	89343	12/19/2025	CONTRACT	100-0601-551.20-05	150.00	CONTRACT 1/12/26
	Total for check: 89343				150.00	
					15,460.48	

AP Check Register

Check Date: 12/23/2025

Date: 12/30/2025

Vendor Name	Check Number	Check Date	Invoice Number	Account Number	Amount	Description
AMAZON CAPITAL SERVICES	89344	12/23/2025	1PNH-Y99V-97YP	100-0401-513.30-10	6.62	OSSICE SUPPLIES
				100-0401-513.30-19	155.97	OFFICE FURNISHINGS
				Total for check: 89344		162.59
CITY OF APPLETON	89345	12/23/2025	18922	100-0302-542.25-01	20,317.00	DECEMBER-TRANSIT SERVICES
				Total for check: 89345		20,317.00
BENEFIT COORDINATORS CORP	89346	12/23/2025	B0L53Z	734-0416-513.21-06	2,589.26	MONTHLY FAHP FEE-DEC
				Total for check: 89346		2,589.26
CDW GOVERNMENT INC	89347	12/23/2025	AH1DY1X	470-0403-513.80-01	1,646.78	POWER SUPPLY & CABLES -CORE SWITCH/ IT-2025-001
			AH1E32W	470-0403-513.80-01	22,638.56	CORE SWITCH REPLACEMENT IT-2025-001
			AH1QR6F	470-0403-513.80-01	10,385.32	HPE SERVICE AGREEMENT -CORE SWITCH/ IT-2025-001
			AH1Z99D	470-0403-513.80-01	1,665.20	10GBASE + TRANSCEIVER (8)-CORE SWITCH/ IT-2025-001
			Total for check: 89347		36,335.86	
CENTER POINT LARGE PRINT	89348	12/23/2025	2206080-1	100-0601-551.30-14	303.24	LIBRARY MATERIALS
				Total for check: 89348		303.24
CONQUER BOOKS	89349	12/23/2025	CONTRACT	100-0601-551.20-05	200.00	CONTRACT
				Total for check: 89349		200.00
EAST CENTRAL WISCONSIN	89350	12/23/2025	0001831-IN	100-0304-562.21-02	2,039.37	COMPREHENSIVE PLANNING Q3 2025 SERVICES
				Total for check: 89350		2,039.37
EHLERS & ASSOCIATES INC	89351	12/23/2025	104098	100-0000-201.03-00	1,925.00	PROVINCE TERRACE-TID 15
				Total for check: 89351		1,925.00
ELAN FINANCIAL SERVICES	89358	12/23/2025	0138	100-0501-522.24-03	115.85	LIGHT BULBS FIRE

AP Check Register

Check Date: 12/23/2025

<i>Vendor Name</i>	<i>Check Number</i>	<i>Check Date</i>	<i>Invoice Number</i>	<i>Account Number</i>	<i>Amount</i>	<i>Description</i>
ELAN FINANCIAL SERVICES...	89358...	12/23/2025	0164	826-0702-552.30-18	86.16	CONCESSIONS PARKS & REC
		12/23/2025	0306	100-0702-552.32-01	70.00	SCHEDULING PARKS & REC
		12/23/2025	0506	824-0814-521.30-18	400.00	MENASHA COMM OUTREACH POLICE
		12/23/2025	0617	743-0403-513.30-15	19.72	USB IT
		12/23/2025	0621	100-0601-551.30-16	81.27	INT'L GAME DAY PROG LIBRARY
		12/23/2025	0746	100-1019-552.30-18	2,075.00	CAMERA BRIDGES
		12/23/2025	0790	100-0601-551.30-16	38.75	FACEBOOK ADS LIBRARY
		12/23/2025	0903	100-0601-551.30-11	16.85	INTER LIBRARY LOAN LIBRARY
		12/23/2025	1029	100-0904-531.32-01	75.00	RS LICENSE RENEWAL ENVIROMENTAL HEALTH
		12/23/2025	1098	100-0601-551.30-14	31.49	MONTHLY SUBSCRIPTION LIBRARY
		12/23/2025	1430	100-0601-551.32-01	39.00	DONOR SOFTWARE LIBRARY
		12/23/2025	1655	601-1020-543.30-18	(50.00)	DRIVE PART SEWER
		12/23/2025	1754	100-0702-552.30-18	18.41	GATHER AROUND PARKS & REC
		12/23/2025	1789	100-0801-521.34-03	267.00	TRANING LODGING POLICE
		12/23/2025	1797	100-0801-521.34-03	267.00	TRANING LODGING POLICE
		12/23/2025	1809	100-0801-521.34-02	850.00	TRAINING REGISTRATION POLICE
		12/23/2025	1931	100-0801-521.34-02	445.00	TRAINING REGISTRATION POLICE
		12/23/2025	1957	100-0601-551.30-16	117.03	INT'L GAME DAY PROG LIBRARY
		12/23/2025	2176	100-0801-521.30-11	14.66	POSTAGE POLICE
		12/23/2025	2348	100-0601-551.30-14	514.89	INT'L GAME DAY PROG LIBRARY
		12/23/2025	2373	100-0601-551.30-16	51.58	SURVEY INCENTIVES LIBRARY
		12/23/2025	2488	100-0601-551.30-16	21.00	MONTHLY SUBSCRIPTION LIBRARY
		12/23/2025	2509	100-0301-523.30-18	0.56	SERVICE FEE COMMUNITY DEVELOPMENT
		12/23/2025	2595	100-0903-531.34-02	125.00	SCHOOL NURSE SESSION HEALTH DEPARTMENT
		12/23/2025	2773	100-0920-531.30-18	32.05	FRESH GREENS SENIOR CENTER
		12/23/2025	3056	100-0801-521.30-11	16.85	POSTAGE POLICE
		12/23/2025	3283	601-1020-543.30-18	2,128.21	9TH STREET LIFT DRIVE SEWER
		12/23/2025	3463	100-0801-521.30-11	10.89	POSTAGE POLICE
		12/23/2025	3539	100-0301-523.30-18	25.00	HVAC EXAM LORI FULCER COMMUNITY DEVELOPMENT
		12/23/2025	3749	824-0814-521.30-18	73.84	MENASHA COMM OUTREACH POLICE
		12/23/2025	3794	100-0601-551.30-14	13.70	ROKUS LIBRARY
		12/23/2025	3849	100-0301-523.30-18	85.00	REGISTRATION FEES COMMUNITY DEVELOPMENT
		12/23/2025	4613	100-0601-551.30-16	11.00	MONTHLY SUBSCRIPTION LIBRARY
	12/23/2025	4766	100-0920-531.30-18	45.00	GARLAND TREE CRAFT SENIOR CENTER	
	12/23/2025	5093	100-0601-551.30-16	6.00	ADULT PROGRAMMING LIBRARY	

AP Check Register
Check Date: 12/23/2025

Date: 12/30/2025

Vendor Name	Check Number	Check Date	Invoice Number	Account Number	Amount	Description
ELAN FINANCIAL SERVICES...	89358...	12/23/2025...	5093...	100-0601-551.30-16...	8.00	ADULT PROGRAMMING LIBRARY
		12/23/2025	5207	743-0403-513.30-15	16.38	ADAPTER/CONNECTOR IT
		12/23/2025	5217	100-0601-551.30-14	31.50	MONTHLY SUBSCRIPTION LIBRARY
		12/23/2025	5224	100-0601-551.30-16	50.00	SURVEY INCENTIVES LIBRARY
		12/23/2025	5247	731-1022-541.38-03	15.86	ROLLER PARTS PUBLIC WORKS
		12/23/2025	5361	100-1008-541.30-15	169.00	TOOLS SIGN
		12/23/2025	5381	100-0904-531.32-01	1.69	E-SERVICE FEE ENVIROMENTAL HEALTH
		12/23/2025	5471	100-0802-521.33-03	28.07	NNO WINNER - PIZZA PARTY POLICE
		12/23/2025	5675	100-0804-521.30-15	235.66	BATTERIES POLICE
		12/23/2025	5862	100-0903-531.21-12	67.15	TRANSLATION (SWAHILI) HEALTH DEPARTMENT
		12/23/2025	5881	100-0601-551.30-14	41.99	DIGITAL RESOURCE LIBRARY
		12/23/2025	5911	100-0601-551.30-16	1.04	VETS DAY PROGRAM LIBRARY
		12/23/2025	6005	100-0801-521.34-02	1,040.00	TRAINING REGISTRATION POLICE
		12/23/2025	6094	100-0601-551.30-16	50.00	SURVEY INCENTIVES LIBRARY
		12/23/2025	6113	100-0601-551.30-14	13.70	ROKUS LIBRARY
		12/23/2025	6126	731-1022-541.38-03	79.50	SWITCH PARTS PUBLIC WORKS
		12/23/2025	6204	824-0807-521.30-15	15.83	K-9 SERVICES POLICE
		12/23/2025	6296	100-0601-551.30-14	65.00	POST CRESCENT SUBSCRIPTONLIBRARY
		12/23/2025	6460	100-0601-551.20-05	161.96	SOAR MEETING LIBRARY
		12/23/2025	6528	100-0702-552.30-18	51.37	HOL HAYRIDE/GATHER ROUND PARKS & REC
				100-0920-531.30-18	27.67	SCAMS/CRAFTS PRESENTATIONPARKS & REC
		12/23/2025	6536	100-0000-201.14-00	48.84	ARK BUS TRIP SENIOR CENTER
		12/23/2025	6754	100-0601-551.30-16	51.74	SURVEY INCENTIVES LIBRARY
		12/23/2025	6804	100-0601-551.30-16	6.99	MOVIE DIGITAL COPY LIBRARY
		12/23/2025	6809	100-0703-553.30-18	64.00	PROPANE SUPPLIES PUBLIC WORKS
		12/23/2025	6959	100-0702-552.30-18	95.16	HOLIDAY HAYRIDE PARKS & REC
				100-0920-531.30-18	9.88	CHRISTMAS PARTY SENIOR CENTER
				827-0920-531.30-18	76.22	SNACK SALES SENIOR CENTER
		12/23/2025	6985	100-0601-551.30-14	26.24	ROKUS LIBRARY
		12/23/2025	7038	100-0801-521.34-04	192.92	TRAINING/AWARD PINS POLICE
		12/23/2025	7094	100-0801-521.34-02	175.00	TRANING REGISTRATION POLICE
		12/23/2025	7095	100-0601-551.30-16	29.99	STOCK SUBSCRIPTION LIBRARY
		12/23/2025	7138	100-0301-523.30-18	31.40	RETURN ADDRESS STAMP COMMUNITY DEVELOPMENT
		12/23/2025	7346	100-0801-521.29-04	78.30	VEHICLE REPAIR POLICE
		12/23/2025	7355	100-0801-521.34-04	61.32	TRANING/MISC SUPPLIES POLICE

AP Check Register

Check Date: 12/23/2025

Vendor Name	Check Number	Check Date	Invoice Number	Account Number	Amount	Description	
ELAN FINANCIAL SERVICES...	89358...	12/23/2025	7461	743-0403-513.30-15	6.37	CELL PHONE CASE IT	
		12/23/2025	7473	100-0801-521.32-01	100.00	DUES/MEMBERSHIPS POLICE	
		12/23/2025	7668	100-0920-531.30-18	92.19	CRAFT SUPPLIES SENIOR CENTER	
		12/23/2025	7669	100-0601-551.30-16	42.90	ADULT PROGRAMMING LIBRARY	
		12/23/2025	7858	731-1022-541.24-03	128.23	SENSOR PUBLIC WORKS	
		12/23/2025	7870	100-0920-531.30-18	33.89	FRESH GREENS SENIOR CENTER	
		12/23/2025	8033	100-0702-552.29-03	5.71	GATHER/PLAY AD PARKS & REC	
				100-0702-552.30-18	101.95	PICKLEBALLS PARKS & REC	
		12/23/2025	8053	100-1019-552.30-18	84.96	POWER SUPPLY BRIDGES	
		12/23/2025	8058	100-0903-531.21-12	35.55	TRANSLATION (SWAHILI) HEALTH DEPARTMENT	
		12/23/2025	8064	100-0601-551.30-14	13.70	ROKUS LIBRARY	
		12/23/2025	8098	100-0601-551.30-16	40.00	SURVEY INCENTIVES LIBRARY	
		12/23/2025	8219	100-0601-551.30-16	3.15	LASER CUTTER PATTERN LIBRARY	
		12/23/2025	8273	100-0702-552.29-03	425.00	VALLEY GUIDE ADS PARKS & REC	
		12/23/2025	8457	100-0601-551.30-16	51.50	SURVEY INCENTIVES LIBRARY	
		12/23/2025	8542	100-0601-551.30-16	98.12	INT'L GAME DAY PROG LIBRARY	
		12/23/2025	8653	100-0101-511.33-02	30.00	URBAN ALLIANCE MEETING MAYOR	
		12/23/2025	8668	100-0801-521.30-11	10.94	POSTAGE POLICE	
		12/23/2025	8723	100-0601-551.30-14	24.99	ROKUS LIBRARY	
		12/23/2025	8884	100-0920-531.32-01	190.95	ACTIVITY GUIDE SENIOR CENTER	
		12/23/2025	8963	731-1022-541.38-03	39.89	BELT PARTS PUBLIC WORKS	
		12/23/2025	9065	100-0601-551.30-14	13.70	ROKUS LIBRARY	
		12/23/2025	9114	100-0601-551.30-11	8.50	INTER LIBRARY LOAN LIBRARY	
		12/23/2025	9220	100-0601-551.30-14	257.18	MONTHLY SUBSCRIPTION LIBRARY	
		12/23/2025	9425	100-0601-551.30-16	50.00	SURVEY INCENTIVES LIBRARY	
		12/23/2025	9567	100-1003-541.30-15	169.00	TOOLS STREET	
		12/23/2025	9597	100-0811-521.34-02	50.00	BIANEW MEMBERSHIP DUES LFCOMMUNITY DEVELOPME	
		12/23/2025	9766	100-0801-521.29-01	90.22	PRINTING POLICE	
		12/23/2025	9962	100-1019-552.30-18	284.00	CONVERTOR SWITCH BRIDGES	
	Total for check: 89358					13,740.72	

AP Check Register
Check Date: 12/23/2025

Date: 12/30/2025

<i>Vendor Name</i>	<i>Check Number</i>	<i>Check Date</i>	<i>Invoice Number</i>	<i>Account Number</i>	<i>Amount</i>	<i>Description</i>
FAHRNER ASPHALT SEALERS LLC	89359	12/23/2025	2025-04	100-1003-541.20-10	31,734.00	ASPHALTIC CONCRETE PVMT CRACK SEALING-STREETS
			Total for check: 89359		31,734.00	
FOX COMMUNITIES CREDIT UNION	89360	12/23/2025	20013700	100-0000-212.00-00	1,099.69	OVERPAYMENT TAXES VANLANEN, RYAN
			Total for check: 89360		1,099.69	
GREAT BIG GRAPHICS LLC	89361	12/23/2025	11565	100-1002-541.30-10	62.25	BUSINESS CARDS
				625-1002-541.30-10	20.75	BUSINESS CARDS
			Total for check: 89361		83.00	
DAVID LAMBIE	89362	12/23/2025	60107200	100-0000-212.00-00	6.86	OVERPAYMENT TAXES
			Total for check: 89362		6.86	
MCMAHON	89363	12/23/2025	941276	625-1010-541.24-05	13,773.92	VEGETATIVE MAINTENANCE POND
			Total for check: 89363		13,773.92	
MENASHA TREASURER	89364	12/23/2025	START UP CASH	100-0000-441.25-00	30.00	START UP CASH-ICE RINK
			Total for check: 89364		30.00	
MENASHA UTILITIES	89365	12/23/2025	5200	601-0401-513.25-01	23,420.42	NOV-SEWER CHARGES
				625-0401-513.25-01	1,948.74	NOV-STORMWATER CHARGES
		12/23/2025	MENASHA UTIL.	100-1008-541.22-03	86.12	09/29/25-10/29/25 ELEC
				100-1012-541.22-03	10,957.24	NOVEMBER STREET LIGHTING
			Total for check: 89365		36,412.52	
METRO SALES INC	89366	12/23/2025	INV2937510	743-0403-513.29-01	1,658.50	COPIER/PRINTER USAGE 10/17/25-11/16/25
		12/23/2025	INV2939889	100-0801-521.30-18	133.86	COPIER STAPLES-PD
			Total for check: 89366		1,792.36	

AP Check Register

Check Date: 12/23/2025

Vendor Name	Check Number	Check Date	Invoice Number	Account Number	Amount	Description
NEENAH-MENASHA SEWERAGE COMMISSION	89367	12/23/2025	2025-214	601-1020-543.21-02	878.38	CLEAN & TV AT GARFIELD & MATTHEWSON
Total for check: 89367					878.38	
NORTHEAST ASPHALT INC	89368	12/23/2025	PAYMENT #4	470-0000-201.04-00 470-0703-553.82-02	(2,955.75) 377,824.03	CONTRACT #2025-03 JEFF PARK BOAT LAUNCH CONTRACT #2025-03 JEFF PARK BOAT LAUNCH
Total for check: 89368					374,868.28	
REGISTRATION FEE TRUST	89369	12/23/2025	LICENSE	100-0801-521.29-04	1.00	LICENSE PLATE ISSUANCE
Total for check: 89369					1.00	
RUEKERT & MIELKE INC	89370	12/23/2025	160702	601-1020-543.21-02	332.50	PROFESSIONAL SERVICES -OCTOBER SEWER BILLINGS
Total for check: 89370					332.50	
SECURIAN FINANCIAL GROUP INC	89371	12/23/2025	002832L	100-0000-204.07-00	3,566.84	JAN 2026-LIFE INSURANCE
Total for check: 89371					3,566.84	
COUNTY OF SHEBOYGAN	89372	12/23/2025	467872	100-1003-541.30-18	1,689.37	COLD MIX STREET SUPPLIES
Total for check: 89372					1,689.37	
SOMMERS CONSTRUCTION INC	89373	12/23/2025	PYMT #3 & FINAL	470-0000-201.04-00 470-1003-541.82-02 625-0000-194.00-00	5,000.00 29,710.21 5,307.75	STREET CONSTRUCTION CONTRACT #2025-02 STREET CONSTRUCTION CONTRACT #2025-02 STREET CONSTRUCTION CONTRACT #2025-02
Total for check: 89373					40,017.96	
SUPERIOR VISION INSURANCE PLAN	89374	12/23/2025	934997	100-0000-204.10-00	1,085.43	JANUARY-VISION INSURANCE
Total for check: 89374					1,085.43	
WPPI ENERGY	89375	12/23/2025	INV23827	310-0409-571.61-01	494.50 1,010.30	DEC STREET LIGHTING PROJ DEC LED STREETLIGHT PROJ

AP Check Register
Check Date: 12/23/2025

Date: 12/30/2025

<i>Vendor Name</i>	<i>Check Number</i>	<i>Check Date</i>	<i>Invoice Number</i>	<i>Account Number</i>	<i>Amount</i>	<i>Description</i>
WPPI ENERGY...	89375...	12/23/2025...	INV23827...	310-0409-571.61-01...	283.33	DEC LED STREETLIGHT PROJ
				731-1022-541.82-01	1,176.09	DEC SOLAR PV-PUBLIC WORKS
					769.99	DEC SOLAR PV-PUBLIC WORKS
			Total for check: 89375		3,734.21	
WVDL-MADISON	89376	12/23/2025	IV:25149:0094	100-0806-532.25-01	532.00	ANIMAL CREMATION/NECROPSY
			Total for check: 89376		532.00	
					589,251.36	

AP Check Register

Check Date: 12/31/2025

Vendor Name	Check Number	Check Date	Invoice Number	Account Number	Amount	Description
AMAZON CAPITAL SERVICES	89377	12/31/2025	13F4-QQNJ-9DKL	100-0203-512.30-10	23.99	LANYARDS
				100-0204-512.30-10	11.89	STICKY INDEX TABS
		12/31/2025	13XM-QK96-XWXG	100-0801-521.30-15	697.99	SMART TV
		12/31/2025	17LC-MP4C-CFCV	100-0801-521.19-03	72.72	MEN'S TACTICAL PANTS
		12/31/2025	1N9V-XCYC-T94T	100-0803-521.19-03	78.99	HEAVY DUTY UTILITY CART
		12/31/2025	1PVH-YR94-X1DL	100-0903-531.30-18	12.33	9V ALKALINE BATTERIES
				100-0909-531.30-18	33.48	PAPER TOWELS
		12/31/2025	1XKW-L93T-67MF	100-0801-521.30-12	64.59	WIRELESS HDMI TRANSMITTER& RECEIVER
Total for check: 89377					995.98	
APPLETON NAIL NURSE LLC	89378	12/31/2025	NAIL APPTS	100-0920-531.20-05	502.00	NAIL APPOINTMENTS-DEC
			Total for check: 89378			
ARING EQUIPMENT COMPANY INC	89379	12/31/2025	920376	731-1022-541.38-03	593.06	FARENHEIT CONTROL PANEL
			920573	731-1022-541.38-03	(593.06)	FARENHEIT CONTROL PANEL CREDIT
			E31321	731-1022-541.29-04	2,170.97	SOFTWARE UPDATE/INSTALL NEW DEF ARMATURE
			Total for check: 89379			
BERGSTROM FORD LINCOLN	89380	12/31/2025	114164	731-1022-541.38-04	1,400.11	MUFFLER ASSEMBLY, GASKET
			114365	731-1022-541.38-04	33.44	GASKET
			114514	731-1022-541.38-04	737.39	ALTERNATOR ASY, V-BELT, TENSIONER
			Total for check: 89380			
BOBCAT PLUS	89381	12/31/2025	IA22187	731-1022-541.38-03	36.63	SWITCH ROCK, OIL FILTER
			IA22242	731-1022-541.38-03	365.20	BOBCAT PARTS
		Total for check: 89381				
CDW GOVERNMENT INC	89382	12/31/2025	AH1SG4V	100-0801-521.29-07	5,148.80	NUANCE DRGN/USER MGMT -PD
			Total for check: 89382			

AP Check Register
Check Date: 12/31/2025

Date: 12/31/2025

<i>Vendor Name</i>	<i>Check Number</i>	<i>Check Date</i>	<i>Invoice Number</i>	<i>Account Number</i>	<i>Amount</i>	<i>Description</i>
CLEARPATH INVESTIGATIONS LLC	89383	12/31/2025	1002	100-0801-521.21-06	1,640.24	BACKGROUND CHECK -PD
			Total for check: 89383		1,640.24	
MICHELLE COGGINS	89384	12/31/2025	RENTAL DEP REFD	100-0000-201.11-00	100.00	RENTAL SECURITY DEPOSIT REFUND
			Total for check: 89384		100.00	
COTALITY CENTRALIZED REFUNDS	89385	12/31/2025	OVERPAID TAXES	100-0000-212.00-00	8,096.40	OVERPAYMENT TAXES 30051600, 50075300
			Total for check: 89385		8,096.40	
DIAMOND TOURS INC	89386	12/31/2025	2226597	100-0000-201.14-00	52,199.00	SAVANNAH JEKYLL ISLAND TRIP 3.7.26 - 3.14.25
			Total for check: 89386		52,199.00	
FACTORY MOTOR PARTS CO	89387	12/31/2025	18-2330935	731-1022-541.38-03	174.81	BATTERY PARTS
		12/31/2025	18-2331801	731-1022-541.38-03	12.80	CARTRIDGE LUBE FILTER (2)
		12/31/2025	18-Z34965	731-1022-541.38-03	317.62	BATTERY CORE
			Total for check: 89387		505.23	
BRADY GREGURICH	89388	12/31/2025	30021100	100-0000-212.00-00	260.17	OVERPAYMENT TAXES
			Total for check: 89388		260.17	
LISA HOWARD	89389	12/31/2025	70018700	100-0000-212.00-00	31.55	OVERPAYMENT TAXES
			Total for check: 89389		31.55	
JORSON & CARLSON CO	89390	12/31/2025	0765010	731-1022-541.29-04	84.00	GRANULATOR KNIVES
			Total for check: 89390		84.00	
JT ENGINEERING INC	89391	12/31/2025	250126-4	470-0703-553.80-05	11,970.86	HIGH CLIFF CONNECT DESIGNPR-2027-005
			Total for check: 89391		11,970.86	

AP Check Register

Check Date: 12/31/2025

Vendor Name	Check Number	Check Date	Invoice Number	Account Number	Amount	Description
JX ENTERPRISES INC	89392	12/31/2025	24135909P	731-1022-541.38-03	31.99	PRESSURE SWITCH
			Total for check: 89392		31.99	
KERRY'S VROOM SERVICE INC	89393	12/31/2025	10637	731-1022-541.38-04	124.69	VEHICLE REPAIR
			Total for check: 89393		124.69	
KLINK HYDRAULICS LLC	89394	12/31/2025	TV1610	731-1022-541.38-03	19.50	HOSE PROTECTOR (2
			Total for check: 89394		19.50	
MATTHEWS TIRE INC	89395	12/31/2025	100120	731-1022-541.38-02	2,082.32	TIRES/REPAIR
		12/31/2025	100136	731-1022-541.38-02	736.80	TIRES
		12/31/2025	100178	731-1022-541.38-04	649.44	TIRES
			Total for check: 89395		3,468.56	
MENASHA TREASURER	89396	12/31/2025	PETTY CASH	100-0702-552.30-18	50.00	BALL IT BALLS EME PROGRAMPAY BACK JACILYN'S DRAW
			Total for check: 89396		50.00	
MENASHA TREASURER	89397	12/31/2025	TAXES-262 WATER	100-0000-441.16-00	5.00	RECYCLE CART CHARGE 262 WATER ST
			Total for check: 89397		5.00	
MENASHA TREASURER	89398	12/31/2025	TAXES-325 BROAD	501-0000-191.00-00	3,517.67	PROPERTY TAXES-325 BROAD
				501-0304-562.74-01	3,216.40	PROPERTY TAXES-325 BROAD
			Total for check: 89398		6,734.07	
MENASHA UTILITIES	89399	12/31/2025	DELINQUENT UTIL	100-0000-201.03-00	179.68	DELINQUENT UTILITIES -654 DEPERE ST
		12/31/2025	MENASHA UTIL.	100-0305-562.22-05	50.04	10/29/25-11/26/25-WAT/SEW
				100-0305-562.22-06	16.72	10/29/25-11/26/25-STORM
				100-0601-551.22-07	63.23	10/29/25-11/26/25-LIBRARY-DARK FIBER
				100-0703-553.22-05	349.57	10/29/25-11/26/25-WAT/SEW
				100-0703-553.22-06	126.46	10/29/25-11/26/25-STORM

AP Check Register

Check Date: 12/31/2025

Vendor Name	Check Number	Check Date	Invoice Number	Account Number	Amount	Description
MENASHA UTILITIES...	89399...	12/31/2025...	MENASHA UTIL....	100-0704-552.22-07	446.36	10/29/25-11/26/25-POOL -DARK FIBER
				100-1012-541.22-03	85.43	10/29/25-11/26/25-ELEC
				100-1013-541.22-03	12.36	10/29/25-11/26/25-ELEC
				100-1013-541.22-05	45.57	10/29/25-11/26/25-WAT/SEW
				100-1013-541.22-06	246.63	10/29/25-11/26/25-STORM
				100-1014-543.22-05	16.68	10/29/25-11/26/25-WAT/SEW
				100-1014-543.22-06	80.47	10/29/25-11/26/25-STORM
				100-1019-552.22-05	45.59	10/29/25-11/26/25-WAT/SEW
				100-1019-552.22-07	196.21	10/29/25-11/26/25 -DARK FIBER
				207-0707-552.22-07	57.44	10/29/25-11/26/25-MARINA -DARK FIBER
				487-0305-562.22-06	14.63	10/29/25-11/26/25-STORM
				501-0304-562.22-06	235.13	10/29/25-11/26/25-STORM
				731-1022-541.22-07	595.45	10/29/25-11/26/25-GARAGE -DARK FIBER
				743-0403-513.21-04	165.69	10/29/25-11/26/25-IT -INTERNET
				743-0403-513.22-07	504.59	10/29/25-11/26/25-IT -DARK FIBER
				Total for check: 89399		
METRO SALES INC	89400	12/31/2025	INV2967473	743-0403-513.29-01	1,011.64	PRINTER/COPIER USAGE 11/17-12/16
				Total for check: 89400		
N&M AUTO SUPPLY	89401	12/31/2025	851967	731-1022-541.38-04	21.76	LAMP
				851993	15.98	SILICON
				852161	18.00	AIR FILTER
				Total for check: 89401		
NEENAH, TOWN OF	89402	12/31/2025	010 0223	100-0701-533.22-06	60.00	CEMETERY STORMWATER CHG
				Total for check: 89402		
CITY OF NEENAH	89403	12/31/2025	40246	255-0501-522.30-15	1,439.30	RODRIGUEZ GEAR
					709.56	TURN OUT BOOTS
				470-0501-522.30-15	224.02	SCBA HARNESS CASES
				Total for check: 89403		

AP Check Register

Check Date: 12/31/2025

Vendor Name	Check Number	Check Date	Invoice Number	Account Number	Amount	Description
CITY OF NEENAH...	89403...	12/31/2025...	40246...	470-0501-522.30-15...	103.87	SENSIT DETECTORS
				470-0501-522.80-03	194.01	F200 GRAPHICS
				Total for check: 89403		5,766.39
NORTH STAR ENVIRONMENTAL TESTING	89404	12/31/2025	250-1830	470-0703-553.80-05	3,302.00	ASBESTOS INSPECTION PO-2026-001
						Total for check: 89404
PACKER CITY INTL TRUCKS INC	89405	12/31/2025	X103159638:03	731-1022-541.38-03	24.92	AIR FILTER, OIL FILTER
			X103159638:04	731-1022-541.38-03	20.77	AIR FILTER, OIL FILTER
			X103159638:05	731-1022-541.38-03	160.82	AIR FILTER, OIL FILTER
			X103160007:01	731-1022-541.38-03	91.12	OIL FILTER, FUEL FILTER
			X103160047:01	731-1022-541.38-03	62.10	FUEL/WATER SEPERATOR
			X103160151:01	731-1022-541.38-03	381.72	BRAKE CHAMBER
			X103160154:01	731-1022-541.38-03	383.60	AIR FILTER, OIL FILTER, FUEL FILTER/SEPERATOR
			X103160159:01	731-1022-541.38-03	234.38	BRAKE CHAMBER
			X103160159:02	731-1022-541.38-03	117.19	BRAKE CHAMBER
			X103160189:01	731-1022-541.38-03	37.64	AIR FILTER, OIL FILTER
			Total for check: 89405		1,514.26	
PRIME MEDIA ACQUISITION CORP	89406	12/31/2025	0262752-IN	100-0801-521.29-01	159.12	TRACS PAPER FOR SQUADS
						Total for check: 89406
PSYCHOLOGIE CLINIQUE SC	89407	12/31/2025	MENASHA PD	100-0801-521.21-05	650.00	PSYCH EVAL
					650.00	PSYCH EVAL
					Total for check: 89407	
STRAND ASSOCIATES INC	89408	12/31/2025	0233162	470-0703-553.80-05	1,553.22	PROFESSIONAL SERVICES-NOVPR-2025-011 JEFF PRK BC
						Total for check: 89408
THEDACARE AT WORK	89409	12/31/2025	377913	100-0202-512.21-05	255.00	EMPLOYEE SCREENING

AP Check Register
Check Date: 12/31/2025

<i>Vendor Name</i>	<i>Check Number</i>	<i>Check Date</i>	<i>Invoice Number</i>	<i>Account Number</i>	<i>Amount</i>	<i>Description</i>
THEDACARE AT WORK...	89409...	12/31/2025	377987	100-0202-512.21-05	255.00	EMPLOYEE SCREENING
			Total for check: 89409		510.00	
TRUCK EQUIPMENT INC	89410	12/31/2025	1177060-00	731-1022-541.38-03	110.18	RELAY, JUNCTION BOX
			Total for check: 89410		110.18	
WASTEQUIP LLC	89411	12/31/2025	4161204	731-1022-541.38-03	322.88	WEAR PAD, SCRAPER
			Total for check: 89411		322.88	
YOUNG INNOVATIONS	89412	12/31/2025	CD61183030	100-0916-531.30-18	393.96	VARNISH
			Total for check: 89412		393.96	
					116,305.10	



MEMORANDUM

DATE December 30, 2025
TO Honorable Mayor and Common Council
FROM Andrew Dane, Community Development Director
RE Professional Service Agreement between the City of Menasha and RG Inspections for Commercial Electric Inspection Services AND Increase of the Minimum Commercial Electric Inspection Fee

Background

On December 15th, 2025, staff recommended and the Administration Committee approved the professional service agreement between the City of Menasha and RG Inspections to provide Commercial Electric Inspection Services. Staff also recommended the Administration Committee approved an increase in the minimum commercial electric permit fee from \$50.00 to \$250.00

Following these two actions the City of Menasha received communication from a professional commercial electrician expressing desire to provide commercial electrical inspection services for the City of Menasha as a part time casual employee. This arrangement is more favorable to the City of Menasha because it allows the City to provide a higher level of service at a lower cost.

Recommendation

Staff recommend the Common Council take no action to approve the professional service agreement between the City of Menasha and RG Inspections to provide Commercial Electric Inspection Services. Staff also recommend that Common Council take no action to approve the increase of the minimum commercial electric permit fee from \$50.00 to \$250.00



RESOLUTION R-32-25

A RESOLUTION INCREASING THE COMMERCIAL ELECTRICAL PERMIT
INSPECTION FEES FOR THE CITY OF MENASHA
INTRODUCED BY: Mayor Hammond

WHEREAS, the City of Menasha (the “City”) performs permit inspection services as one of its governmental functions; and

WHEREAS, the City has obtained Delegated Municipal or Appointed Agent Status from the State of Wisconsin for Commercial Electrical Permit Inspections, as required; and

WHEREAS, the City does not believe that the amount of commercial electrical permit inspection services justifies the hiring of a part-time or full-time employee, and has instead sought RG Inspections, LLC (“RG”), to perform these commercial electrical inspection services for and on behalf of the City; and,

WHEREAS, the current commercial electrical permit inspection fee for New Building, Additions, and Alterations is \$50 + .055 per sq ft all areas with a \$50 Minimum; and

WHEREAS, the City has determined that the commercial electrical permit inspection fee for New Building, Additions, and Alterations needs to be increased to \$10 per thousand the value of the electrical project with a \$250 Minimum in order to enter into a Professional Services Agreement (PSA) with RG for RG to provide such services within the City; and

WHEREAS, the current commercial electrical permit inspection fee for Replacement & Misc. Items is \$10 per thousand the value of the electrical project with a \$50 Minimum; and

WHEREAS, the City has determined that the commercial electrical permit inspection fee for Replacement & Misc. Items needs to be increased to \$250 Minimum, in order to enter into a Professional Services Agreement (PSA) with RG for RG to provide such services within the City; and

WHEREAS, the City finds increasing the commercial electrical fees as described above does not exceed the City’s reasonable direct costs that are associated with any activity undertaken by the City that is related to the fee, pursuant to section 66.028 of the Wisconsin Statutes.

NOW, THEREFORE, BE IT RESOLVED by the Common Council of the City of Menasha that:

The commercial electric inspection fee for New Building, Additions, and Alterations is increased to \$10 per thousand the value of the electrical project with a \$250 Minimum, and the commercial electrical permit inspection fee for Replacement & Misc. Items is increased to \$250 Minimum, effective January 6, 2026.

Adopted this ____ day of January, 2026.

Recommended by: _____
Motion/Second: _____
Pass/Fail: _____
Requires: <input checked="" type="checkbox"/> Majority Vote <input type="checkbox"/> 2/3 Vote

Austin R. Hammond, Mayor

ATTEST:

Kaija Snyder, City Clerk

Residential Fee Schedule

Effective August 5, 2024

Building

New one/two Family Dwelling and Additions	\$0.14 per SF all areas (for each unit) \$75 minimum
Erosion Control	\$75
Remodel, Alteration & Other	\$0.10 per SF (\$50 minimum) If SF can't be calc b/c/ of project (example siding) then, \$35 + \$5 per \$1,000 the cost of project (\$50 minimum)
Accessory Structure (sheds, decks, detached garages, and similar)	\$0.12 per sq ft all areas (\$40 minimum)
Pools (permanent & temporary)	\$50 (includes electric)
Early Start Permit	\$50 (footings and foundations only)
Razing Fee	\$50 for the 1st 1,000 sq. ft. of floor area & \$25 per 1,000 sq. ft. of floor area thereafter
Occupancy Permit	\$50 (Per dwelling unit)
Temporary Occupancy Permit	\$50 (Per dwelling unit)
State Seal	\$33

HVAC

New One/Two Family Dwelling Additions, Alterations	\$40 + .03 per sq ft all areas (\$40 Minimum for each unit)
Replacement & Misc. Items	\$10 per thousand the value of the HVAC project \$40 Minimum

Electrical

New One/Two Family Dwelling Additions, Alterations	\$40 + .04 per SF all areas \$40 Minimum for each unit
Replacement & Misc. Items	\$10 per thousand the value of the electrical project \$40 Minimum

Plumbing

New One/Two Family Dwelling Additions, Alterations	\$40 + .04 per sq ft all areas (\$40 Minimum for each unit)
Replacement & Misc. Items	\$10 per thousand the value of the plumbing project \$40 Minimum

Miscellaneous

New HVAC License	\$45
HVAC License Renewal	\$30
Re-inspection Fee	\$35 Each (at inspector's discretion, example repeat offenders)
Failure to call for inspection	\$35 Each

Zoning

New Construction	\$65
Addition	\$50
Accessory Structures	\$30

Commercial Fee Schedule

Effective January 6, 2026

Building	
New buildings and alterations	\$0.15 per SF - \$150 minimum
Erosion Control	See Engineering Department
Remodel	\$9 per thousand the value of the project \$75 minimum
Early Start Permit	\$100 (footings and foundations only)
Razing Fee	\$100 for the 1st 1,000 sq. ft. of floor area & \$50 per 1,000 sq. ft. of floor area thereafter
Occupancy (Permanent & Temporary)	\$100 each unit
Reroof/re-siding	\$8 per thousand the value of the project \$75 Minimum
Other	\$8 per thousand the value of the project \$75 Minimum
HVAC	
New Building, Additions, Alterations (Alterations base on sq. ft. of alteration area)	\$50 + .055 per sq ft all areas \$50 Minimum
Replacement & Misc. Items	\$10 per thousand the value of the HVAC project \$50 Minimum
Electrical	
New Building, Additions, Alterations (Alterations base on sq. ft. of alteration area)	\$10 per thousand the value of the electrical project \$250 Minimum
Replacement & Misc. Items	\$10 per thousand the value of the electrical project \$250 Minimum
Plumbing	
New Building, Additions, Alterations	\$10 per fixture \$250 Minimum
Replacement & Misc. Items	\$10 per thousand the value of the plumbing project \$250 Minimum
Agricultural Building	
New Buildings	\$.04 per sq. ft. all floor areas
Remodel	\$5 per thousand of the value of the project \$40 Minimum
Other	\$40 Minimum
Commercial Zoning See Zoning Fee Schedule Sheet	

MEMORANDUM

DATE December 5, 2025
TO Board of Public Works
FROM James Merten, Director of Public Works
RE Ordinance O-14-25 – An Ordinance Amending Title 10, Chapter 1, Article C, Sections 10-1-25(7) and 10-1-27(4) of the Code of Ordinances, to Impose a “No Parking” Regulation on Broad Street

Staff received a request to establish a “no parking” zone on the south side of Broad Street, adjacent to the intersection with Racine Street. Parked vehicles reportedly create a heightened hazardous situation for guests and residents of the Headwaters Condominiums, particularly those accessing driveways. Staff support this request for the following reasons:

- **Traffic volume:** Broad Street functions as a primary east-west corridor immediately north of the Fox River and provides direct access between Downtown Menasha and Jefferson Park. Antidotally, it carries substantially more traffic than typical residential streets.
- **Access to major roadways:** It is a common practice for municipalities to prohibit parking on side-street approaches to higher-volume roadways. Such restrictions improve sight lines, maneuverability, and overall safety. The proposed “No Parking” zone aligns with this practice.
- **Visibility constraints:** While vehicles parked on-street commonly obstruct drivers’ ability to see oncoming traffic when exiting a driveway, the visibility constraints with the condominium driveways are exacerbated by the proximity of Racine Street and the grade difference with underground parking garage driveways.
- **Parking enforcement:** Terrace areas between the condominium driveways create the appearance of legal parking spaces. In practice, most standard-size vehicles cannot park there without encroaching within the statutory distance of the driveways. A posted “No Parking” restriction would eliminate confusion, deter illegal parking, and simplify enforcement.

Currently the posted parking restrictions in this area are as follows:

- **2-hour parking 9 AM to 5 PM on weekdays except holidays** on the south side of the street from roughly 205 feet (188 feet per code) east of Racine Street to Appleton Street.

- **No parking** on the north side of the street from Racine Street to 115 feet (140 feet per code) eastward therefrom.
- **15-minute parking** on the north side of the street from 115 feet east of Racine Street to 185 feet east of Racine Street. This 70-foot regulation is not reflected in the municipal code.

Proposed Ordinance O-14-25 would establish a “no parking” zone between Racine Street and the east property line of Headwaters Condominiums (511–515 Broad Street) and adjust the adjacent existing 2-hour parking zone accordingly. As noted above, the 15-minute parking zone is not reflected in the municipal code and should either be codified or removed. To offset the proposed “no parking” restriction, staff recommends that the 15-minute parking zone on the north side of Broad Street be removed.

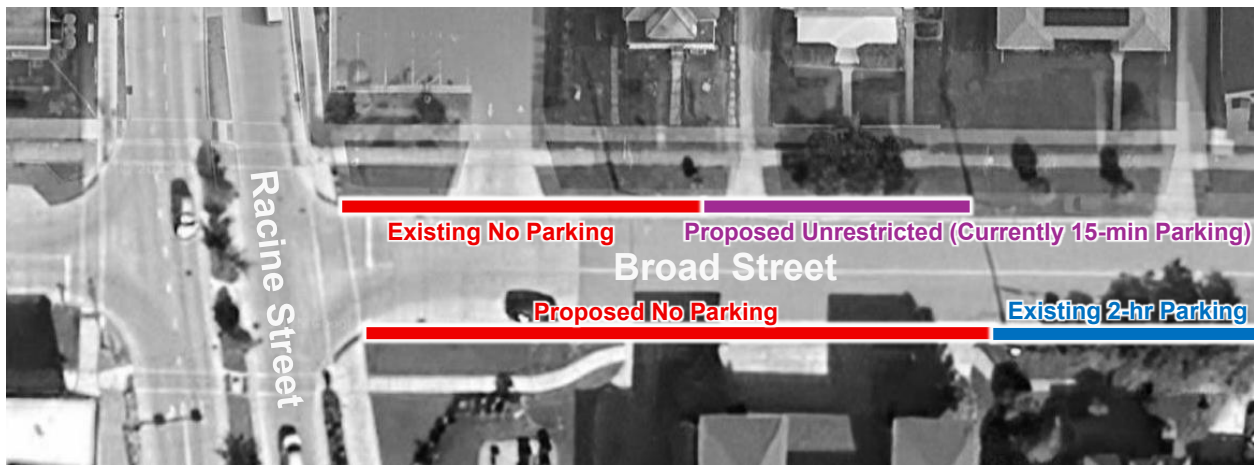

Staff recommends approving Ordinance O-14-25, amending Title 10, Chapter 1, Article C, Sections 10-1-25(7) and 10-1-27(4) of the Code of Ordinances, to impose a “no parking” regulation on Broad Street.

Attachments:

- Ordinance O-14-25 Draft
- Resident/Property Owner Notification Letter



ORDINANCE O-14-25

AN ORDINANCE AMENDING TITLE 10, CHAPTER 1, ARTICLE C, SECTIONS 10-1-26(7) AND 10-1-27(4) OF THE CODE OF ORDINANCES, TO IMPOSE A NO PARKING REGULATION ON BROAD STREET

INTRODUCED BY: Alderman Eisenach

The Common Council of the City of Menasha does hereby ordain as follows:

SECTION 1: Amend Title 10, Chapter 1, Article C, Section 10-1-26(7) of the Code of Ordinances of the City of Menasha, Wisconsin to add subsection (c), as follows:

**Title 10 – Motor Vehicles & Traffic
Chapter 1 – Traffic & Parking
Article C – Parking Regulations**

...

SEC. 10-1-26 NO PARKING.

...

(7) Broad Street:

- (a) The north side of Broad Street from Racine Street to one hundred forty (140) feet eastward therefrom.
- (b) The south side from the west terminus to seventy (70) feet eastward therefrom.
- (c) The south side from Racine Street to two hundred twenty (220) feet eastward therefrom.

...

SECTION 2: Amend Title 10, Chapter 1, Article C, Section 10-1-27(4) of the Code of Ordinances of the City of Menasha, Wisconsin as follows:

**Title 10 – Motor Vehicles & Traffic
Chapter 1 – Traffic & Parking
Article C – Parking Regulations**

...

SEC. 10-1-27 TIME RESTRICTED PARKING.

...

- (4) The south side of Broad Street from ~~one hundred eighty-eight (188)~~ two hundred twenty (220) feet east of Racine Street to Appleton Street.

...

SECTION 3: This amending Ordinance shall take effect upon passage and publication as provided by law.

Passed and approved this ___ day of ___ 2025.

Recommended by: _____
Motion/Second: _____
Pass/Fail: _____
Requires: __ Majority Vote __ 2/3 Vote

Austin Hammond, Mayor

ATTEST:

Kaija Snyder, City Clerk

December 5, 2025

RE: Notice of Proposed Parking Changes – Ordinance O-14-25

Dear Broad Street Resident and/or Property Owner,

The City of Menasha will be considering Ordinance O-14-25, which proposes the following parking regulation changes on Broad Street:

- Establishing a new **no parking zone** on the south side of Broad Street from Racine Street to the east property line of Headwaters Condominiums (511–515 Broad Street).
- Removing the existing **15-minute parking zone** in front of 514 Broad Street.



These changes are in response to a citizen request citing traffic safety and driver visibility concerns. Deliberation of the ordinance will take place at the following public meetings:

Board of Public Works

Monday, December 15, 2025 at 6:45 PM
Menasha City Center – First Floor Conference Room
100 Main Street, Menasha, WI 54952

Common Council *(if recommended by the Board of Public Works)*

Monday, January 5, 2026 at 6:00 PM
Menasha City Center – First Floor Conference Room
100 Main Street, Menasha, WI 54952

Agendas, staff reports, and meeting minutes will be made available at www.menashawi.gov under “Meeting Minutes & Agendas.” Residents are welcome to attend and provide feedback.

If you are unable to attend, but would like to comment, please feel free to contact me directly by email at jmerten@menashawi.gov or by phone at **(920) 967-3611**. All comments received will be forwarded to the Board members for their consideration.

Thank you for your attention to this matter. Your feedback is important to us.

Best regards,



James Merten
Public Works Director
City of Menasha Department of Public Works

CC: Menasha Board of Public Works, Mayor Hammond, Police Chief Thorn

MEMORANDUM

DATE December 9, 2025
TO Board of Public Works
FROM James Merten, Director of Public Works
RE Ordinance O-16-25 – An Ordinance Amending Title 10, Chapter 1, Article C, Sections 10-1-26(49) through 10-1-26(59) of the Code of Ordinances, to Impose a “No Parking” Regulation on Second Street

Staff received a request from Essity Professional Hygiene North America LLC (Essity), located at 190 Third Street, to establish a “no parking” zone on the north side of Second Street between Tayco Street and the western terminus (the semi-truck entrance to the Essity facility). This segment of Second Street is roughly 130 feet long, ends at the railroad tracks, and is bordered by Clinton Center Park on the south side and an undeveloped parcel owned by Essity on the north side.



The request is driven by safety concerns related to conflicts between parked vehicles, pedestrian traffic to and from the park, and semi-truck traffic entering the Essity facility.

Parks & Recreation Director Sackett has confirmed that existing street parking on the south side of Second Street is sufficient to accommodate current park usage. The proposed parking restriction would primarily affect Essity vehicle movements and Clinton Center Park visitors, with no significant impact on other properties or users.

Accordingly, staff recommends approving Ordinance O-16-25, amending Title 10, Chapter 1, Article C, Sections 10-1-26(49) through 10-1-26(59) of the Code of Ordinances, to impose a “no parking” regulation on the south side of Second Street. (See *attached ordinance draft.*)



ORDINANCE O-16-25

AN ORDINANCE AMENDING TITLE 10, CHAPTER 1, ARTICLE C, SECTIONS 10-1-26(49) THROUGH 10-1-26(59) OF THE CODE OF ORDINANCES, TO IMPOSE A NO PARKING REGULATION ON SECOND STREET

INTRODUCED BY: Alderman Ropella

The Common Council of the City of Menasha does hereby ordain as follows:

SECTION 1: Amend Title 10, Chapter 1, Article C, Sections 10-1-26(49) through 10-1-26(59) of the Code of Ordinances of the City of Menasha, Wisconsin, to insert a parking regulation on Second Street and renumber subsequent sections, as follows:

**Title 10 – Motor Vehicles & Traffic
Chapter 1 – Traffic & Parking
Article C – Parking Regulations**

...

SEC. 10-1-26 NO PARKING.

...

(49) *Second Street: The north side from the west terminus to Racine Street.*

~~(49)~~ (50) Seventh Street:

- (a) The north side from Appleton Road to two hundred thirty-five (235) feet westward therefrom (from April 1 through October 31).
- (b) The north side from Racine Street to one hundred seventy-five (175) feet eastward therefrom.
- (c) The south side from Racine Street to one hundred sixty-five (165) feet eastward therefrom.
- (d) The south side from Milwaukee Street to four hundred (400) feet westward therefrom (7:30 a.m. to 3:30 p.m., Monday through Friday).
- (e) The north side from Milwaukee Street to Kinzie Court (7:30 a.m. to 3:30 p.m., Monday through Friday).
- (f) The south side from Milwaukee Street to forty-nine (49) feet eastward therefrom.

- (g) The south side from School Court to thirty (30) feet westward therefrom.
- (h) The south side from School Court to seventy-two (72) feet eastward therefrom.
- (i) The north side from Milwaukee Street to forty-two (42) feet eastward therefrom.
- ~~(50)~~(51) Sheboygan Street: The north side from Manitowoc Street to seventy-five (75) feet eastward therefrom.
- ~~(51)~~(52) Sixth Street:
 - (a) The north side from Racine Street to Appleton Street.
 - (b) The north side from Milwaukee Street to eighty (80) feet westward therefrom.
- ~~(52)~~(53) Tayco Street:
 - (a) The east side from Main Street to two hundred (210) feet northward therefrom.
 - (b) The west side from Main Street to fifty (50) feet northward therefrom.
 - (c) Both sides from River Street to Main Street.
 - (d) The west side of Tayco Street from Third Street to Fourth Street.
- ~~(53)~~(54) Third Street:
 - (a) The north side from Milwaukee Street to Manitowoc Street.
 - (b) The north side from Tayco Street to two hundred fifty (250) feet eastward therefrom.
 - (c) The south side from one hundred (100) feet east of Manitowoc Street to Tayco Street.
- ~~(54)~~(55) University Drive: The east side.
- ~~(55)~~(56) Walnut Street: The west side from Ahnaip Street to Nicolet Boulevard.
- ~~(56)~~(57) Washington Street: Both sides except for the dedicated parking bay in front of 160 Washington Street.
- ~~(57)~~(58) Water Street:
 - (a) The north side from Lush Street to four hundred eighty (480) feet westward therefrom.
 - (b) The south side from Barlow Street to two hundred sixty (260) feet east of Barlow Street.
 - (c) The south side from three hundred seventy (370) feet west of Lush Street to eighty-five (85) feet east of Lush Street.
 - (d) The south side from three hundred fifty (350) feet east of Lush Street to the terminus.
- ~~(58)~~(59) Willow Lane: The east side from Nicolet Boulevard to Lake Road.
- ~~(59)~~(60) Winnebago Avenue: The east side from Nicolet Boulevard to Keyes Street.

SECTION 2: This amending Ordinance shall take effect upon passage and publication as provided by law.

Passed and approved this ___ day of ___ 2025.

Recommended by:

Motion/Second:

Pass/Fail: _____

Requires: __ Majority Vote
 __ 2/3 Vote

Austin Hammond, Mayor

ATTEST:

Kaija Snyder, City Clerk



Memorandum

To: Members of the Common Council

From: Chief Nick Thorn

Re: R-02-26- Resolution for participation in the statewide public safety interoperable communications system for Winnebago County and the City of Menasha

The WISCOM radio system will be undergoing a transition from the VHF communications to the 7/800 MHz communication platform. The WISCOM system is used by first responders to communicate across different radio programming platforms during major incidents or inter-agency operations. This transition requires agencies to reprogram and update firmware on their radios to be able to access the WISCOM 7/800 MHz communication platform. Our agency would not be able to use the WISCOM system without these updates.

The Wisconsin Department of Military Affairs is offering \$3 million in grant funds to agencies for these upgrades. Each agency is allowed a maximum of \$50,000 to offset the costs of this upgrade. This grant requires a 20% local match. Our total project cost to update and reprogram our existing radios is \$47,826.70. This includes all portable and mobile radios. The City of Menasha's 20% match is \$9,565.34. If we are not awarded this grant, funding for this project has already been requested in the 2027 budget. Our current plan is to reduce the number of portable radios we will replace this year, so the 20% match is covered by that line item in the budget. It is anticipated that the Police Department will only need to reduce our purchase by 1 radio to make up the difference needed to cover the 20% match. This will result in a zero net effect on the Police Departments 2026 budget. The grant application requires resolution approval by the governing body supporting the 20% fund match.

The Police Department is recommending the Common Council approve this resolution so we may submit a grant application prior to the January 15th, 2026 deadline.



RESOLUTION R-2-26

INTENTION TO JOIN THE STATEWIDE PUBLIC SAFETY INTEROPERABLE COMMUNICATION SYSTEM FOR WINNEBAGO COUNTY AND THE CITY OF MENASHA

INTRODUCED BY: Mayor Hammond

WHEREAS, Wisconsin Statute § 323.29(5) requires the Wisconsin Department of Military Affairs to provide grants to local units of government for public safety interoperable communication system upgrades.

WHEREAS, the Wisconsin Department of Military Affairs refers to the statewide public safety interoperable communication system as WISCOM, and the upgraded 7/800 MHz system as WISCOM 800.

WHEREAS, Wisconsin Statute § 323.29(5)(b)2 requires that, to be eligible for a grant, the local unit of government's governing body submit a resolution or other written commitment indicating its intent to join the replacement statewide public safety interoperable communication system when it becomes available.

WHEREAS, Wisconsin Statute § 323.29(5)(b)2 requires that, to be eligible for a grant, the local unit of government's governing body submit a resolution or other written commitment indicating the local unit of government's intent to spend its own funds in an amount equal to 20 percent of the total grant awarded.

NOW, THEREFORE, BE IT RESOLVED by Menasha Common Council, that the Menasha Police Department is hereby committed to joining the replacement statewide public safety interoperable communication system as a daily user when it becomes available and will spend its own funds for 20 percent of the total of any grant awarded.

Passed and approved this ____ day of _____, 2026.

Recommended by:

Motion/Second:

Pass/Fail: _____

Requires: _____ Majority Vote
_____ 2/3 Vote

Austin R. Hammond, Mayor

ATTEST:

Kaija Snyder, City Clerk



MEMORANDUM

To: Common Council

From: Director of Parks & Recreation – Megan Sackett/ms

Date: December 29, 2025

RE: R-1-26 Reauthorization of State Funding for the Knowles-Nelson Stewardship Program

The Knowles-Nelson Stewardship Program is a statewide grant program that has supported Wisconsin communities since 1989 by funding park improvements, trail development, land conservation, and expanded public access to outdoor recreation. Its matching grant structure allows municipalities to leverage local dollars and complete projects that might otherwise be unaffordable. The program is authorized only through June 2026, and funding has been reduced in recent years, limiting the number of projects it can support. Reauthorizing and restoring funding would provide long-term stability for communities planning multi-year park, trail, and conservation projects.

Supporting reauthorization aligns with the City of Menasha's commitment to maintaining high quality parks, preserving natural areas, and meeting growing demand for outdoor recreation opportunities. This resolution affirms the City's support for continued investment in the Stewardship Program.

Recommendation

Park Board recommends to the Common Council approval of R-1-26 for the Reauthorization of State Funding for the Knowles-Nelson Stewardship Program.



RESOLUTION NO. R-1-26

REAUTHORIZATION OF STATE FUNDING FOR THE KNOWLES-NELSON STEWARDSHIP PROGRAM.

Introduced by Alderperson Ted Grade and Mayor Austin Hammond

WHEREAS, the Knowles-Nelson Stewardship Program has been a cornerstone of Wisconsin's outdoor heritage for more than three decades-uniting lawmakers, local governments, land trusts, and residents around shared goals of protecting natural lands, improving water quality and expanding outdoor recreation opportunities for all; and

WHEREAS, the Wisconsin Legislature created the Knowles-Nelson Stewardship Program in 1989 (s. 23.09 15 (2c)(d), Wis. Stats) to preserve valuable natural areas and wildlife habitat, protect water quality and fisheries, and expand opportunities for outdoor recreation; and

WHEREAS, the City of Menasha and its residents and visitors have experienced these benefits firsthand, with over \$2.0 Million in investments that include the Loop the Little Lake Trail, Heckrodt Wetland Reserve development, Gilbert Trail Development, Barker Farm Park – enhancing daily access to nature, recreation and healthy living across our community; and

WHEREAS, the Wisconsin Supreme Court's 2024 decision ending anonymous legislative veto authority brought needed transparency, but also introduced uncertainty around future funding approvals, resulting in the program being left out of the 2025-27 state budget; and

WHEREAS, the Knowles-Nelson Stewardship Program is scheduled to sunset on June 30, 2026, unless renewed by the Legislature, placing at risk the continued protection of natural lands, the expansion of the outdoor recreation opportunities, progress towards climate resilience and efforts to ensure clean and accessible waterways throughout Wisconsin; and

WHEREAS, the long-term reauthorization of the Knowles-Nelson Stewardship Program, with sufficient and stable funding, is essential for local governments to plan and complete future park, trail, and open space projects that support environmental sustainability, public health, economic vitality, and a high quality of life;

WHEREAS, it is the intent of the City of Menasha to express its support of the reauthorization of the Knowles-Nelson Stewardship Program in 2026 with sufficient funding allocated to fund projects over the next 10 years in a manner to be determined by the Legislature and the Governor;

NOW, THEREFORE, BE IT RESOLVED, the City of Menasha urges the Wisconsin State Legislature to act promptly and in bipartisan fashion to reauthorize and adequately fund the Knowles-Nelson Stewardship Program for a multi-year period that will provide stability and predictability for communities statewide; and

NOW THEREFORE, BE IT RESOLVED, that the City of Menasha affirms its strong support for continued and sufficient funding for local government grants within the program, ensuring that communities of all sizes have the tools necessary to conserve natural resources and maintain safe, accessible public lands for generations to come; and

BE IT FURTHER RESOLVED, that the City Clerk is hereby directed to forward a copy of this resolution to the offices of each of our local State Legislators including Representative Kaufert, Senator Dassler-Alfheim, Representative Tusler and Senator Jacque and the Office of the Governor.

Passed and approved this ____ day of January, 2026.

Recommended by:
Motion/Second:

Vote:
Pass/Fail:

Requires: Majority Vote

Austin R. Hammond, Mayor

ATTEST:

Kaija Snyder, City Clerk

Hello Austin and Megan,

I am writing to express my intent to be considered by the Common Council for a board position with the Menasha Parks and Recreation Department. With a deep appreciation for our community's outdoor spaces and recreational programs, I am eager to contribute my skills and experience to enhance the quality of life for residents in Menasha.

I have a strong background in community service and project management. My project management skills come from 8+ years working in the corporate world fulfilling roles at all levels of projects, from planning to execution and completion. My community service background has taken many forms throughout my life, from the Boy Scouts of America in my youth, to service for the country in the United States Marine Corp as a young adult, to more recently volunteering for Parent Teacher Organizations and Doty Island Community Partners events.

I believe that accessible, well-maintained parks and diverse recreational programs are vital for the well-being of our community. I have heard of a few of the upcoming projects planned for the Department and would love the opportunity to be able to see them accomplished. I am excited about the possibility of working collaboratively with the board and community members to address current challenges and develop new initiatives that promote active living.

Thank you for considering my application. I look forward to the opportunity to discuss how I can contribute to the Menasha Parks and Recreation Department and support its mission to enhance our community's recreational and environmental health.

Sincerely,

Tommy Webster